



Open-Mounted Adjustable Set Point Air Pressure Sensing Switch

APPLICATION

The model **AFS-303-112** is a general purpose proving switch with gold contacts designed for HVAC, Energy Management and DDC (Direct Digital Control) applications. Gold-contact switches are used in computer environments, direct digital control, or wherever low ampere currents are wired. **AFS-303-112** can be used to sense positive, negative, or differential air pressure. The **AFS-303-112** is equipped with convenient barbed sample line connectors that accept flexible tubing.

DESCRIPTION & OPERATION

The plated housing contains a diaphragm, a calibration spring and a snap-acting SPDT switch with **gold contacts**. The sample connectors located on each side of the diaphragm accept flexible tubing.

MOUNTING (FIG. 1)

Select a mounting location that is free from vibration. The **AFS-303-112** must be mounted with the diaphragm in any vertical plane in order to obtain the lowest specified operating set point. Avoid mounting with the sample line connections in the "up" position. Surface mount via the two 3/16" diameter

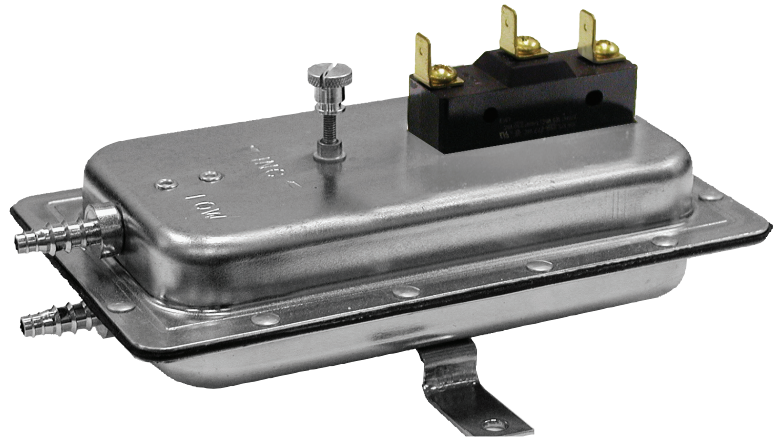

holes in the integral mounting bracket. The mounting holes are 3-7/8" apart.

AIR SAMPLING CONNECTION (FIG.2)

The **AFS-303-112** is designed to accept flexible tubing by means of the barbed sample connectors. Locate the sampling probe a minimum of 1.5 duct diameters downstream from the air source. Install the sampling probe as close to the center of the airstream as possible. Refer to **Figure 2** to identify the high pressure inlet (**H**) and the low pressure inlet (**L**). Select from the five application options listed below, and connect the sample lines as shown.

POSITIVE PRESSURE ONLY: Connect the sample line to inlet **H**; inlet **L** remains open to the atmosphere.

NEGATIVE PRESSURE ONLY: Connect the sample line to inlet **L**; inlet **H** remains open to the atmosphere.

TWO NEGATIVE SAMPLES: Connect the higher negative sample to inlet **L**. Connect the lower negative sample to inlet **H**.

TWO POSITIVE SAMPLES: Connect the higher positive sample to inlet **H**. Connect the lower positive sample to inlet **L**.

ONE POSITIVE & ONE NEGATIVE SAMPLE: Connect the positive sample to inlet **H**. Connect the negative sample to inlet **L**.

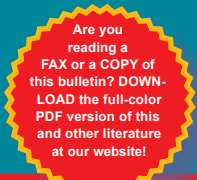
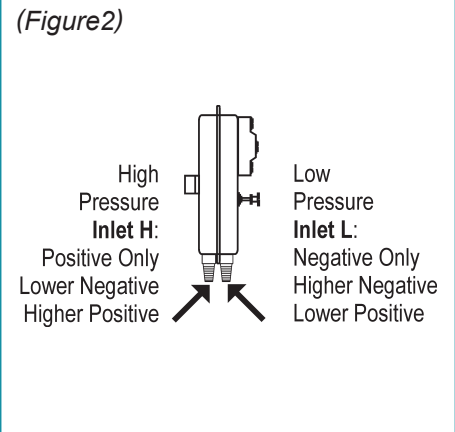
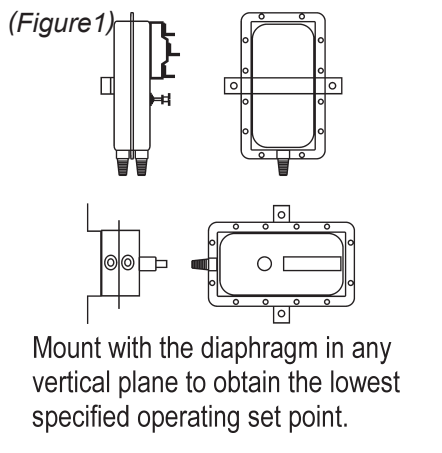

ELECTRICAL CONNECTIONS (FIG.3)

Before pressure is applied to the diaphragm, the switch contacts will be in the normally closed (NC) position. The snap switch has ¼" 90° quick connect spade terminals. Wire alarm and control applications as shown in Fig.4.

FIELD ADJUSTMENT

The adjustment range of an **AFS-303-112 Air Switch** is 0.05±0.02" w.c. to 12.0" w.c. To adjust the set point, turn the adjusting screw counterclockwise until motion has stopped. Next, turn the adjusting screw 4 complete turns in a clockwise direction to engage the spring. From this point, the next ten turns will be used for the actual calibration. **Each full turn represents approximately 1.2" w.c.**

Please note: To properly calibrate an air switch, a digital manometer or other measuring device should be used to confirm the actual set point.

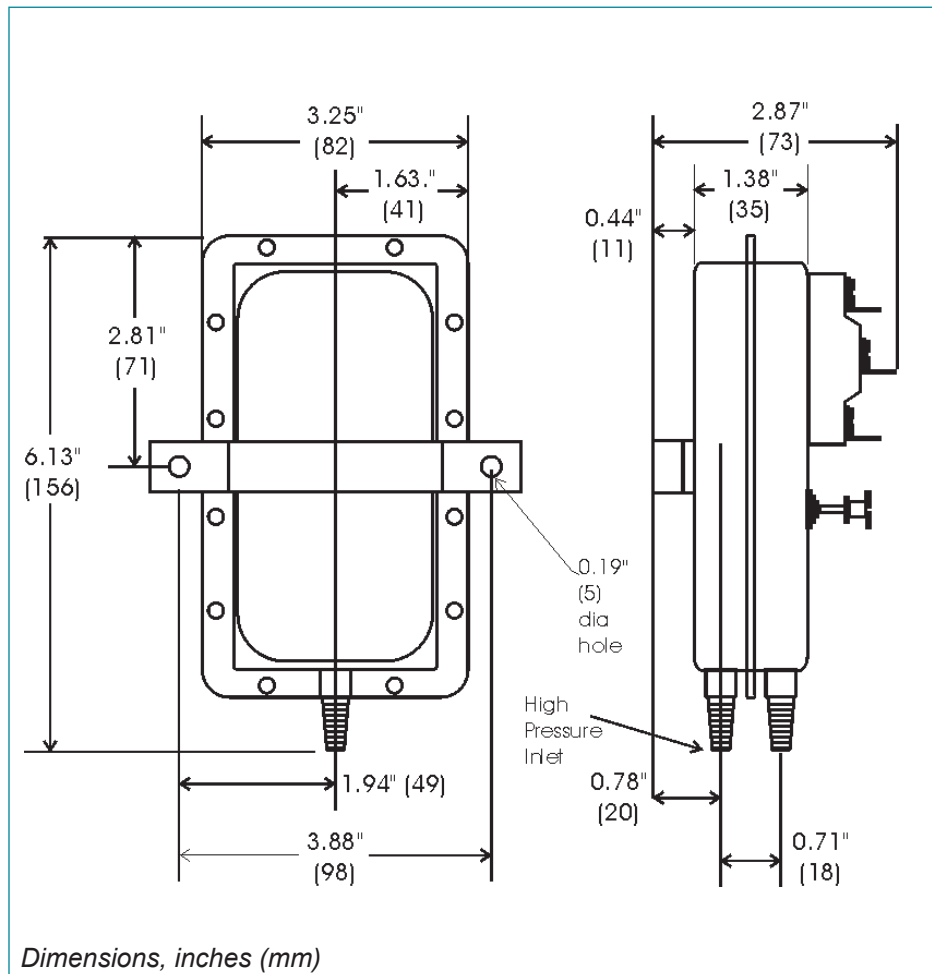
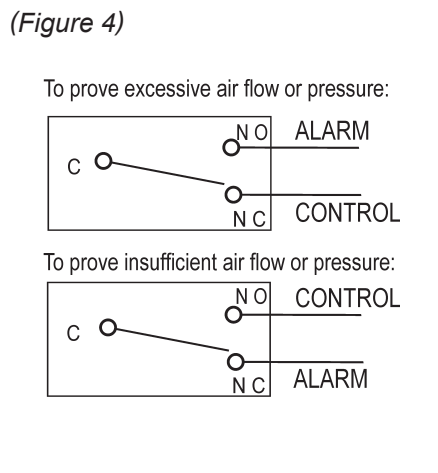
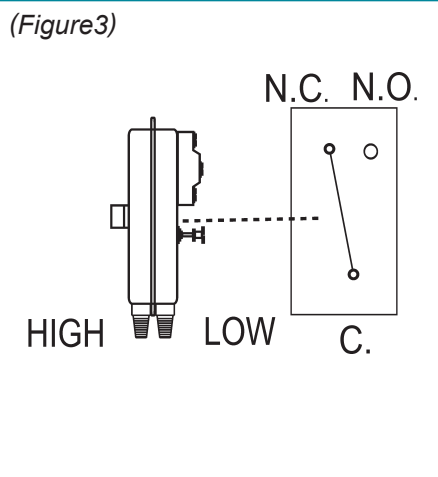

SPECIFICATIONS

MODEL AFS-303-112 AIR FLOW PRESSURE SENSING SWITCH WITH GOLD CONTACTS

Mounting Position: Mount with the diaphragm in any vertical plane.

Set Point Range: 0.05" ± 0.02" w.c. to 12.0" w.c.

Field Adjustable "Operate Range": 0.07" w.c. to 12.0" w.c.

Field Adjustable "Release Range": 0.04" w.c. to 11.2" w.c.

Approximate Switching Differential: Progressive, increasing from 0.02± 0.01" w.c. at minimum set point to approximately 0.8" w.c. at maximum set point.

Measured Media: Air, or combustion by-products that will not degrade silicone.

Maximum Pressure: ½ psi
(0.03 bar)

Operating Temperature Range:
-40F to 180F (-40 to 82C)

Life: 100,000 cycles minimum at ½ psi maximum pressure each cycle and at maximum rated electrical load.

Electrical Rating:

300 VA pilot duty at 115 to 277 VAC,
15 amps noninductive to 277 VAC,
10 ma at 5 VDC (applies to dry circuit applications).

Contact Arrangement: SPDT

Electrical Connections: Gold, ¼" 90° quick-connect spade terminals.

Sample Line Connectors: Two barbed ¼" connectors accept flexible tubing.

Approval: UL, CSA pending

Shipping Weight: 1.2 lbs.

Accessories

- Sample line probes.
- Orifice plugs (pulsation dampers).