



# Cleveland Controls

Division of UniControl Inc.

# Model AFS-953

ADJUSTABLE SET POINT AIR PRESSURE SENSING SWITCH WITH  
20-SECOND PRE-PURGE AND 8-SECOND TIME DELAY IN CHOICE OF NEMA-RATED ENCLOSURE



*AFS-953 in Standard Enclosure,  
rated NEMA-1.*



*AFS-953-1 in NEMA-4 rated  
Enclosure.*



*AFS-953-2 in NEMA-7 and  
NEMA-9 rated Enclosure.*

## DESCRIPTION & OPERATION

The **Cleveland Controls AFS-953 Differential Pressure Sensing Switch** is designed to provide precise operation and convenient features for industrial and commercial air handling applications. The **AFS-953** can monitor positive, negative, or differential pressure (flow) of air and noncombustible gases. It is commonly used to monitor combustion air, furnace pressure, ventilating blower operation, inflatable structure pressure, fume hood operation, bag house air flow, dirt accumulation in air filters, and heat-transfer air flow. The **AFS-953** has a field-adjustable set point range of 0.05"wc to 12.0"wc with a 20-second pre-purge delay and an 8-second ( $\pm 3$  seconds) time delay relay sequence. The time delay prevents nuisance shutdowns due to normal draft fluctuations.

## COMMON APPLICATIONS

The most common specific application for the **AFS-953** is as a **Low Draft (Negative Pressure) Cutoff Safety Switch** for combustion draft control systems where individual pre-purge is needed. In general, the **AFS-953** can be applied as follows:

- **Low Positive Pressure Cutoff.** (Shutdown upon insufficient pressure.)
- **Low Negative Pressure Cutoff.** (Shutdown upon insufficient draft.)
- **Low Differential Pressure Cutoff.** (Shutdown upon insufficient difference between two samples.)

## MOUNTING

Three NEMA-rated enclosures, designed for surface mounting on any flat, relatively stable surface free of vibration, are available for the **AFS-953**. The standard enclosure has mounting flanges with four mounting holes (9/32") as shown in drawing on page 3. The NEMA-4 rated model has mounting flanges with four 5/16" mounting holes as shown at top of page 4. The NEMA-7/NEMA-9 rated enclosure has two mounting slots as shown at bottom of page 4. With any of the enclosures, the **AFS-953 must be mounted with the diaphragm in a vertical plane, to obtain the lowest operating set point specification.**



**Cleveland Controls**  
DIVISION OF UNICONTROL INC.  
1111 Brookpark Rd  
Cleveland OH 44109

Tel: 216-398-0330

Fax: 216-398-8558

Email: [salesvac@unicontrolinc.com](mailto:salesvac@unicontrolinc.com)

Web page: <http://www.clevelandcontrols.com>

Are  
you reading  
a FAX or a COPY  
of this bulletin?  
DOWNLOAD the full-  
color PDF version  
of this and other  
literature at our  
website!

## PIPING

The field sample line connectors, two 1/4" - 18 NPT female fittings, labeled **H (high)** and **L (low)**, are located on the side of the enclosure as shown in Figure 1.

**Positive Pressure only:** Connect sample line to **H**; **L** remains open to the atmosphere.

**Negative Pressure only:** Connect sample line to **L**; **H** remains open to the atmosphere.

**Two Negative Samples:** Connect higher negative sample to **L**, lower negative sample to **H**.

**Two Positive Samples:** Connect higher positive sample to **H**, lower positive sample to **L**.

**One Negative and One Positive Sample:** Connect positive sample line to **H**, negative sample line to **L**.

For each right angle bend, add four feet to the computed line length in order to determine correct pipe or tubing size. If either sample line connector is vented to the atmosphere, attach an elbow to it so that the open end of the connector points downward. This will help protect the switch from contamination.

## ELECTRICAL CONNECTIONS

Five numbered terminals are provided for field wiring. Terminals are pressure clamp screw type.

## SEQUENCE OF OPERATION

Before pressure and power are applied to the **AFS-953**, the SPDT switch contacts are in the normally closed position as shown in **Figure 2** ("shelf" condition); relay contacts T-T (TD-1) and 3-4 (TD-2) are open. When the sample lines are connected as shown in **Figure 1**, and power is applied to terminals 1 and 2, the following sequence occurs.

The pre-purge period (20 seconds) commences: the red lamp is off. The TD1 time delay is energized. The 20-second timing sequence commences.

At the end of the 20-second timing sequence, T-T contacts close.

If, at the end of the 20-second timing sequence the switch is below set point, the SPDT contacts are in NC position, the red light comes on, the relay contacts 3 and 4 remain open, and T-T contacts remain closed. This condition is "alarm mode."

If, at the end of the 20-second timing sequence the switch is above set point, the SPDT contacts are in NO position, the red light does not come on, the TD2 time delay is energized and the 8-second timing cycle commences. Relay contacts 3 and 4 remain open during the 8-second cycle. After the 8-second cycle is completed, contacts 3 and 4 close. T-T contacts remain closed. This condition is "operating mode."

Whenever differential pressure drops below the set point, the SPDT switch contacts change to NC immediately, turning the red lamp on, and de-energizing the TD2 time delay, which starts the 8-second timing sequence. The relay contacts 3 and 4 remain closed unless the 8-second timing sequence is completed: differential pressure must remain below set point for 8 seconds continuously to complete the sequence. After this 8-second period, TD-2 relay contacts 3 and 4 open: the switch is in "alarm mode."

When the differential pressure becomes greater than set point, the SPDT switch contacts change to NO immediately, turning the red lamp off, and energizing the TD2 time delay. The differential pressure must remain greater than set point for 8 seconds continuously before the TD2 time delay closes contacts 3 and 4, returning the switch to normal "operating mode."

AFS-953 Contact Configurations	T - T (TD-1)	3 - 4 (TD-2)	Red Light
<b>1. On Shelf Contact Positions</b> before power is applied			
<b>Figure 2</b> shows <b>AFS-953</b> in "on shelf" condition: before power is applied to the circuit and before pressure is applied to diaphragm.	open	open	off
<b>2. Pre-purge Contact Positions</b>			
During initial 20-second period after power is applied: contacts TT stay open. (TD-1)			
Power Applied; Differential Pressure below Set Point (Immediate).	open	open	off
Power Applied; Differential Pressure above Set Point (Immediate)	open	open	off
During initial 20-second period after power is applied: contacts 3-4 also stay open., even after 8-seconds have elapsed (TD-2).			
Power Applied; Differential Pressure below Set Point (After 8 seconds).	open	open	off
Power Applied; Differential Pressure above Set Point (After 8 seconds).	open	open	off
<b>3. Purged Contact Positions</b>			
After 20 seconds with power applied contacts TT (TD-1) close, and remain closed unless power is interrupted.			
Differential Pressure below Set Point (Immediate).	<b>closed</b>	open	<b>on</b>
Differential Pressure above SetPoint (Immediate).	<b>closed</b>	open	off
After 8 seconds (a total of 28 seconds of uninterrupted operation), contacts 3-4 (TD-2) can change state.			
Differential Pressure below Set Point (after 8 seconds.)	closed	<b>open</b>	<b>on</b>
Differential Pressure above Set Point (after 8 seconds.)	closed	<b>closed</b>	off
Power interrupted.	Prepurge cycle repeats.		

## FIELD ADJUSTMENTS

For the standard NEMA-1 enclosure, field adjustments to the operating set point are made by removing the protective plug button on the side of the enclosure and inserting a standard blade-type screwdriver, at least 3 inches long. For the NEMA-4 and NEMA-7/9 enclosures, it is necessary to open the enclosure to make adjustments. The adjustment range is **0.05±.02" w.c. to 12.0" w.c.** To adjust the set point, turn the adjusting screw counterclockwise until motion has stopped. Next, turn the adjusting screw **4 complete turns** in a clockwise direction to engage the spring. For the **next 10 turns, each full turn represents approximately 1.2" w.c.** At higher operating pressures, there is a slight increase in the switching differential. **Please note:** To properly calibrate an air pressure sensing switch, a digital manometer or other measuring device should be used to confirm the actual set point.

## SPECIFICATIONS

### MODEL AFS-953 AIR PRESSURE SENSING SWITCH

#### Mounting Position:

Mount with the diaphragm in any vertical plane.

**Set Point Range:** 0.05 ± 0.02" w.c. to 12.0" w.c. (1.3 to 305 mm wc; 0 to 4.33 psi).

**Field Adjustable "Operate Range":** 0.07" w.c. to 12.0" w.c.

**Field Adjustable "Release Range":** 0.04" w.c. to 11.2" w.c.

#### Approximate Switching Differential:

Progressive, increasing from 0.02 ± 0.01" w.c. at minimum set point to approximately 0.8" w.c. at maximum set point. (0.5 ± .25 mm to approximately 20.3 mm).

**Operating Temperature Range:** 0F to 130F (-18 to 54.4C).

**Measured Media:** Air or combustion by-products that will not degrade silicone.

**Maximum Pressure:** ½ psi (0.03 bar).

**Life:** 100,000 cycles minimum at 1/2 psi maximum pressure each cycle and at maximum rated electrical load.

#### Electrical Rating—Relay Switching Capacity:

3 amps at 115 V AC at 50/60 Hz.

Power consumption: 4.5 watts at 120 vAC.

**Contact Arrangement:** SPDT NC (single pole, double-throw snap action switch; contacts are in normally closed position before pressure is applied to the diaphragm.)

#### Electrical Connections:

5 numbered terminals, pressure clamp screw type.

#### Conduit Opening:

7/8" diameter opening accepts 1/2" conduit.

#### Sample Line Connectors:

Two ¼"—18 NPT female fittings.

#### Shipping Weight:

AFS - 953 (std. enclosure): 5 lbs.

AFS - 953 - 1 NEMA 4 enclosure: 8 lbs.

AFS - 953 - 2 NEMA 7/9 enclosure: 18 lbs.

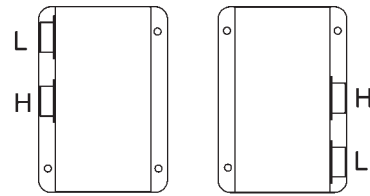

H: HIGH POSITIVE → L: LOW POSITIVE  
 POSITIVE → NEGATIVE  
 LOW NEGATIVE → HIGH NEGATIVE

Figure 1: Sample Line Connections

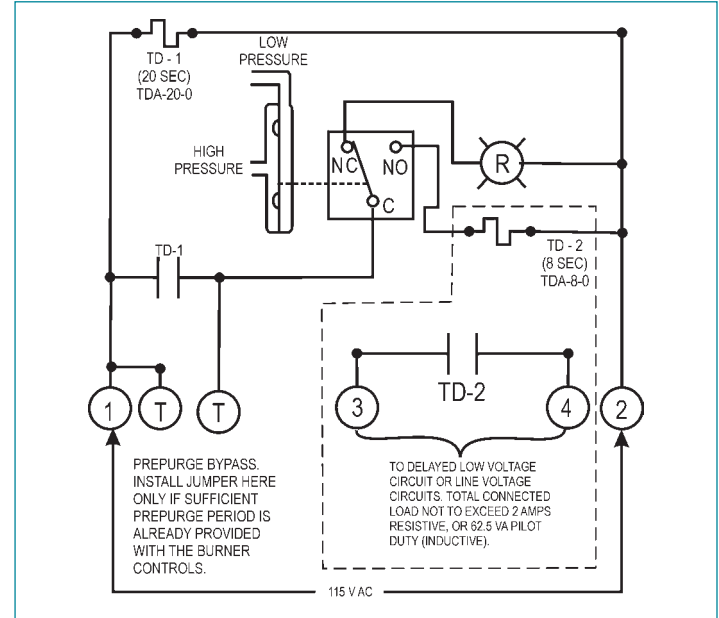
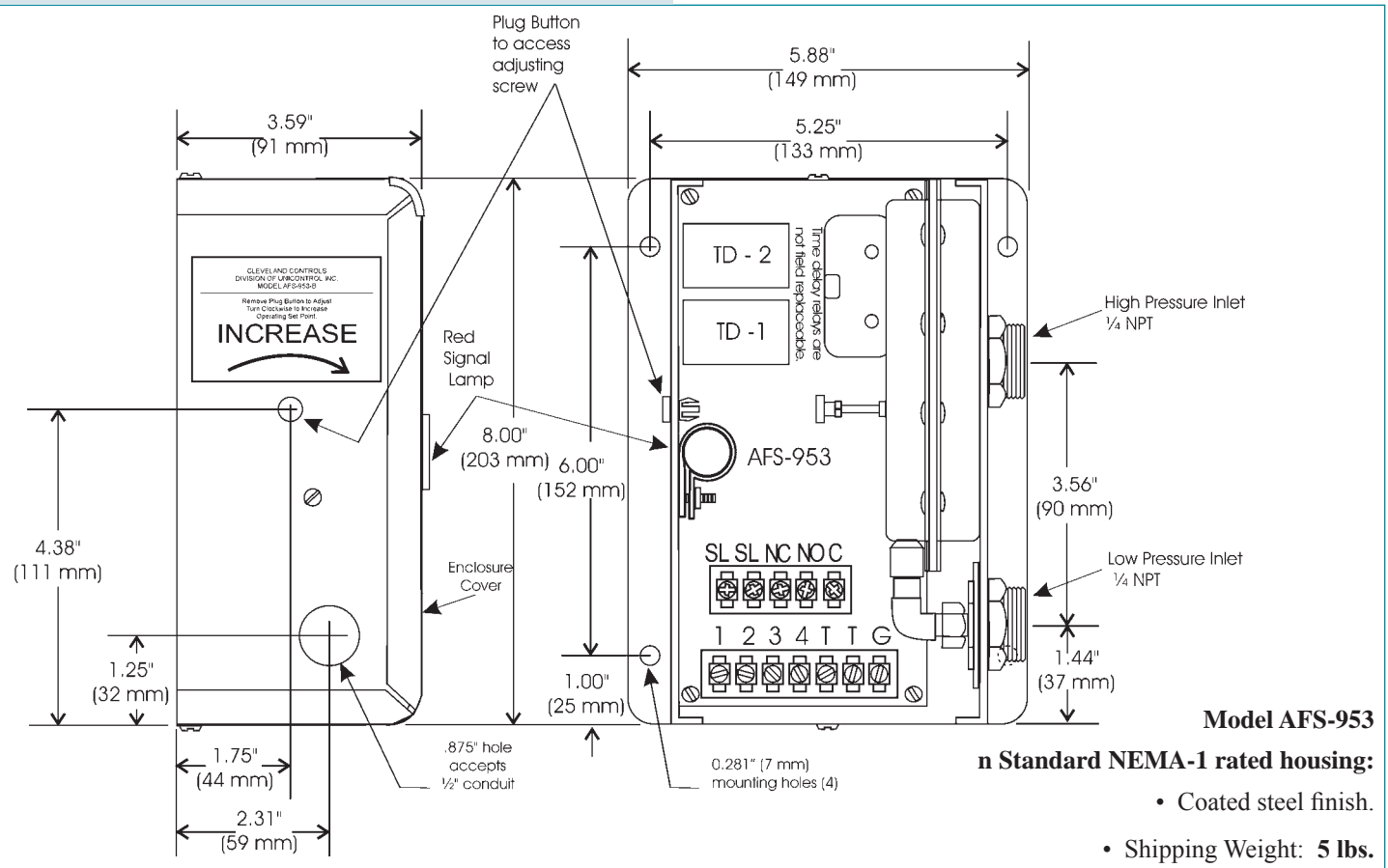

Figure 2: "Shelf" Condition: AFS-953 contacts before pressure and power are applied.



Model AFS-953

n Standard NEMA-1 rated housing:

- Coated steel finish.

- Shipping Weight: 5 lbs.

## ENCLOSURE SPECIFICATIONS & DIMENSIONS

### Model AFS-953-1:

14-gauge grey hammertone enameled steel with neoprene gasketed clamped cover hinged on the left side. **NEMA 4** rated: provides protection from dust, dirt, oil, and water.

Shipping Weight: **8 lbs.**

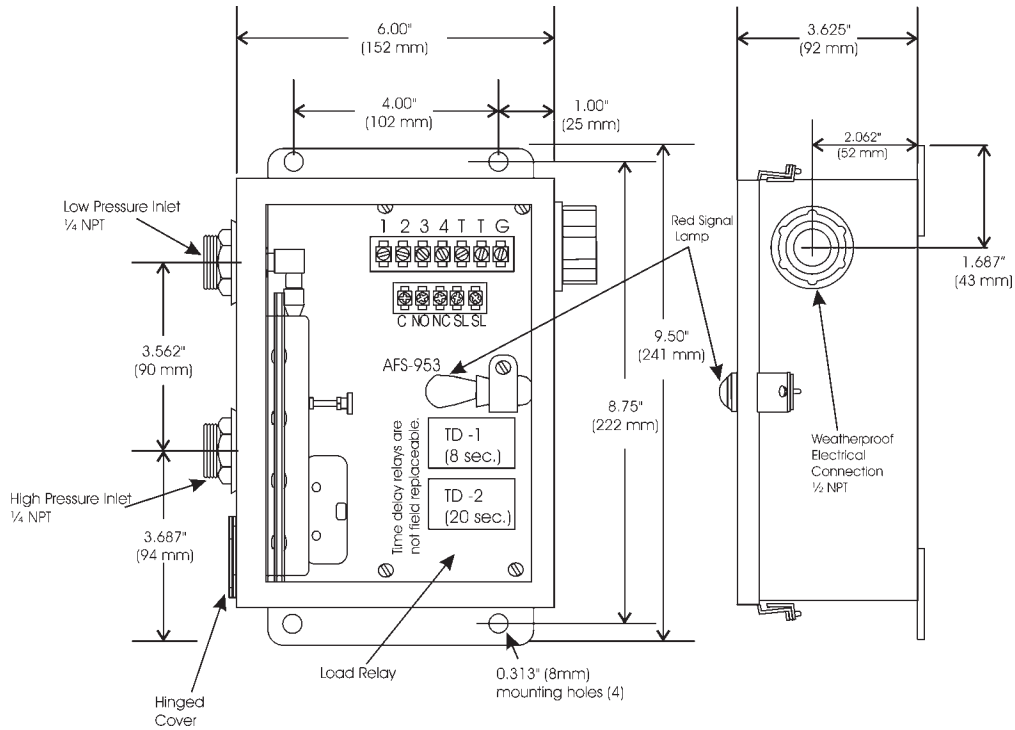

### Model AFS-953-2:

**NOTE: Red lamp not available.**

Cast aluminum alloy, nonmagnetic, non-sparking, and non-rusting. **NEMA 7** and **NEMA 9** rated. **UL** approved for **Class 1, Group D; Class II, Groups E, F, G.**

**Piping:** Either pressure inlet, if not connected to a pressure sample, must be piped and vented to a nonhazardous area.

Shipping Weight: **18 lbs.**

