



AIR PRESSURE SENSING SWITCH KIT WITH ADJUSTABLE SET POINT

APPLICATION

Series RSS-498-013 Air Sensing Switch Kits contain compact, economical Series RSS-498 switches designed for residential furnace and light commercial aftermarket applications. The RSS-498 switches have an adjustable set point range of 1.0"w.c. to 4.0"wc. (They have been factory set to actuate on a pressure rise of 1.0"w.c.) The field adjustability makes these switches ideal for numerous residential and light commercial HVAC applications.

GENERAL DESCRIPTION & OPERATION

The thermoplastic housing contains a diaphragm and snap-acting switch. Barbed sample line connectors on each side of the diaphragm accept flexible tubing. The electrical connection consists of male quick connect terminals.

The snap action switch can be actuated by a positive or negative pressure, or by a pressure differential.

MOUNTING (FIGURE 1)

Select a mounting location free from vibration. Mount with the diaphragm in any vertical plane in order to maintain the specified operating set point. Avoid mounting with the sample line connections directed upward. Surface mount via the two 0.14" slots in the bracket.

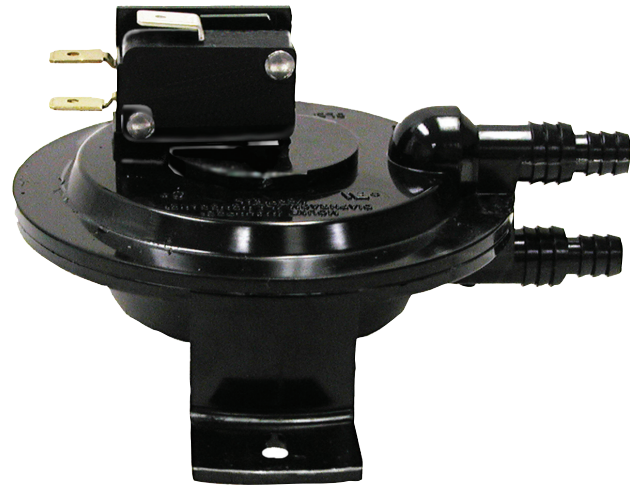

AIR SAMPLING CONNECTION (FIGURE 2)

The RSS switches are equipped with two 1/4" barbed slip-on sample line connections (situated on either side of the diaphragm), which will accept flexible tubing.

Refer to Figure 2 to identify the **High inlet (H)** and the **Low inlet (L)**. Connect the sample lines to the same port or ports as the switch being replaced.

Positive Pressure Only: Connect the sample line to H; L remains open to the atmosphere.

Negative Pressure Only: Connect the sample line to L; H remains open to the atmosphere.

Two Negative Samples: Connect higher negative sample to L; lower sample to H.

Two Positive Samples: Connect higher positive sample to H; lower sample to L.

One Positive and One Negative: Connect positive sample to H; connect negative sample to L.

ELECTRICAL CONNECTIONS

The snap switch has male quick-connect terminals. Before pressure is applied to the diaphragm, the switch contacts will be in the normally closed (NC) position as shown in **Figure 3**.

Reconnect existing wiring to the same terminals as the switch being replaced, i.e., NC, NO, and C.



FIELD ADJUSTMENT (FIG. 4)

The adjustable set point range of the RSS-498 is 1.0"w.c. to 4.0"w.c., ± 0.05 "w.c. The switch leaves the factory calibrated at 1.0"w.c. To adjust the set point, insert the adjusting tool (provided with the kit) into the adjusting screw located between the mounting feet on the underside of the switch. With the adjusting screw facing, turn clockwise to the desired set point. The maximum number of turns is 4, covering the set point range of 1.0 to 4.0"w.c. **Do not exceed the maximum number of turns.** Each full turn represents approximately 0.75"w.c. Determine the number of turns required to approximately position the adjusting screw as follows:

$$\frac{(\text{required set point} - \text{initial set point @ 1.0})}{0.75}$$

= number of turns clockwise

Example:

required set point = 2.5"w.c.

initial (factory) set point = 1.0"w.c.

$$(2.5 - 1.0) / 0.75 = 2 \text{ turns}$$

RSS-498 Set Point Adjustment						
Set Point Inches Water Column ("w.c.)	4.00					
	3.50					
	3.00					
	2.50					
	2.00					
	1.50					
	1.00					
	0.50					
	0.00					
		0.00	1.00	2.00	3.00	4.00
Turns of Set Point Adjustment Screw (from starting point at 1.0"w.c.)						

Figure 4

Please note:

(1) To precisely calibrate a Cleveland Controls air switch, a digital manometer is recommended to confirm set point at actual operating temperature.

(2) **Warning:** do not use this control if the set point of the original switch is not known. **Improper setting could result in a hazardous condition.**

(3) After calibration, use **only Loctite ASSURE 425™**, or equivalent cyanoacrylate ester, to seal the adjusting screw.

Nominal Dimensions in Inches (Millimeters)

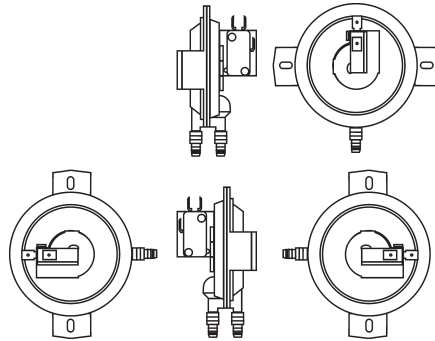
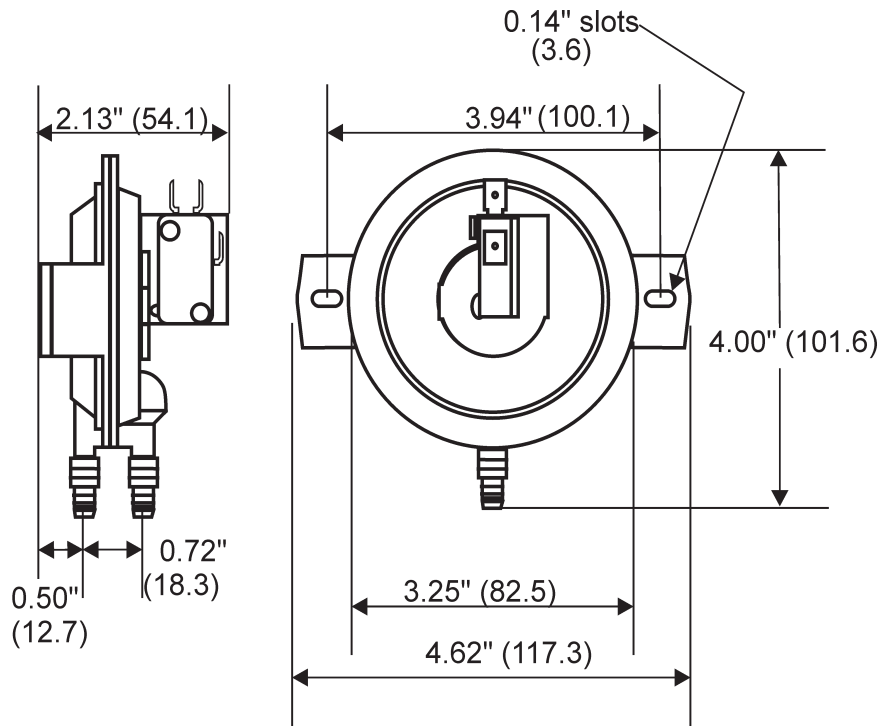

Fig. 1: Mount with the diaphragm in any vertical plane. Sample line connections should not point up.

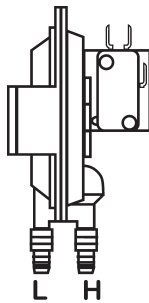

Fig. 2

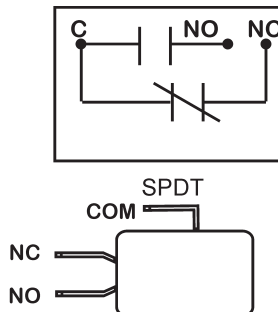

Fig. 3: Without pressure applied to the diaphragm, the switch contacts are in the position shown above.

SPECIFICATIONS MODEL RSS-498-013

Mounting Position:

Mount with the diaphragm in any vertical plane.

Set Point for RSS 498-013:

Factory set at 1.0"w.c. ± 0.05 "w.c..

Adjustable range:

1.0 ± 0.05 " w.c. to 4.0 ± 0.05 "w.c.

Measured Media:

Air

Maximum Pressure:

1 psi (0.06 bar)

Operating Temperature Range:

-40F to 190F (-40 to 88C)

Life:

100,000 cycles minimum at 1 psi maximum pressure each cycle and at maximum rated electrical load.

Electrical Rating:

5 amp noninductive 120 to 277 V AC

1 amp pilot duty (120 Va) at 120 VAC

Contact Arrangement:

SPDT

Electrical Connections:

(3) male quick-connect terminals, 90°, in compliance with NEMA standards.

Sample Line Connectors:

Barbed fittings will accept 1/4" ID or

3/8" ID flexible, slip-on tubing.

Approvals:

UL, CUL, CSA, CE, Australian Gas Association

Shipping Weight:

1/4 lb, approx.

RSS Sensing Switches are manufactured by Cleveland Controls Div. of UniControl Inc.

Accessories included:

P/N 28427 Contractor Kit