

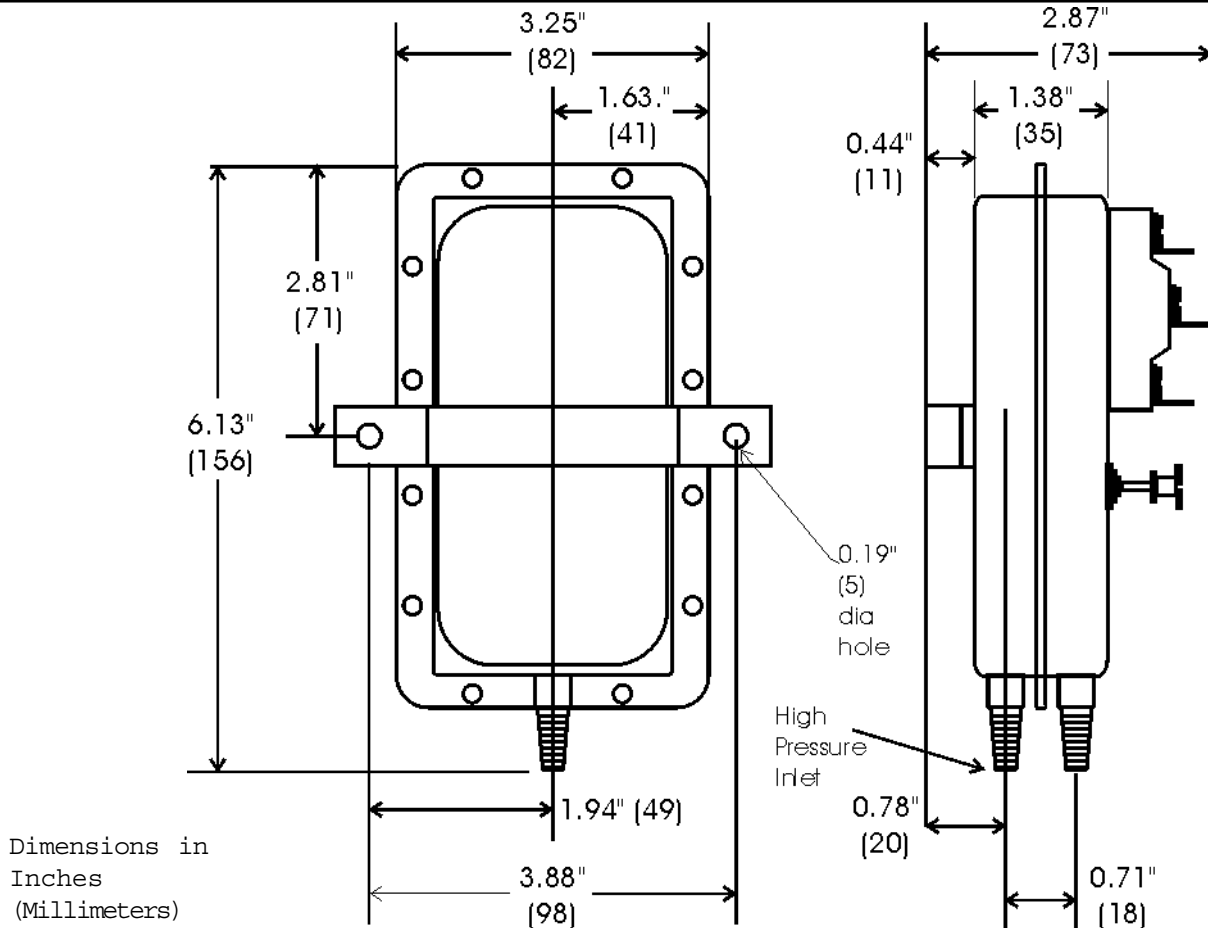

Cleveland Controls
 Division of UniControl Inc.

Model AFS-304-112

Open-Mounted Adjustable Set Point Air Pressure Sensing Switch



Dimensions in
 Inches
 (Millimeters)

Application

The **Model AFS-304-112** is a general purpose proving switch with gold contacts designed for HVAC, Energy Management and DDC (Direct Digital Control) applications. Gold-contact switches are commonly used in computer environments, direct digital control, or wherever low ampere currents are wired. It may be used to sense positive, negative, or differential air pressure. The **AFS-304-112** is equipped with convenient barbed sample line connectors that accept flexible tubing.

Description & Operation

The plated housing contains a diaphragm, a calibration spring and a snap-acting SPDT switch with gold contacts. The sample connections lo-

cated on each side of the diaphragm accept flexible tubing.

Mounting (Fig. 1)

Select a mounting location which is free from vibration. The **AFS-304-112** must be mounted with the diaphragm in any vertical plane in order to obtain the lowest specified operating set point. Avoid mounting with the sample line connections in the "up" position. Surface mount via the two 3/16" diameter holes in the integral mounting bracket. The mounting holes are 3-7/8" apart.

Air Sampling Connection (Fig.2)

The **AFS-304-112** is designed to accept flexible tubing by means of the barbed sample connections. Locate the sampling probe a minimum of 1.5

duct diameters downstream from the air source. Install the sampling probe as close to the center of the airstream as possible. Refer to **Figure 2** to identify the high pressure inlet (**H**) and the low pressure inlet (**L**). Select from the five application options listed below, and connect the sample lines as shown.

POSITIVE PRESSURE ONLY: Connect the sample line to inlet H; inlet L remains open to the atmosphere.

NEGATIVE PRESSURE ONLY: Connect the sample line to inlet L; inlet H remains open to the atmosphere.

TWO NEGATIVE SAMPLES: Connect the higher negative sample to inlet L. Connect the lower negative sample to inlet H.

(con't)

(Figure 1)

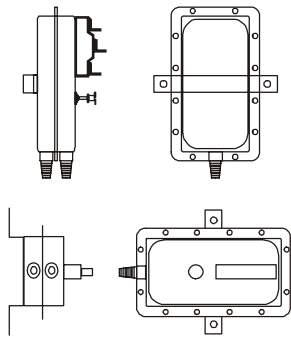

Mount with the diaphragm in any vertical plane to obtain the lowest specified operating set point.

(Figure 2)

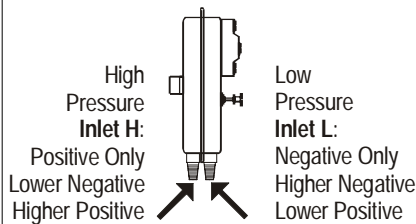

TWO POSITIVE SAMPLES: Connect the higher positive sample to inlet H. Connect the lower positive sample to inlet L.

ONE POSITIVE AND ONE NEGATIVE SAMPLE: Connect the positive sample to inlet H. Connect the negative sample to inlet L.

Electrical Connections (Fig. 3)

Before pressure is applied to the diaphragm, the switch contacts will be in the normally closed (NC) position. The snap switch has 1/4" 90-degree quick connect terminals. Wire alarm and control applications as shown in Fig. 4.

Field Adjustment

The adjustment range of an **AFS-304-112** Air Switch is 0.05 ± 0.02" w.c. to 2.0" w.c. To adjust the set point, turn the adjusting screw counterclockwise until motion has stopped. Next, turn the adjusting screw 4 complete turns in a clockwise direction to engage the spring. From this point, the next ten turns will be used for the actual calibration. **Each full turn represents approximately 0.2" w.c.**

Please note: To properly calibrate a Air Switch, a digital manometer or other measuring device should be used to confirm the actual set point.

(Figure 3)

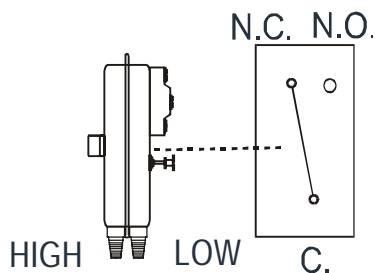

To prove excessive air flow or pressure:

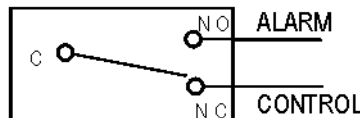

To prove insufficient air flow or pressure:

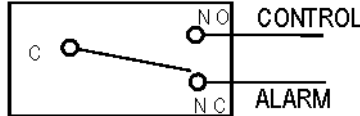

Location of Sample Lines for Typical Applications

<p>FAN OPERATION OR TRUE AIR FLOW WITH LITTLE OR NO STATIC PRESSURE.</p> <p>PROBE MUST BE PERPENDICULAR TO FLOW.</p>	<p>FAN OPERATION OR AIR FLOW WITH NO STATIC PRESSURE.</p>	<p>PROVE POSITIVE STATIC PRESSURE</p>
<p>FAN OPERATION AND TRUE AIR FLOW WITH VARYING AMOUNTS OF STATIC PRESSURE.</p> <p>PROBE MUST BE PERPENDICULAR TO FLOW.</p>	<p>SUCTION OR FAN OPERATION</p>	<p>NEGATIVE PRESSURE INCREASES AS FILTER GETS DIRTY.</p> <p>FILTER</p>

Specifications

Model AFS-304-112
Air Flow Switch

Mounting Position: Mount with the diaphragm in any vertical plane.

Set Point Range: 0.05 ± 0.02" w.c. to 2.0" w.c.

Field Adjustable "Operate Range": 0.05" w.c. to 2.0" w.c.

Field Adjustable "Release Range": 0.02" w.c. to 1.9" w.c.

Approximate Switching Differential: Progressive, increasing from 0.02 ± 0.01" w.c. at minimum set point to approximately 0.1" w.c. at maximum set point.

Measured Media: Air, or combustion by-products that will not degrade silicon.

Maximum Pressure: 1/2 psi (0.03 bar)

Operating Temperature Range: -40F to 180F (-40 to 82C)

Life: 100,000 cycles minimum at 1/2 psi maximum pressure each cycle and at maximum rated electrical load.

Electrical Rating:

300 VA pilot duty at 115 to 277 VAC, 15 amps noninductive to 277 VAC, 10 ma at 5 VDC (applies to dry circuit applications).

Contact Arrangement: SPDT

Electrical Connections: 1/4" 90-degree quick connects.

Sample Line Connections: Two barbed 1/4" connectors accept flexible tubing.

Approval: UL, CSA pending

Shipping Weight: 1.2 lbs.

Accessories

- Sample line probes.
- Orifice plugs (pulsation dampers).



Cleveland Controls

Division of UniControl Inc.

1111 Brookpark Rd Cleveland OH 44109

Tel: 216-398-0330

Fax: 216-398-8558

Email:

salesvac@unicontrolinc.com

Web page:

<http://www.clevelandcontrols.com>