



Cleveland Controls
Division of UniControl Inc.

Model
AFS-951

Adjustable Set Point Air Pressure Sensing Switch



AFS-951 in Standard Enclosure,
rated NEMA-1.



AFS-951-1 in NEMA-4 rated
Enclosure.



AFS-951-2 in NEMA-7 and
NEMA-9 rated Enclosure.

Description & Operation

The **Cleveland Controls AFS-951 Differential Pressure Sensing Switch** is designed to provide precise operation and convenient features for industrial and commercial air handling applications. The **AFS-951** can monitor positive, negative, or differential pressure (flow) of air and non-combustible gases, and is commonly used to monitor combustion air, furnace pressure, ventilating blower operation, inflatable structure pressure, fume hood operation, bag house air flow, dirt accumulation in air filters, and heat-transfer air flow. The **AFS-951** has a field-adjustable set point range of 0.05"wc to 12.0"wc.

Common Applications

The most common specific application for the **AFS-951** is as a **Low**

Draft (Negative Pressure) Cutoff Safety Switch for combustion draft control systems.

The general applications of the **AFS-951** are:

- **Low Positive Pressure Cutoff.** (Shutdown upon insufficient pressure.)
- **Low Negative Pressure Cutoff.** (Shutdown upon insufficient draft.)
- **Low Differential Pressure Cutoff.** (Shutdown upon insufficient difference between two samples.)

Mounting

The **AFS-951** is available in 3 enclosures designed for surface mounting on any flat, relatively stable surface free of vibration. To obtain the lowest operating set point specification, the control must be mounted with the diaphragm vertical (Fig 1).

The standard enclosure has mounting flanges with four 9/32" mounting holes as shown on page 4. The NEMA-4 rated model has mounting flanges with four 5/16" mounting holes as shown on page 3. The NEMA-7/NEMA-9 rated enclosure has two mounting slots as shown on page 3.



Cleveland Controls
Division of UniControl Inc.
1111 Brookpark Rd
Cleveland OH 44109

Tel: 216-398-0330
Fax: 216-398-8558
Email: salesvac@unicontrolinc.com
Web page: <http://www.clevelandcontrols.com>

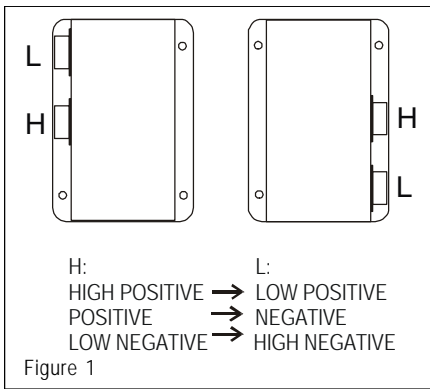

Figure 1

Piping

The field sample line connectors, two 1/4" - 18 NPT female fittings, labeled **H (high)** and **L (low)**, are located on the side of the enclosure as shown in Figure 1.

For sample lines up to 10 ft., use 1/4" OD tubing or 1/8" pipe.

For sample lines up to 20 ft., use 1/4" ID tubing or 1/4" pipe.

For sample lines up to 60 ft., use 1/2" ID tubing or 1/2" pipe.

For sample lines up to 90 ft., use 3/4" ID tubing or 3/4" pipe.

For sample lines up to 120 ft., use 1" ID tubing or 1" pipe. For each right angle bend, add four feet to the computed line length in order to determine correct pipe or tubing size.

If either sample line connector is vented to the atmosphere, attach an elbow to it so that the open end of the connector points downward. This will help protect the switch from contamination.

Sample Line Connections

Positive Pressure only:

Connect sample line to **H**;
L remains open to the atmosphere.

Negative Pressure only:

Connect sample line to **L**;
H remains open to the atmosphere.

Two Negative Samples:

Connect higher negative sample to **L**;
Connect lower negative sample to **H**.

Two Positive Samples:

Connect higher positive sample to **H**;
Connect lower positive sample to **L**.

Figure 2: Electrical Connections

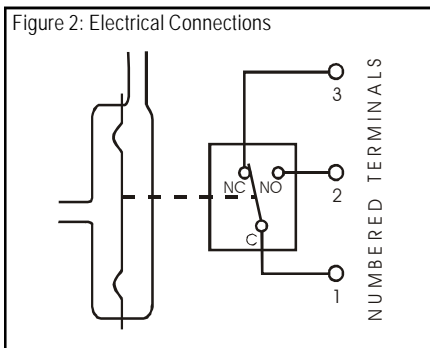

One Negative and One Positive

Sample:

Connect positive sample line to **H**;
Connect negative sample line to **L**.

Electrical Connections

Three (3) terminals are provided for field wiring. Before pressure is applied to the diaphragm, the switch contacts will be in the normally closed position as shown in Figure 2.

To Prove Excessive Air Flow or Pressure:

Connect Terminal 1 to a hot line, Terminal 2 to an alarm circuit (if desired), and Terminal 3 to the control circuit.

To Prove Insufficient Air Flow or Pressure:

Connect Terminal 1 to a hot line, Terminal 2 to the control circuit, and Terminal 3 to an alarm circuit (if desired).

NOTE: When the switch is wired in this manner, an alarm circuit will be energized at start up, and will stay energized until the set point of the air switch is satisfied. To avoid nuisance alarm, a time delay, equal to the amount of time required for pressure to activate the air switch, should be wired in series between Terminal 3 and the alarm device.

Field Adjustments

Field adjustments to the operating set point are made by removing the protective plug button on the side of the control enclosure and inserting a standard blade-type screwdriver, at least 3 inches long*.

The adjustment range is **0.05" w.c. to 12.0" w.c.** To adjust the set point, turn the adjusting screw counterclockwise until motion has stopped. Next, turn the adjusting screw **4 complete turns** in a clockwise direction to engage the spring. For the **next 10 turns, each full turn represents approximately 1.2" w.c.** At higher operating pressures, there is a slight increase in the switching differential. **Please note:** To properly calibrate an air pressure sensing switch, a digital manometer or other measuring device should be used to confirm the actual set point.

SPECIFICATIONS

MODELS: AFS-951,
AFS-951-1, AFS-951-2

Air Pressure Sensing Switch

ELECTRICAL RATING:

300 VA pilot duty at **277 v AC**
260 VA pilot duty at **240 v AC**
130 VA pilot duty at **120 v AC**
15 amp noninductive to **277 v AC**.

CONDUIT OPENING:

7/8" diameter opening accepts 1/2" conduit fitting.

ELECTRICAL SWITCH

(Contact Arrangement): SPDT NC

Single pole, double throw snap-action switch. Contacts in a normally closed position before pressure is applied.

CONTROL SET POINT / ADJUSTABLE OPERATING RANGE:

Field-adjustable, 0.05 ± 0.02 to 12.0" w.c.;
(1.3 to 305 mm w.c.; 0 to 0.43 psi)

SWITCH DIFFERENTIAL:

0.02 ± 0.01" w.c. at minimum set point, to approximately 0.8" w.c. at maximum set point
(0.5 ± .25 mm to approximately 20.3 mm).

MAXIMUM PRESSURE:

1/2 PSI (0.03 bar)

ELECTRICAL CONNECTIONS:

Numbered terminal panel

RECOMMENDED OPERATING POSITION:

Mount with the diaphragm vertical to obtain the lowest operating set point.

OPERATING TEMPERATURE RANGE:

- 40 TO 180F (- 40 to 82C)

SAMPLE LINE CONNECTORS:

Two 1/4"—18 NPT female fittings.

APPROVALS: UL listed. **CSA** and **FM** approved.

Pressure Conversion Table

1"wc = 0.0361psi
or 0.0736"Hg
1"Hg = 0.491psi
or 13.6" wc
1psi = 27.7"wc
or 2.036"Hg

ENCLOSURE SPECIFICATIONS & DIMENSIONS

Model AFS-951-1:

14-gauge grey hammertone enameled steel with neoprene gasketed clamped cover hinged on the left side. **NEMA 4** rated: provides protection from dust, dirt, oil, and water.

Shipping Weight: **8 lbs.**

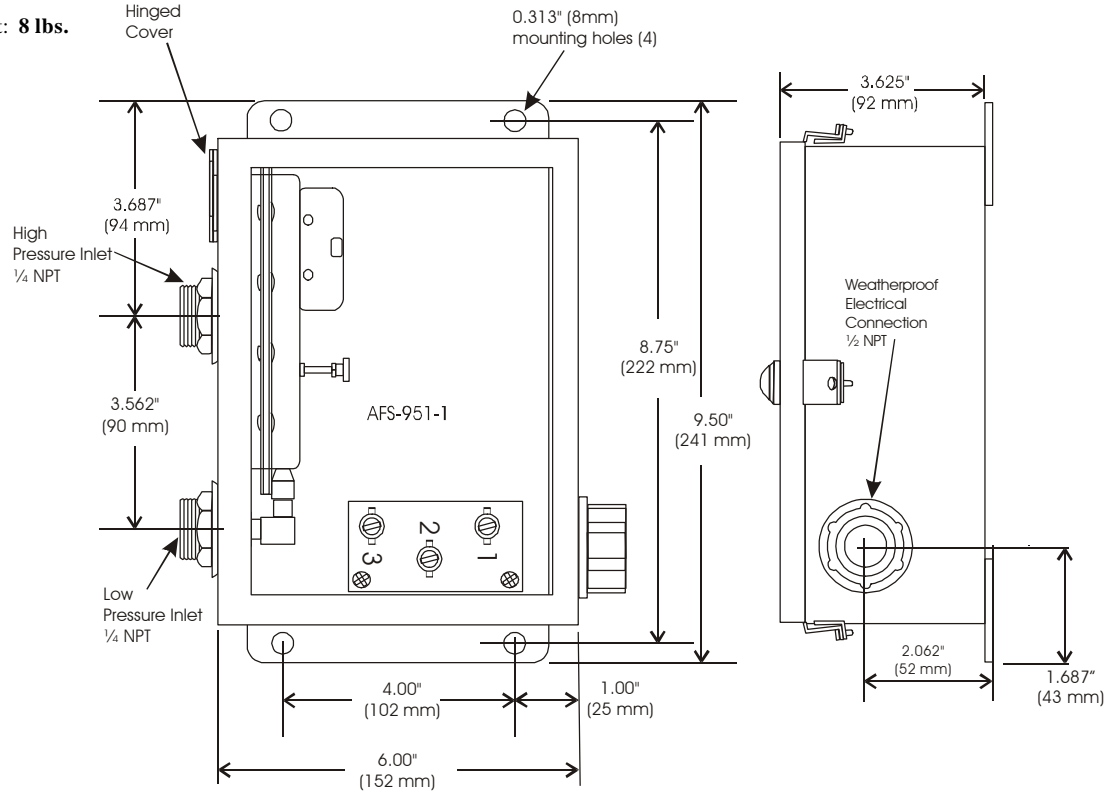

Model AFS-951-2:

Cast aluminum alloy, nonmagnetic, non-sparking, and non-rusting. **NEMA 7** and **NEMA 9** rated. **UL** approved for **Class 1, Group D; Class II, Groups E, F, G.**

Piping: Either pressure inlet, if not connected to a pressure sample, must be piped and vented to a nonhazardous area.

Shipping Weight: **18 lbs.**

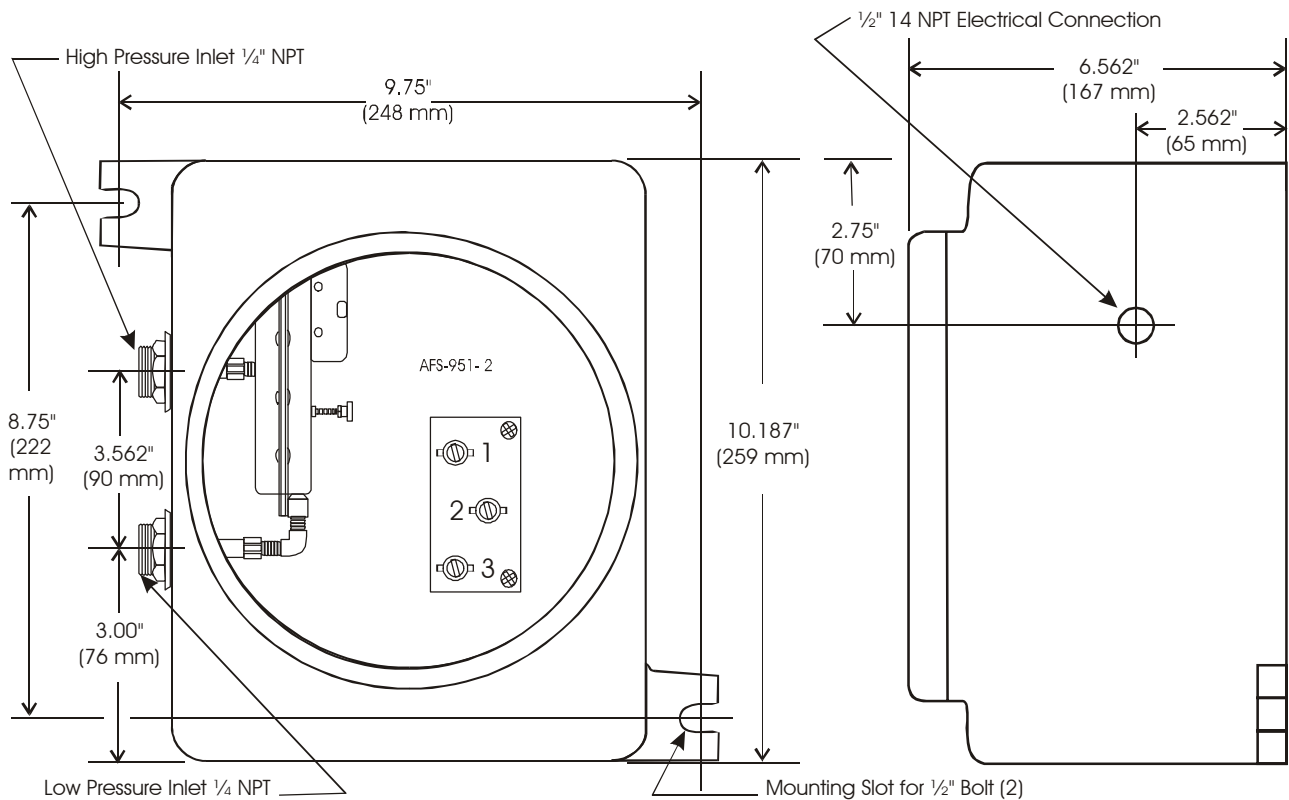

Model AFS-951 in Standard NEMA-1 rated housing:

- Coated steel finish.
- Shipping Weight: **5 lbs.**

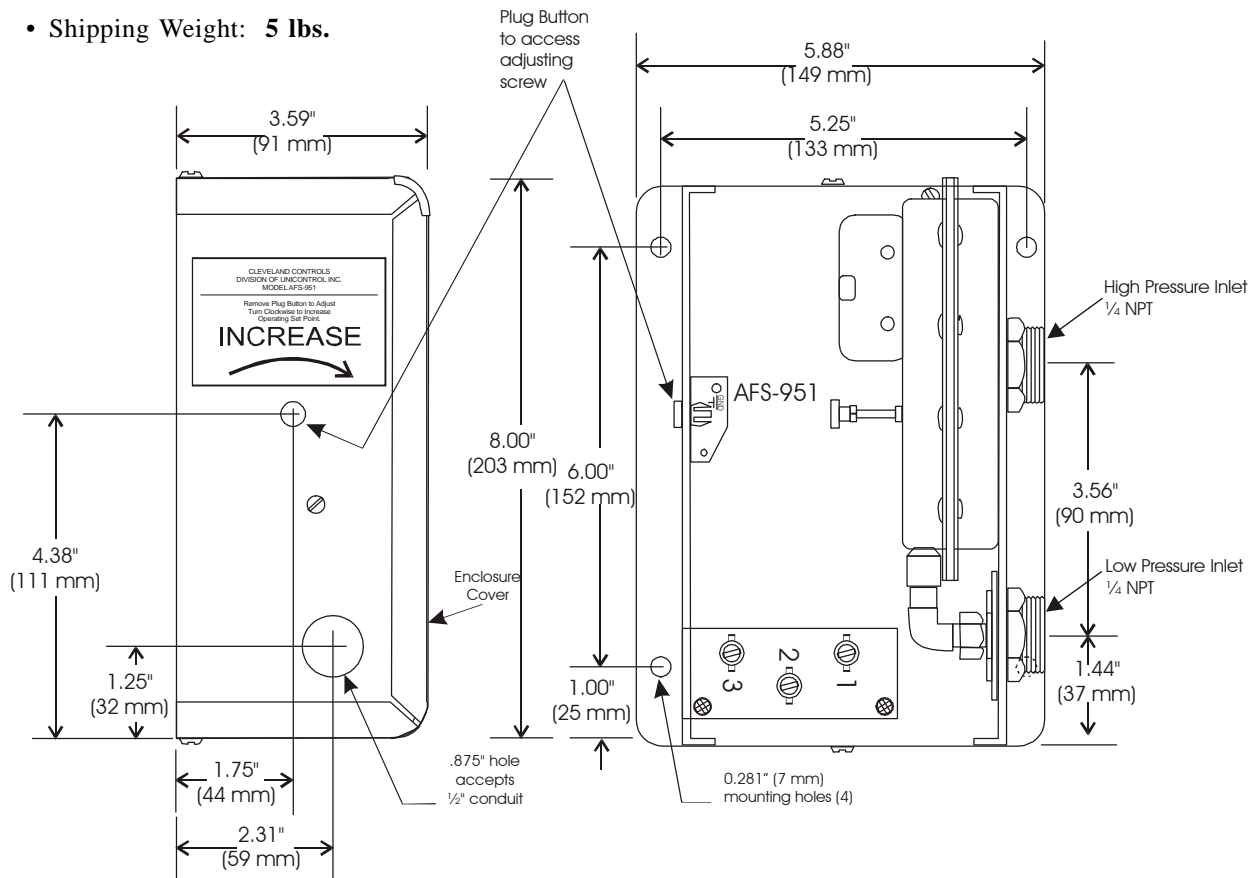

Distributed by:

Are you reading a FAX
or a COPY of this bulletin?
DOWNLOAD the full-color PDF
version of this and other
literature at our website!

Visit us on the World Wide Web at www.clevelandcontrols.com

for HVAC Sales:

Cleveland Controls Div. of UniControl Inc.

1111 Brookpark Road

Cleveland OH 44109

Telephone: 216.398.4414

Fax: 216.398.8558

Email: salesvac@unicontrolinc.com

for Combustion Control Sales:

Hays Cleveland Div. of UniControl Inc.

1903 South Congress Avenue

Boynton Beach FL 33426

Telephone: 561.734.9400

Fax: 561.734.8060

Email: salescombustion@unicontrolinc.com