

STANDARD FEATURES

- Industrial boiler applications for oxygen trim & monitoring.
- Economical industrial design.
- Field repairable without removal from stack.
- In situ zirconium oxide (ZrO_2) probe.
- Standard flame arrester.
- Two calibration methods using single calibration gas.
- Monitors excess air levels for safety.
- High accuracy: $\pm 2\%$ full scale.
- Response time < 1 second.
- Update for Model A-08560 probes.
- Used with Model A-10050-A0 Electronics to provide many features such as Combustion Efficiency, Probe Diagnostics, and I/O for Control & Safety.
- Room air is used as reference: eliminates the cost of instrument air.

INTRODUCTION

Hays Cleveland is a pioneer in the development and application of zirconium oxide probes for flue gas oxygen analyzers. The Model A-08562-A0 MINI-O2™ Analyzer is the latest version of the industrial oxygen analyzers designed specifically for control and monitoring of fire tube boilers. The A-08562-A0 MINI-O2™ Analyzer updates the Series A-08560 Pygmy Probe™ Oxygen Analyzers.

The A-08562-A0 MINI-O2™ Analyzer components include the probe (consisting of an 8"-insertion zirconium oxide cell, type K thermocouple, and cell heater) with microprocessor analyzer electronics (indicator/transmitter components*) a cable to connect the probe to the electronics unit, and one of two calibration methods.

* Refer to Bulletin BA10050A0.00.

The manual calibration method was commonly used with the earlier version of the MINI-O2™ Analyzer (the Model A-08561). This method does not provide a flow (calibration) panel. The user provides

Model A-08562-A0 Zirconium Oxide In Stack MINI-O2™ Flue Gas Oxygen Analyzer



the 4.5% nominal O_2 in N_2 calibration gas in a cylinder and a flow meter. Typically, this method is recommended for monitoring applications only.

The semi-automatic method uses a manual flow (calibration) panel (Model -C06), and calibration gas cylinder 4.5% nominal O_2 in N_2 (Model -FZ1 and FZ2) and dry instrument air. This method is recommended for control or safety applications.

The analyzer components are field repairable or replaceable without removal of the probe from the stack. Convenient maintenance kits, available from Hays Cleveland, save time and expense.

Distributed by:

SPECIFICATIONS

Series A-08562-A0 MINI-O2™ Zirconium Oxide In Stack Oxygen Analyzer Probe	
Range	0-1% to 0-25%.
Response Time	1 second (initial).
Accuracy	± 2% full scale.
Fuel Types	Gas, oil, solid fuels.
Probe Insertion Length	8 inches.
Probe Material	High temperature alloy and 304 SS.
Cable, Probe-to-Electronics	20' (standard); 50' or 75' optional; multiconductor in weather-tight flexible conduit.
Probe Access Box	Hinged, weatherproof, painted steel.
Ambient Temperature Range	Junction box and probe-to-electronics cable: not to exceed 176F (80C). Flue gas stream (in stack components): not to exceed 800F (427C).
Calibration Tubing Fitting	1/8" ferrule-type (Swagelok™ type).
Calibration Gas Flow	0.8L/minute.
Electronics	See Series A-10050-A0 Microprocessor O ₂ Analyzer Electronics specification.
Shipping Weight	with 20' pre-wired cable <20 lbs. with 50' pre-wired cable <30 lbs. with 75' pre-wired cable <50 lbs.

NOMENCLATURE

Base Model: A-08562 -A0	
Codes	Description
Base	A-08562 -A0 -
Probe Selection	
B01	Probe, 8" probe, standard.
Electronics Options: Refer to Bulletin BA10050A0.	
Calibration Method	
C00	Manual Calibration, without flow (calibration) panel.
C05	Air filter to dry instrument air; air set with gauge and manual drain. Use with C06.
C06	Semi-automatic Flow (Calibration) Panel: uses manually operated valves and flow meters for reference air and calibration gas, DIN size, one per probe required.
Probe-to-Electronics Cables	
D01	Cable, prewired, 20 feet.
D02	Cable, prewired, 50 feet.
D03	Cable, prewired, 75 feet.
Calibration Gas Accessories	
FZ1	Calibration gas, 4.5 to 5.0% oxygen in nitrogen (O ₂ in N ₂), disposable cylinder.
FZ2	Dual stage regulator and gauges for FZ1.

Typical Model Code: A-08562-A0-B01-C00-D01

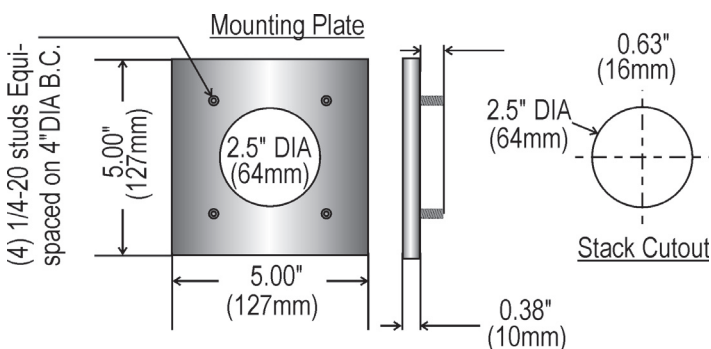
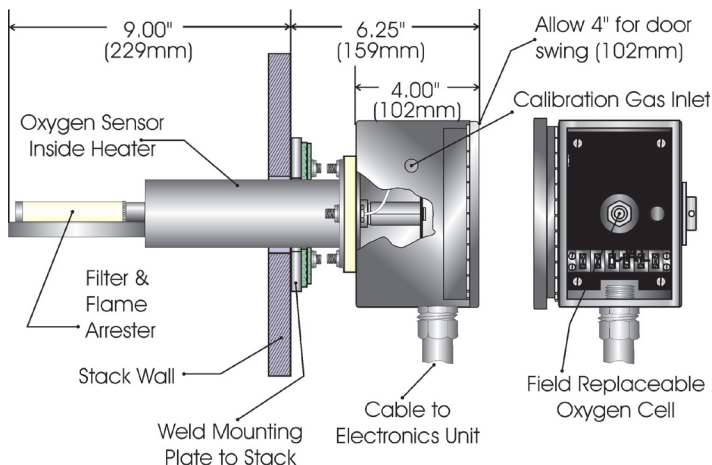

Visit us on the World Wide Web at www.hayscleveland.com
Hays Cleveland Div. of UniControl Inc.
1903 South Congress Avenue
Boynton Beach FL 33426

Telephone: 561.734.9400
Fax: 561.734.8060
e-mail: salescombustion@unicontrolinc.com

www.hayscleveland.com

Hays Cleveland Div. of UniControl Inc.
1111 Brookpark Road
Cleveland OH 44109

Telephone: 216.398.4414
Fax: 216.398.8558
e-mail: salescombustion@unicontrolinc.com

Are you reading a FAX or a COPY of this bulletin? DOWNLOAD the full-color PDF version of this and other literature at our website!