

STANDARD FEATURES

- O₂ trim & monitoring for fire & water tube boilers.
- In-situ field-repairable probe.
- 18"-24" adjustable insertion length.
- Stable probe reduces calibration frequency.
- Rated for industrial service.
- Flame arrestor option.
- Semi-automatic & automatic calibration methods.
- Single calibration gas.
- High accuracy, +/- 2% full scale.
- Response time less than 1 second.
- Used with Model A-10050-A0 Electronics to provide many features such as Combustion Efficiency, Probe Diagnostics, and I/O for Control & Safety.

INTRODUCTION

Hays Cleveland is a pioneer in the development and application of zirconium oxide probes for flue gas oxygen analysis. The Model A-10018-A0 OXY-MIZER™ has long been recognized as the most reliable and stable probe for both fire and water tube industrial boilers. Now this analyzer is offered with our state of the art electronics, Model A-10050-A0.

The OXY-MIZER™ probe's patented zirconium oxide cell with low voltage heater and high temperature RTD offers remarkable stability and accuracy. The adjustable insertion length of the probe adapts to both fire tube and water tube boiler applications. The use of the RTD to control the heater temperature is unique to our design and is the basis for its stability compared to probes using thermocouples for cell temperature control.

The components of the OXY-MIZER™ include the probe, electronics, cable and flow (calibration) panel, with one set of regulator and gauges. Semi-automatic and automatic calibration options are available. Typically, because of the stability of the probe, the semi-automatic calibration method is employed

Model A10018-A0 Zirconium Oxide In Stack OXY-MIZER™ Oxygen Analyzer Probe

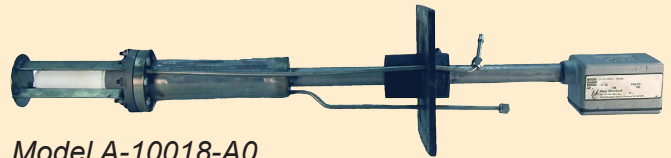

Model A-10018-A0
O₂ Analyzer Probe



Model A-10050-A0
O₂ Analyzer Electronics

unless auto-calibration is a site requirement. The semi-automatic calibration method includes a flow panel (Model C06) for continuous control of the reference air and for calibration air. This probe requires only a single calibration gas (nominal 4.5% O₂ in N₂) supplied in a cylinder with a regulator and gauges (Model FZ1-FZ2). An annual calibration check is recommended.

The Model A-10050-A0 Oxygen Analyzer Electronics controls the heater to maintain the probe at a constant temperature for accuracy and long cell life. RS 485 Modbus communications is standard. Inputs for fuel type(s), flue gas temperature and combustion air temperature are options for computing combustion efficiency. The Model A-10050-A0 electronics replaces earlier electronics units, Series A-10018-B0 and A-10021-B0. For more information, please refer to Bulletin BA10050A0.

Distributed by:

SPECIFICATIONS

Series A-10018-A0 OXY-MIZER™ Zirconium Oxide In Stack Oxygen Analyzer Probe	
Fuel Types	Gas, oil, coal, bagasse, biomass, wood.
Power Requirements	115 VA ± 15% 50/60 Hz., 170 VA startup, 40-100 VA operating, with A-10050-A0 Electronics.
Range	0-1% to 0-25% with A-10050-A0 Electronics.
Response Time	Initial within 1 second in flue gas through filter.
Accuracy	±2% full scale, complete system.
Probe Insertion Length	Adjustable insertion, 18 to 24 inches (46 to 61 cm) tip to flange.
Filter	5 micron ceramic, bolt-on.
Cable, Probe-to-Electronics	20' (standard); 50' optional; multiconductor in weather-tight flexible conduit.
Probe Material	304, 316 & 446 SS, primary metals.
Flue Gas Temperature	-40 to 1000F (-40 to 538C), noncondensing.
Test Gas & Reference Air	Reference air: dry instrument air at 1LPM at 10 psig. Calibration air: dry instrument air at 2LPM at 10 psig. Calibration gas: nominal 4.5% O ₂ in N ₂ , 2LPM at 10 psig.
Connector Wiring	Quick disconnect; 3 shielded pairs in ¾" flex conduit.
Electronics	Refer to Bulletin BA-10050-A0 for Series A-10050-A0 Microprocessor O ₂ Analyzer Electronics.
Shipping Weight	With 20' pre-wired cable <20 lbs. With 50' pre-wired cable <30 lbs.

NOMENCLATURE

Model Code: A-10018 -A0 - _ - _ - _ - _ - _ - _ - _ - _ - _ -	
Codes	Description
Base	A-10018 -A0 -
Probe Selection	
A01	18" to 24" adjustable, in situ probe without flame arrestor.
A02	18" to 24" adjustable, in situ probe with flame arrestor.
Electronics Options: Refer to Bulletin BA10050A0.	
Calibration Method	
C05	Air filter for dry instrument air; air set with gauge and manual drain.
C06	Semi-automatic Flow (Calibration) Panel: uses manually-operated valves and flow meters for reference air and calibration gas; DIN size. One per probe required.
C07	Automatic Flow (Calibration) Panel: uses solenoid-operated valves.
Probe-to-Electronics Cables	
D02	Cable, prewired, 20 feet.
D04	Cable, prewired, 50 feet.
D05	Probe mating connector; customer-supplied cable; requires soldering by customer.
Calibration Gas Accessories	
FZ1	Calibration gas, 4.5 to 5.0% O ₂ in N ₂ (oxygen in nitrogen), disposable cylinder.
FZ2	Dual-stage regulator and gauges for FZ1.

Typical Model Code: A-10018-A0-A01-C05-C06-D02-FZ1-FZ2.

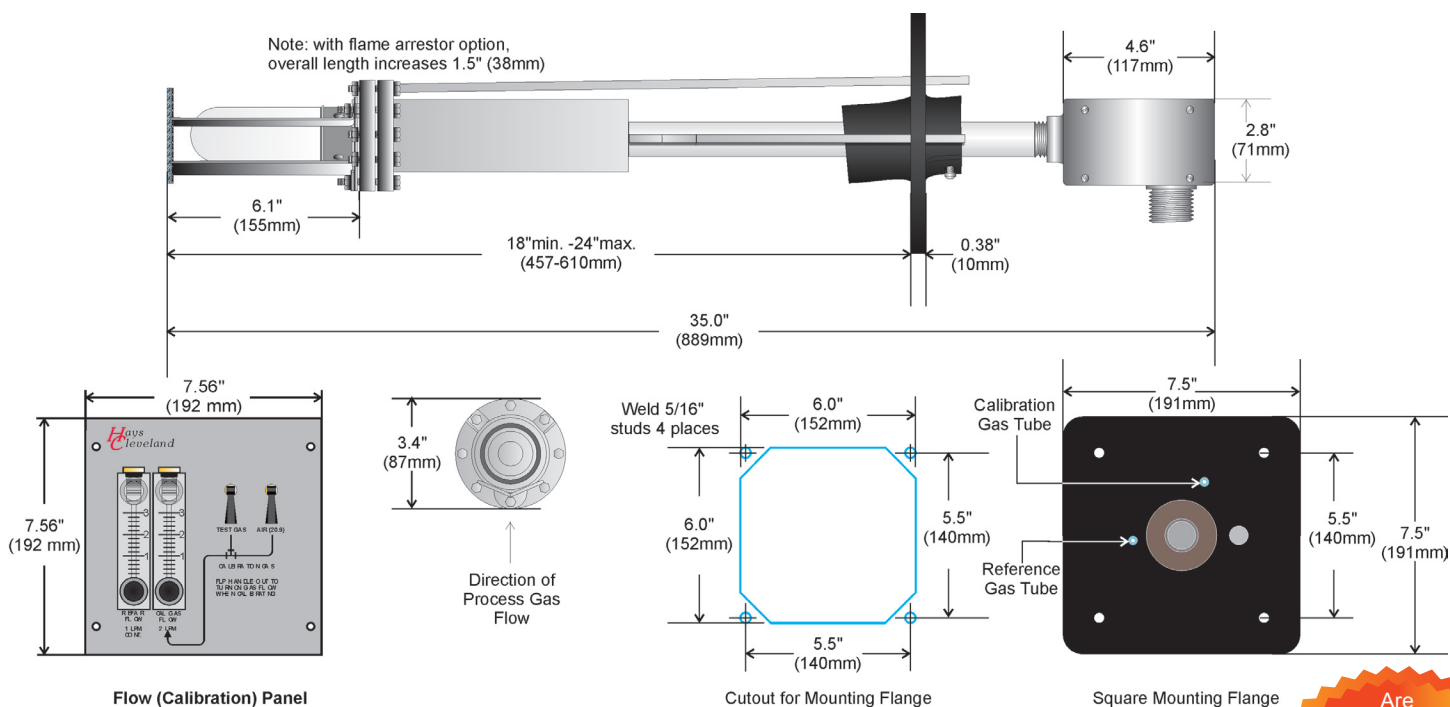

Visit us on the World Wide Web at www.hayscleveland.com

Hays Cleveland Div. of UniControl Inc.
1903 South Congress Avenue
Boynton Beach FL 33426

Telephone: 561.734.9400
Fax: 561.734.8060
e-mail: salescombustion@unicontrolinc.com

Hays Cleveland Div. of UniControl Inc.
1111 Brookpark Road
Cleveland OH 44109

Telephone: 216.398.4414
Fax: 216.398.8558
e-mail: salescombustion@unicontrolinc.com

Are you reading a FAX or a COPY of this bulletin? DOWNLOAD the full-color PDF version of this and other literature at our website!