

**AC** Multifunction Programmable  
**STATION** Controllers

- Multiloop controller
- Micro PLC
- Process computer

**in just one instrument!**



ISO 9001  
Certified

Distributed by:

# The new challenge in control strategy

Control and automation in the process and manufacturing industry demands increasing flexibility, a high level of integration of control functions and user friendly Human Machine Interface.

**AC STATION** controllers represent the single most effective and innovative solution to these demands. One AC STATION instrument can perform:

- Data acquisition and monitoring
- Regulation and control
- Complex mathematical functions
- Logic and sequencing
- Alarm functions
- Local monitoring of process data, control functions, alarms and events
- Automatic and manual commands.

This flexibility dramatically reduces control cubicle size, the number of components required, and the engineering time to develop an automation system.

- 4-8 analog inputs
- 4-8 analog outputs
- 8-32 digital inputs
- 8-32 digital outputs
- RS485 serial link, Modbus and J-bus Protocol (slave)
- Peer-to-Peer communications



A single key stroke to select one of 12 preprogrammed control strategies stored in the instrument's library.

Several bargraph, trend, alarm and menu pages displayed on a long life, clear, high-resolution LCD display.

Free, easy and quick programming of the required control strategy via a PC, thanks to a block structured architecture supported by AC-PROGRAPH, a graphic configuration software tool.

### Extensive Hardware

8 analog inputs,  
4 isolated analog outputs (expandable to 8)  
8 digital inputs +8 digital outputs (expandable to 32+32),  
3 serial ports  
and 1 high speed LAN port.  
Power supply for external transmitters (300mA).

### Multifunction

Up to 4 control loops with advanced PID, self-tuned by the intelligent and interactive "InTune" algorithm. Logic and sequential as well as complex mathematic functions.

Historical and real time trends. Alarm handling, Auto/Man Station, variable monitoring, etc.

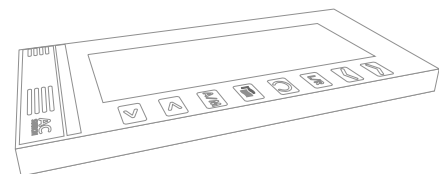
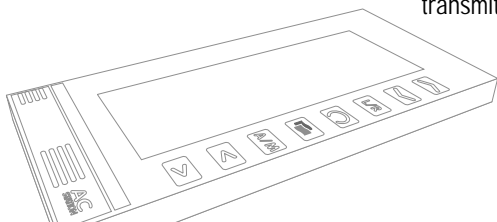

# The new challenge in control strategy

## Freely programmable

- Wide library of function blocks.
- The graphical, user-friendly AC-PROGRAPH software, running on a standard PC, lets you design the most suitable control strategy to match the requirements of any process.
- Programming can be carried out by the user with a guarantee of security and safety for the application.

## Easy to use

- There are 12 resident preprogrammed control strategies selectable from the keyboard.
- Remote tech-support.
- High resolution graphic panel displays in a simple, clear and complete manner:
  - interactive guided menus,
  - bargraph pages • trends,
  - alarms • commands.
- Three different levels of access for instrument programming, parametrization and normal operation.

## Very compact and light

- 172 x 144 DIN format
- Depth: 260mm.,
- Weight: 1.6 kg.

## From SLC to mini DCS

The extensive hardware, powerful software, and Peer to Peer communications, with associated simplicity of use, permit the application of the AC Station as a simple SLC, as a mini DCS, or as part of a DCS whenever it is integrated in a complex system.



## Guaranteed and Certified

Designed in accordance with IEC and EN standards, AC Station Controllers are available with CE, UL and C/UL approval.

AC Station Controllers are manufactured in accordance with ISO9001/EN9001 Quality Assurance Management System.

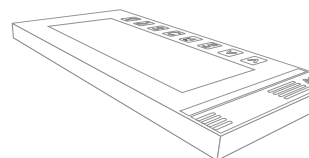
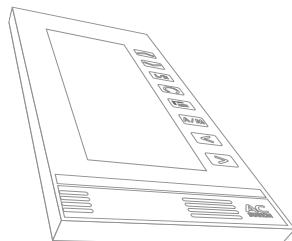
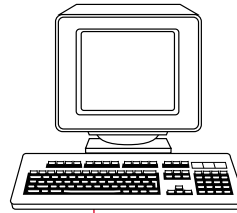

# The ultimate evolution in man-machine interface

## Display

Long life, clear, high resolution (128x320 pixels) LCD display. Size 40x104 mm. Extended operating temperature range (0-55°C) and adjustable contrast guarantee a high level of visibility even in harsh environments.

## Pages

Several pre-formatted pages are available to display numerical values, bargraphs, trends, alarms, menus. Designed to match a wide range of requirements, they can be customized.

## Menus

Self-explaining menus allow easy access to sub-menus and commands, structured hierarchically.

## Three operational levels

To simplify normal operations and to protect the most critical commands, the start-up engineer and the plant manager can set passwords to access different operational levels.

The programming of the control strategy can be done in a guided manner from the keyboard or with the help of a PC.

- Your Personal Process Information System
- Several pre-formatted "customizable" pages
- Easy to understand, guided, interactive menus
- Three levels of operation with differentiated access

## Auto-diagnosis

To test all the hardware resources, a complete diagnostic program

can be activated on the instrument, without the need of any external equipment.

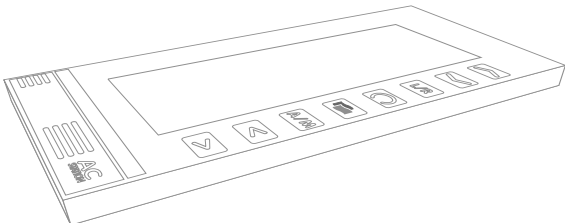

Input test

# The ultimate evolution in man-machine interface



Bargraph



Trend



Alarms



## Operator level

The **operator** can access bargraph, trend, alarm and command pages. In addition, depending on the entered password,

the **operator** can access permitted command and modification functions, such as Set point management and the Auto/Manual command.



## Project engineer level

The **project engineer** sets-up the control functions choosing from the standard preprogrammed strategies

or perhaps partially redesigning one of them. The **project engineer** can also build-up a completely new control strategy.

## Start-up level

The **start-up engineer** can access all the configuration parameters of the function and control blocks. The **start-up engineer** the also defines password and access codes for the operator.



Launching "In-Tune"



PID parameters...



Control Strategy selection



Function block menu



Function block selection

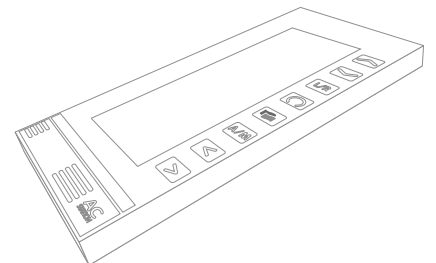

# The maximum freedom to design your own control strategy



Extensive library of elementary and complex function blocks  
 PC based programming software running under Microsoft Windows  
 Disk archiving of control strategies and parameters



**Display pages**  
 Bargraphs (1, 2, 3 or 4)  
 Trends  
 Alarms, logic status and signal forcings  
 Command panel  
 Programmer  
 Real-time clock  
 Guided and interactive menus  
 Parameters  
 Others, freely programmable

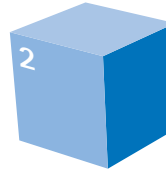

**Input conditioning**  
 Linearization Table  
 Polynomial linearization  
 Thermocouple output linearization  
 RTD output linearization  
 Scale changes  
 Engineering units  
 Square Root  
 Digital filter  
 Temperature compensation  
 Pressure compensation

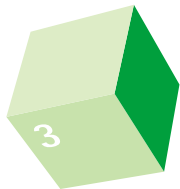

**Mathematical functions**  
 Addition - Subtraction  
 Multiplication - Division  
 Absolute value  
 Square Root  
 Power  
 Sine - Cosine  
 Exponential - Derivative  
 Nat.-Common logarithm



**Logic functions**  
 AND/OR/EXOR/NOT  
 Flip-flop  
 Select - deselect logic



**Complex expressions**  
 freely configurable  
 i.e. Koch's equation of state:

$$v = \frac{RT}{P} - \frac{A}{\left(\frac{T}{100}\right)^{2.82}} - p^2 \left[ \left(\frac{B}{100}\right)^{3.4} \cdot \left(\frac{C}{100}\right)^{31.4} \right]$$



**Comparators, selectors**  
 Max min selection  
 Limiter  
 Rate limiter  
 Analog - digital multiplexer

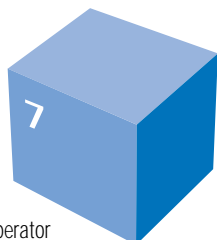

**Protection**  
 Different access  
 for project engineer ,  
 start-up engineer and operator  
 Set Point, Output, Input limits  
 Keyboard lock  
 Auto-diagnosis  
 Remote tech-support



# The maximum freedom to design your own control strategy



**Alarms**  
Absolute  
Deviation  
Rate



The AC Station Multifunction Controller provides an extensive library of analog and digital function blocks, from the very simple "AND / OR" module up to the very sophisticated Mathematics module capable of solving any level of complex functions.

This library is easy to use with **AC-PROGRAPH** graphic software running under Microsoft Windows™. With AC-PROGRAPH, a control strategy is built up by simply selecting, positioning, and configuring the function blocks on the worksheet, then drawing the required connections. This powerful software permits application of the AC Station Controller as a micro DCS. However, pre-configured standard strategies for the most common applications meet most requirements: These are supplied with the AC Station Controller and are selected from the instrument keyboard.

Function block configurations and all other controller parameters can be input via the front panel keyboard or downloaded from a PC. It is possible to upload them with a PC and store them on disk for archiving or for security purposes.



**Set point Management**  
Local-Remote,  
Safety Set point  
4 stored values  
4 priority levels



**Analog outputs**  
Min max Limits  
Rate limits  
Safety value  
Tracking  
Hold  
Min max signal forcings  
Heat/Cool outputs



**Control**  
Advanced PID algorithm with 2 degrees of freedom for a correct control response during both Set point and load changes.  
"InTune" Intelligent tuner  
Gain scheduling  
Bumpless  
Feed forward  
PID saturation signalling

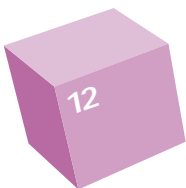
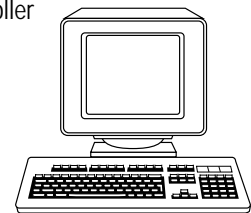

**Timers and counters**  
Totalizers  
Counters with reset  
4 types of timers  
Powerful scheduler



**Sequence**  
Up to 4 independent sequences  
16 x 4 selectable sequences  
Up to 100 steps per sequence

# New functions for advanced control

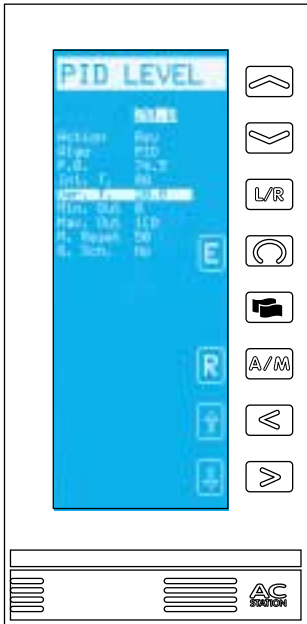

PID control algorithm with 2 degrees of freedom and gain scheduling

"InTune", an intelligent and interactive tuner

Complete, flexible and safe set point management

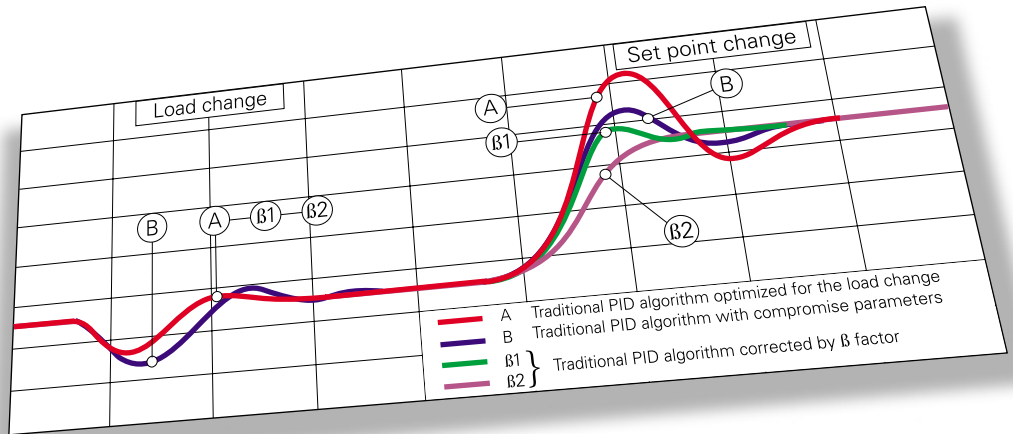

## PID algorithm with 2 degrees of freedom

Traditional PID control strategy is optimized for disturbances in the process. It does not respond in a satisfactory

manner to set point changes and vice-versa.

With the 2 degrees of freedom PID, it is not necessary to compromise either response: instead, the two responses are optimized

separately by a simple method, acting on a parameter (2nd degree of freedom).

## Gain scheduling

For process applications with nonlinear characteristics, or those strongly influenced by external factors, the gain scheduling function permits the modification of PID parameters to suit different operating conditions.

The gain scheduling rule can be defined in a tabular form or with a mathematical expression.

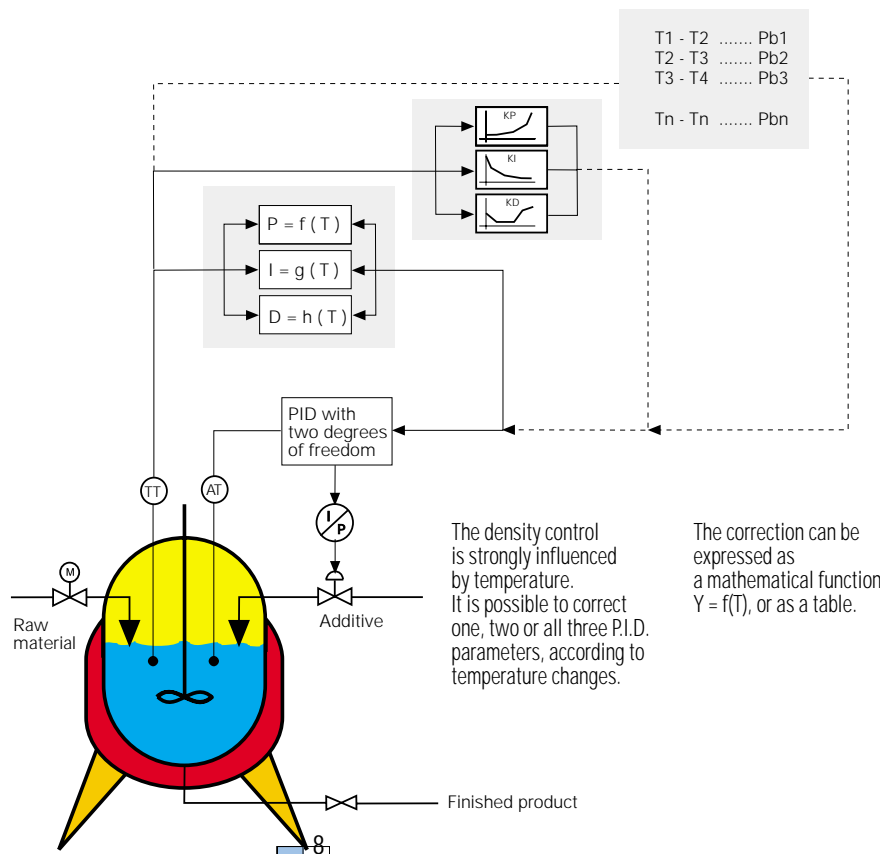

The density control is strongly influenced by temperature. It is possible to correct one, two or all three P.I.D. parameters, according to temperature changes.

The correction can be expressed as a mathematical function  $Y = f(T)$ , or as a table.

# New functions for advanced control

## "In Tune"

• **Intelligent:** "In Tune" uses the method known as "natural frequency" to calculate the control parameters on the basis of the selected algorithm (PID, PI, or P). Tuning can occur either at a set point change, or during process-steady conditions. With this method, small disturbances are introduced into the process by the controller. The response of the process is

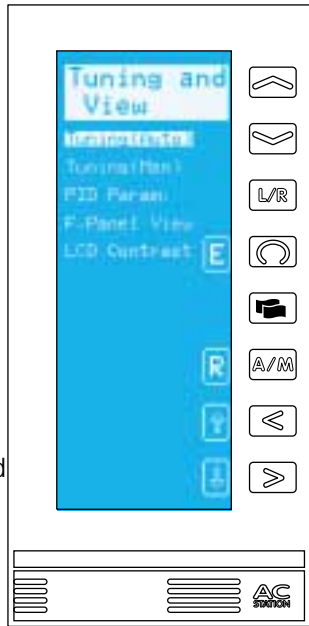

then analyzed and used to calculate the natural frequency of the process. The result is a big improvement over the conventional Ziegler and Nichols methods.

• **Interactive:** "In Tune" assists the operator by displaying the behavior of the process during the tuning phase and presenting, at the end of the procedure, the old parameters as well as

the new calculated ones. The operator can select between an automatic revision of the new parameter values, or a manual re-entry after approval.

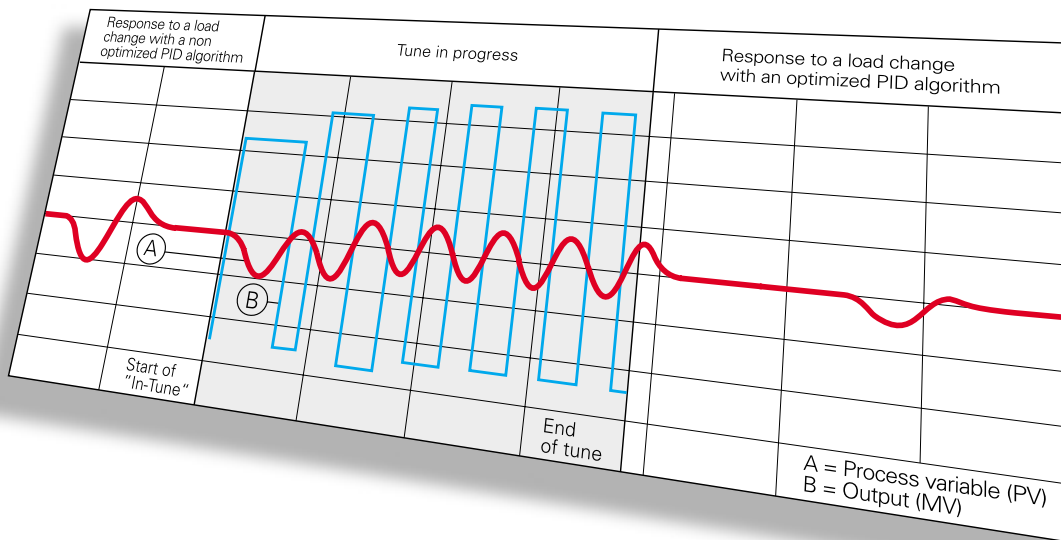

## Set point management

• **Complete.** In addition to the local set point entered through the instrument

keyboard, the following stored set point values are available: Analog Remote Set Point, Computer Remote

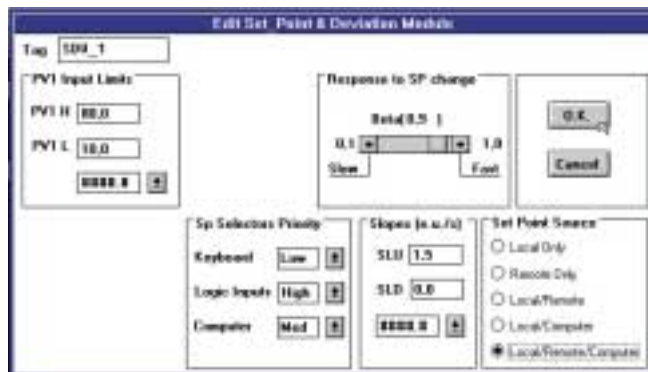

Set Point and Safety Set Point.

• **Flexible.** The working set point can be selected via the keyboard, internal logic, logic inputs or serial communications. The selection of the safety set point has the highest priority.

• **Safe.** Different levels of priority for the activation of the working set point can be assigned. This avoids conflict due to simultaneous requests, and eliminates the risk of unintended or unauthorized changes.



# Flexible integration via 4 communication ports



MODBUS/J-bus • RS485 MODBUS/J-bus • RS485 MODBUS/J-bus • RS485 MODBUS/J-bus • RS485 MODBUS/J-bus



EXPANSION • I/O EXPANSION • I/O EXPANSION

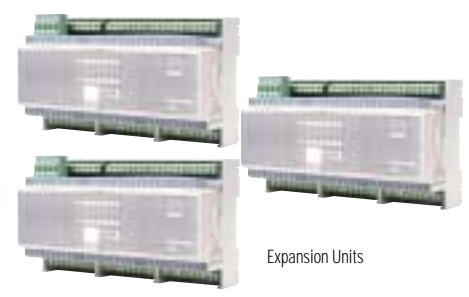

PEER • PEER TO PEER • PEER TO PEER • PEER TO PEER • PEER TO PEER • PEER TO PEER

**RS485 Port for Expansion Units**  
 AC20 and AC30 controllers support the connection of up to 3 expansion units to increase the number of I/O channels.

Analog output can be increased from 4 to 8, and digital I/Os from 8 to 32 channels.

**Peer-to-Peer communications**  
 This port, available as an option for AC20 and AC30 controllers, enables sharing of hardware and software resources among a set of instruments,

to build up a small distributed integrated system (mini DCS). Supervisory functions can still be provided using RS485 Communications Port.

# AC10 Multifunction Multiloop Controller

Up to 4 Independent loops

4 analog inputs + 4 analog outputs

8 digital inputs + 8 digital outputs

RS485 serial link with Modbus / J-bus protocol

12 preprogrammed control strategies selectable via the frontal keyboard

Within the family of AC Station controllers, the AC10 model represents the ideal solution for many common control problems such as single and multiple loops, ratio, cascade, etc.

## Hardware

The AC10 Controller is equipped with :

- 4 analog inputs for variables to be controlled, recorded or monitored.
- 4 analog outputs for control and/or retransmission.
- 8 opto-isolated digital inputs:
  - enable remote, safety or stored set points
  - force manual operating mode
  - activate special functions such as tracking, bias, or feedforward, etc.
- 8 opto-isolated digital outputs for commands and/or alarms.

## Communications

- RS485 serial port with Modbus and J-bus protocols permits connection to a PC for supervision, parametrization and remote-tech support.
- RS232 serial port permits, through the PC, the downloading, uploading and saving of parameters.



## Control strategy

Description	PID	Set Rem	Set Mem	F.F.	Tracking Int.	Ext.	MAN	Ysaf.	Ymin	Ymax	Analogue. Retransm	Alarms
1 Loop A	1	1	1	-	1	-	1	-	-	-	1	4
1 Loop B	1	1	3	1	1	1	1	-	1	1	3	8
1 Loop C	2	1	3	-	1	1	1	-	1	1	2	6
2 Loops A	1+1	1+1	1+1	-	1+1	-	1+1	1+1	-	-	1+1	4+4
2 Loops B	1+1	1	1+1	1	1+1	-	1+1	1+1	1	1	2	4+4
2 Loops C	2+1	1	1+1	-	1+1	1	1	-	1	1	1	6+2
Ratio	2	1+1	1	-	1+1	-	1+1	1+1	1	1	-	7+1
Cascade	2	1	1	-	1+1	-	1	-	-	-	1+1	4+4
Override	2	1+1	1+1	-	1	-	1	1	1	1	1+1	5+3
4 Loops	4	-	-	-	1x4	-	1x4	1x4	-	-	-	2x4
4 Indicators	-	-	-	-	-	-	-	-	-	-	1x4	2x4
A/M Station	-	-	-	-	2	2	2	2	2	2	2	-

# AC10 Multifunction Multiloop Controller

## Interface and Programming

Thanks to an easy to understand, guided and interactive menu, the user interface (GUI) is very easy, clear and safe. All the functions and displays are activated in a simple manner using the keys on the front panel. One of the most important characteristics of this controller is the availability of a library with 12 preprogrammed Control Strategies (CS) stored in its memory (see table). After lecting the required Control Strategy, by means of simple and guided operations on the front panel, the instrument presents only the related configuration parameters.

Offering exceptional adaptability, the **AC10 Controller** is the ideal choice to meet the frequently changing control requirements of many industrial process applications from food to

chemical/pharmaceutical industry, from power generation to environmental control, from glass to cement industry, etc.

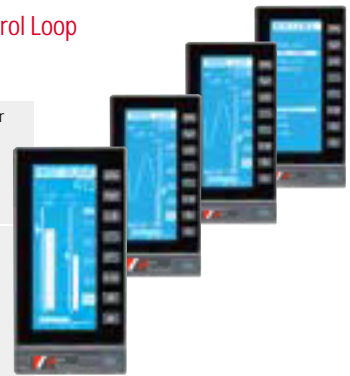
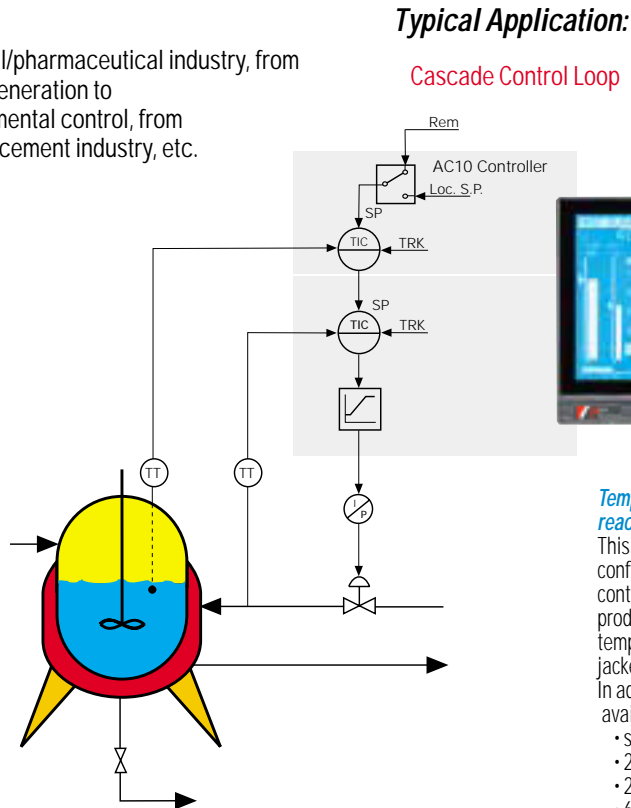

### Temperature control of chemical reactor

This application requires a **cascade** configuration with the master loop controlling the temperature of the product and the slave loop controlling the temperature of the heating fluid in the jacket.

In addition, the following functions are available:

- selection of Loc/Rem Set Point,
- 2 analog retransmissions,
- 2 trackings, the output limiters,
- 6 alarms and signal forcings.

## Typical Application:

### 4 Independent Loops

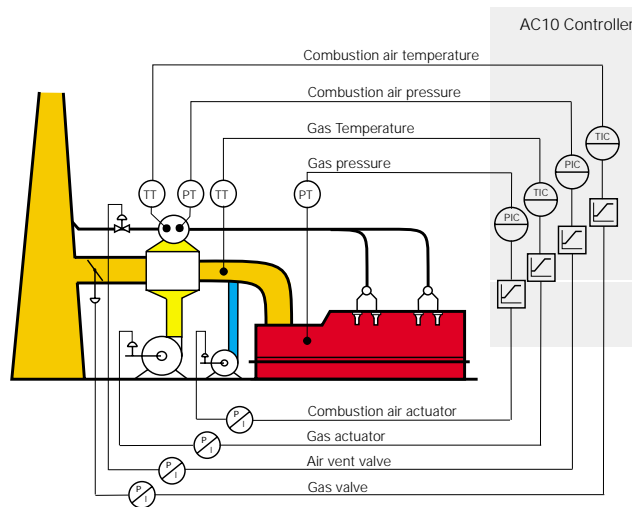

### Combustion Control of a Heating Furnace

This application requires 4 independent controllers for combustion air pressure, combustion air temperature, pressure of the flue gases, and recuperator input flue gas temperature.

In addition the following functions are available:  
4 trend displays, 4 limits on the outputs, 8 alarms and 4 signal forcings.



# AC 20 Freely Programmable Mini DCS

- Up to 8 analog inputs + 8 analog outputs
- Up to 32 digital inputs + 32 digital outputs
- RS485 with Modbus and J-bus protocol
- Peer-to-Peer communications
- Multiple resident control strategies
- Extensive library of function blocks for programming with a PC

The extensive and expandable hardware, the 4 communications ports, and especially the complete freedom in programming Control Strategies, make the **AC20** an advanced and powerful controller, suitable for **every** process, even the most complex.

## Expandable hardware

The **basic AC 20 Controller**

is equipped with:

- 8 analog inputs,
- 4 analog outputs,
- 8 opto-isolated digital inputs
- 8 opto-isolated digital outputs

## External Expansion Units

connected to the basic **AC 20** add:

- 4 analog outputs,
- 24 digital inputs,
- 24 digital outputs.

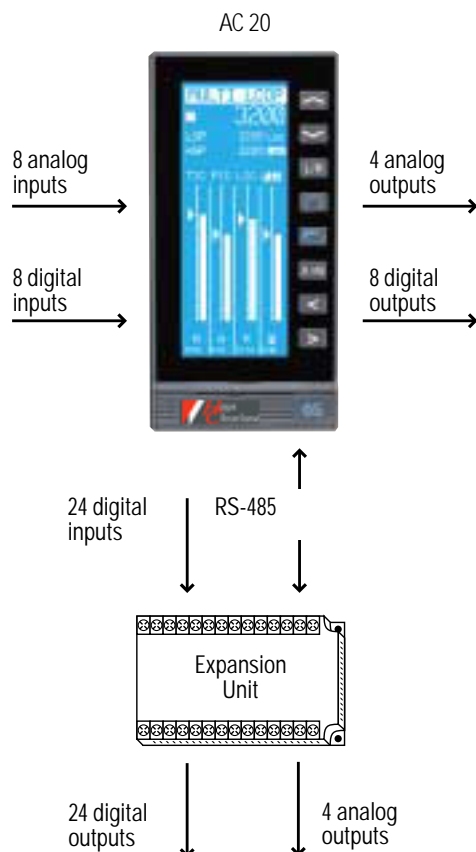

# AC 20 Freely Programmable Mini DCS

## Communications

In addition to the Modbus and J-bus RS485 serial port for SCADA, and the RS232 programming port, the **AC20** is equipped with:

- a **second** RS485 port for the connection of the expansion units
- a port for Peer-to-Peer LAN intended to build up a true mini DCS (see pages 9-10).

## Programming

The required Control Strategy can be selected using the keys on the front panel, or it can be freely programmed with a PC and the AC-PROGRAPH software package running under Microsoft Windows. This software allows

- Programming of a control strategy in a simple, guided manner, by picking the required function blocks from a library (see page 5 and 6),
- Drawing soft-wiring (as in a CAD program).

A library of typical Control Strategies can be built up and stored on the disk of a PC, to be reused later, either as they are, or with appropriate modifications for other, similar applications.

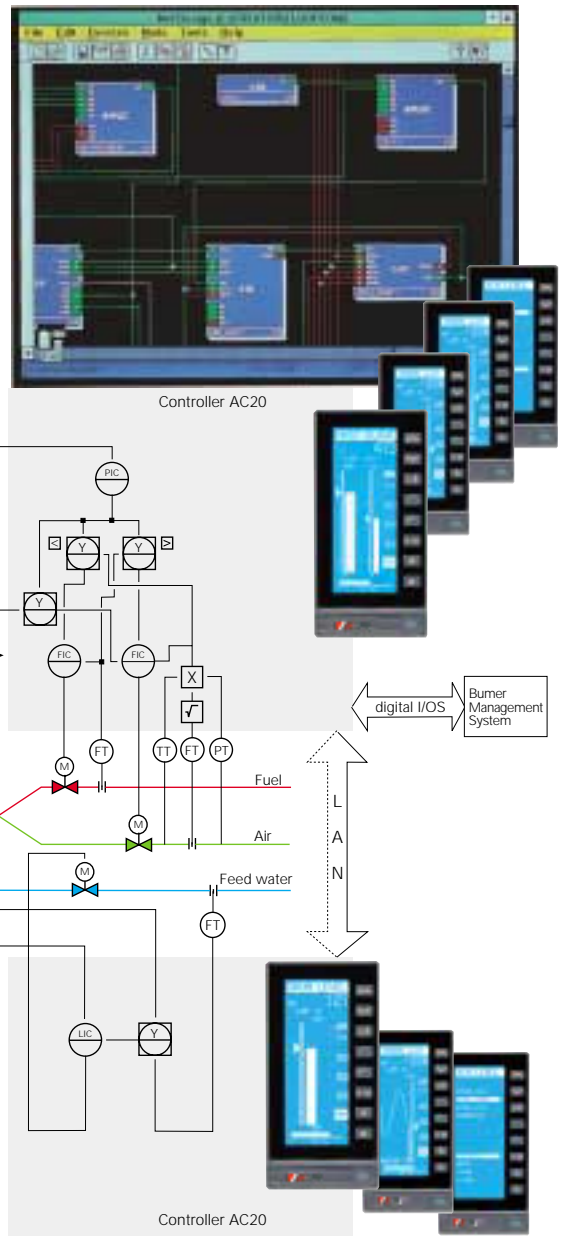

**Complete control of a boiler with only two AC20 controllers**  
 The **first** AC20 controller provides the combustion control, along with the anti-smoke system and oxygen trim. Mass flow of combustion air is computed. The **second** AC20 controller provides three element drum level control. Other functions may include dual fuels and superheater control.



# AC 30 Controller Programmer for continuous and batch processes

Up to 4 synchronized or independent programs / sequences

64 configurable and selectable programs / sequences

Up to 400 segments / steps totally

Powerful activity scheduler based on real time clock

While retaining the main hardware and software characteristics of AC 20 (I/O channels, control functions, full-programmability and digital communications), **AC 30** better fits the particular needs of batch process control.

**Setpoint profile generation** and, more generally, **sequence handling** allow easy management of many applications: heat treatments, chemical reactions, environmental controls, crystal growing and material testing are typical examples.

## Program / sequence

Up to 4 programmers / sequencers can be simultaneously activated: each module can generate a setpoint profile with ramps and dwells and, in addition, can produce an auxiliary setpoint value and up to 16 digital commands (on - off) for each segment / step. Each programmer / sequencer provides the following commands: Start, Halt, Next Step, Fast (for a fast execution of the sequence) and Reset.

It is possible to configure automatic interlocks in case of significant deviation of process variables from ideal setpoint profiles. Programs can be repeated automatically several or infinite times. Thanks to the user friendly graphical interface, normal operations and set-up functions can be accessed very easily.

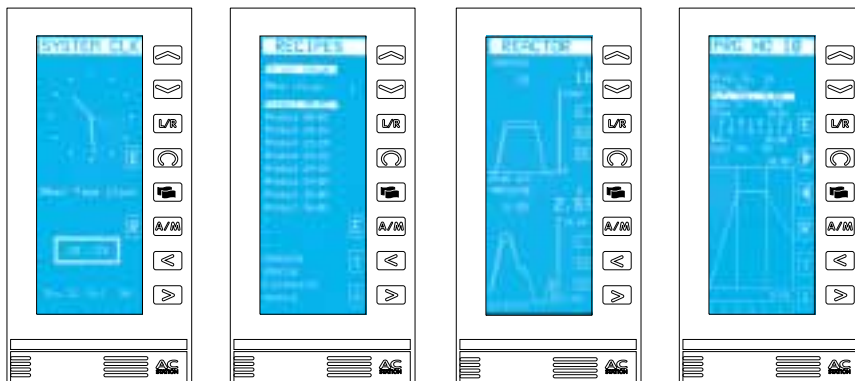

# AC 30 Controller Programmer for continuous and batch processes

## Real time clock

Batch process handling often requires automatic activation of operations in the plant or on the auxiliary equipment. To solve this problem, **AC 30** provides a real time clock that is easily configured to generate up to 56 events in a week. The clock is battery backed-up and runs case of main power failure: this allows the configuration of safety logic for warm and cold restart in accordance with process dynamics.

## Diagnostics and safety

**AC 30** can measure significant deviations of the controlled variables from the configured setpoint profiles, and detect short- or long-term power failures. In response to these conditions, **AC 30** automatically activates logic routines designed to assure the safety of the staff and to prevent equipment or product damage. These include:

- warm restart
- restart from the previous step
- hold
- program / sequence reset

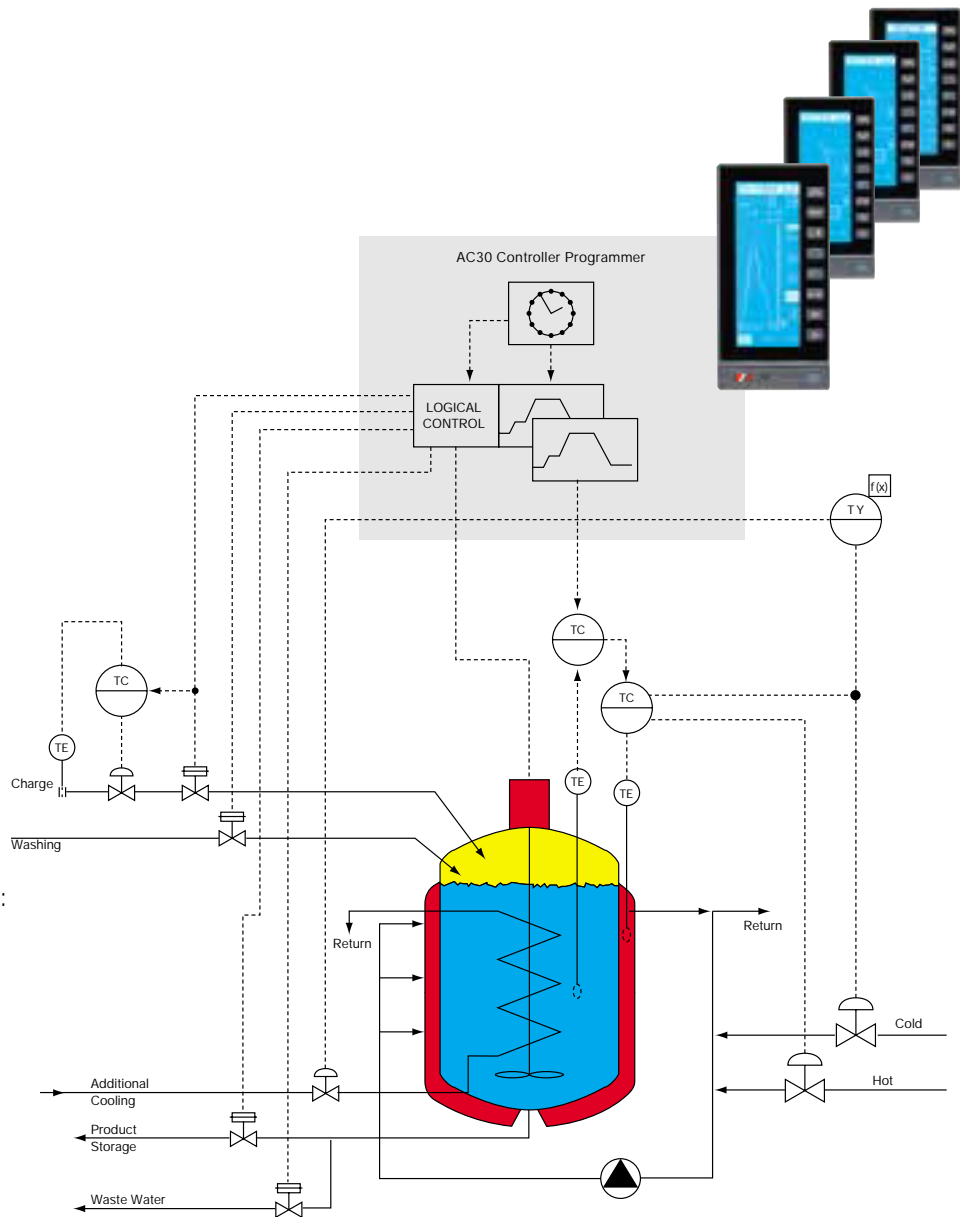

## Reactor control

A single AC 30 can control the following phases:

- Ingredients loading, in accordance with preset quantities.
- Parameter control of the reaction in accordance with preset values and times. Several control strategies are available: for example,

**cascade control** is used in processes with long lags, and the **heat/cool algorithm** is required to control exothermic reactions.

- Activation of commands such as stirrer start/stop, circulation pumps, etc.
- Product discharge and storage.
- Washing cycle.

Furthermore several recipes for multi-product reactors can be stored and activated manually or automatically.

# Auxiliary Units

Expansion of I/O channels

Remote I/O handling

Signal conditioning

Simplification of wiring with sensors and actuators

A complete and homogeneous series of DIN rail mounting expansion units simplifies field signal wiring and increases the number of I/O channels.

## Expansion Units

Each unit is equipped with a RS 485 communications line and permits expansion of the number of I/O channels of AC 20 and AC 30 models. Connected to the expansion port of the controller, they can be mounted

at a distance of up to 1200 meters, often reducing cabling costs. Up to 3 Expansion Units can be connected in multidrop to each controller.

2 models are available with the following characteristics:

- **EU/88**  
8 digital input + 8 digital output
- **EU/88/4**  
8 digital input + 8 digital output + 4 analog output (max 1 unit).



# Technical Data

<b>AC STATION</b>		<b>AC10</b>	<b>AC20</b>	<b>AC30</b>
<b>Inputs and Outputs</b>				
Analog inputs	1...5Vdc/0...5 Vdc, (impedance >10M $\Omega$ ) - 4...20mA/0...20mA (with external shunt) Accuracy 0.1%, resolution 16 Bit	4	8	8
Digital inputs	Passive opto-isolated. Voltage: On 8...36 Vdc, Off 0...1.5 Vdc Frequency input. Configurable range 200 Hz, 2kHz, 20kHz	8	8-32*	8-32*
Analogue outputs	Galvanically isolated from the inputs. 1...5 V dc/0...5 Vdc; 4...20mA/0...20mA (su 500 $\Omega$ ) - Resolution 13 Bit	4	4-8*	4-8*
Digital outputs	Opto-isolated, solid state relay. Max load: 300 mA e 30 Vdc/Vac. Protected with auto-reset fuses	8	8-32*	8-32*
Expansion Unit	For the addition of: 4 analog outputs, 24 digital inputs, 24 digital outputs	-	0	0
<b>Control Functions</b>				
Cycle time	0.1-10 sec., adjustable.	●	●	●
PID management	1...4 independent loops Advanced PID algorithm, two degrees of freedom type with feedforward gain-scheduling. Advanced "In Tune", natural frequency type.	●	●	●
Control strategies	Resident and preprogrammed Preprogrammed and available on disk Freely programmable with PC and AC-PROGRAPH	12	12	12
Sequence	Max number of active Sequence Modules Max steps per Sequence Module Max stored Sequences per Module Analog output per Sequence Module Digital output per Sequence Module	-	-	4 100 16 2 16
Real Time Clock	Hardware with battery backup Events on a weekly basis Max number of events	-	-	● ● 56
<b>Communications</b>				
RS 232 port	Configuration and Programming	●	●	●
RS 485 port	ModBus and J-bus protocols (slave)	●	●	●
RS 485 port	I/O Expansion Units	-	0	0
2.5 Mb/s Network	Peer-to-peer Communication	-	0	0
<b>Physical and Environmental</b>				
Weight	max 1700 g.	●	●	●
Front Panel Protection	IP 54	●	●	●
Supply Voltage	12 Vac 50/60 Hz	●	●	●
Power Consumption	20 VA max	●	●	●
Auxiliary Supply	24 Vdc/max 300mA for field transmitters	●	●	●
Electromagnetic Compatibility	EN 55011, EN 50081-2, EN 50082-2	●	●	●
Operating Conditions	KWF for DIN 40040	●	●	●
Operating Temperature	0 to 50C	●	●	●
Storage Temperature	-20 to +60C	●	●	●
Humidity	10...90% non-condensing	●	●	●

\* With inner Expansion Unit ● standard ○ option - not available

## Dimensions (compliant to the DIN 43700 standard)

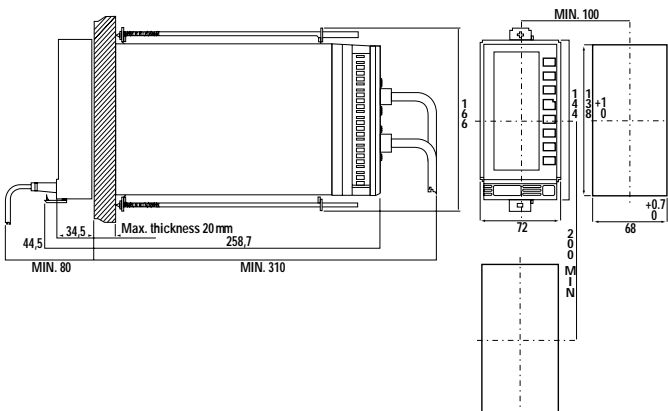

<b>Expansion Units</b>		<b>EU/88</b>	<b>EU/88/4</b>
<b>Hardware</b>			
Mechanical	DIN rail mounting	DIN 6 105 mm	DIN 9 157.5 mm
Serial port	RS 485	1	1
Voltage Supply/Consumption	11 Vac 50/60 Hz	9 VA max	11 VA max
Power Supply Transformer	220/240 Vac, 32 VA max		
<b>Inputs and Outputs</b>			
Digital inputs	Opto-isolated Free voltage contact	8	8
Digital outputs	Relay (220V 3A)	8	8
Analog outputs	4-20 mA	-	4

## Ordering codes

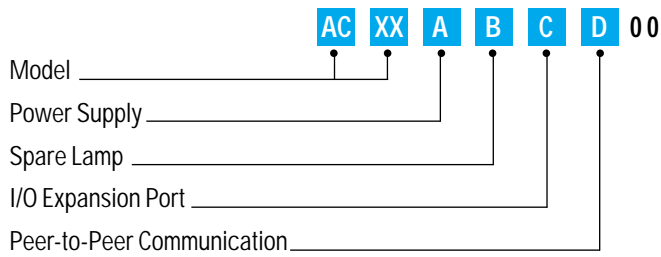

Model	XX
DIN 72x144 mm, 260 mm depth	10
DIN 72x144 mm, 260 mm depth	20
DIN 72x144 mm, 260 mm depth	30
Power Supply	A
100...240V, 50/60 Hz	3
18...28 V, 50/60 Hz o 20...30 Vdc	5
Spare Lamp (option)	B
None	0
Included	1
Expansion Units Port (option) [1]	C
None	0
Included	1
Peer-to-peer Communication (option) [1]	D
None	0
Included	1

[1] = Not available for AC10

### Auxiliary Units

AAC-EU/88	Expansion Unit 8 dig/in + 8 dig/out
AAC-EU/88/4	Expansion Unit 8 dig/in + 8 dig/out + 4 an/out
AAC-TA	Power Supply for up to 3 Expansion Units



### Sales Offices

**1111 Brookpark Road  
Cleveland OH 44109**

**Tel: 216.398.4414**

**Fax: 216.398.8558**

**1903 S. Congress Ave.**

**Boynton Beach FL 33436**

**Tel: 561.734.9400**

**Fax: 561.734.8060**

**email: [salescombustion@unicontrolinc.com](mailto:salescombustion@unicontrolinc.com)**

**website: [www.hayscleveland.com](http://www.hayscleveland.com)**

Distributed by: