

LINEAR ACTUATOR

FEATURES & BENEFITS

- Compact, flexible design is suitable for combustion and process control applications.
- Stepping motor stops and starts instantaneously: eliminates coast and provides precision positioning.
- High starting torque overcomes static friction.
- Impedance-protected motor is not damaged if overload stalling occurs.
- Standard 6" range of travel.
- 30, 60, and 120 second nominal stroke times.
- 75, 150, and 300 lb. thrust ranges. Equivalent to 18.75, 37.5, and 75.0 ft. lbs.
- Operates on switched line voltage input.
- Optional handwheel.
- Optional feedback potentiometer for remote position indication.
- Optional adjustable "safe start" position switches.
- Available NEMA 3 (weather-resistant) housing.
- Linkage: clevis and shaft lever arm, spring link for tight closed valve applications.

INTRODUCTION

Hays Cleveland Series 9140 Linear Actuators offer long life, safety, reliable operation, and easy maintenance. These compact units are available with a full range of options for maximum flexibility in any combustion control or process control application.

Series **9140 Linear Actuators** accept electrical line voltage signals from a switched output controller to position a final control element, such as a damper, control valve, louver, stoker lever, variable speed transmission, or any similar device, over a six-inch range of travel.

Optional features are available to suit any combustion control or process control application. These include adjustable starting position switches, an isolated auxiliary end-of-travel switch, weather-resistant housing, handwheel, and an externally or internally generated position feedback signal.

Hays Cleveland Series 9140 Linear Actuators require no mechanical brake assembly. The inherent braking-action of the synchronous stepping motor prevents overtravel without the wear and stress associated with friction or "DC" braking. As shown in the **Specifications** section of this bulletin, three stroke times and thrust ranges are offered for all models.



For special stroke time/thrust requirements, please consult your local **Hays Cleveland** representative. For convenient comparison with competing rotary actuators, this bulletin provides equivalent torque ratings (in foot-pounds) for the thrust ratings of these linear motion actuators. The torque ratings are valid for a 3" lever traveling through a 90° arc.

GENERAL OPERATIONS

The line voltage signals control the reversible motor in finite increments to drive an acme screw through a nonslip timing belt drive and pulley system. The screw drives through a travel nut-and-bearing arrangement to extend or retract the drive tube. The nut and screw assembly self-locks in the case of power failure, in order to maintain final drive tube position.

End switches shut off power to the motor when the unit reaches either the inward or the outward travel extreme.

All applications use the full six-inch travel of the drive arm. Linear or nonlinear movement of the final control element, as well as its total range of travel, is controlled by adjustment of the linkage connecting the actuator's drive arm to the operating lever of the final control element. Overload stalling will not damage the motor.

Hays Cleveland Series 9140 Linear Actuators can be mounted in any position on any flat, rigid surface free from excessive vibration. All wiring connections are easily accessible for maintenance. The ambient temperature limit is 140F (60C).

A full range of linkage components and accessories is available. For applications where remote position indication is desired, an optional feedback potentiometer (135Ω, 1000Ω, or 4000Ω) is available. For high-performance electronic draft control applications, optional "Adjustable Start" position switches are available to allow preset damper positioning during burner pilot ignition.

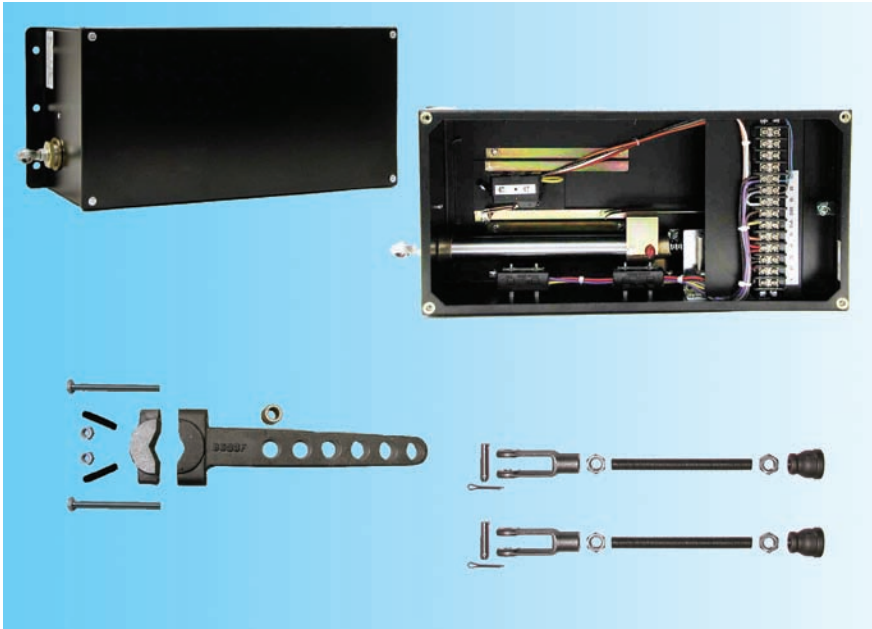

LINKAGE

The following linkage items (sold separately) are available for use with the **Series 9140 Electric Linear Actuator**:

P/N 11372 Damper Lever Arm: A two-piece aluminum alloy casting, with bushing, bolts, and nuts. Adjusts for 1/2 to 1 1/2" shafts.

P/N 26908 Clevis Assembly: A clevis yoke and pin with a threaded adjusting rod, reducing coupling, and 2 1/2 - 20 hex nuts.

P/N 12677 Spring Link (not shown): Provides tight closure for valve applications.

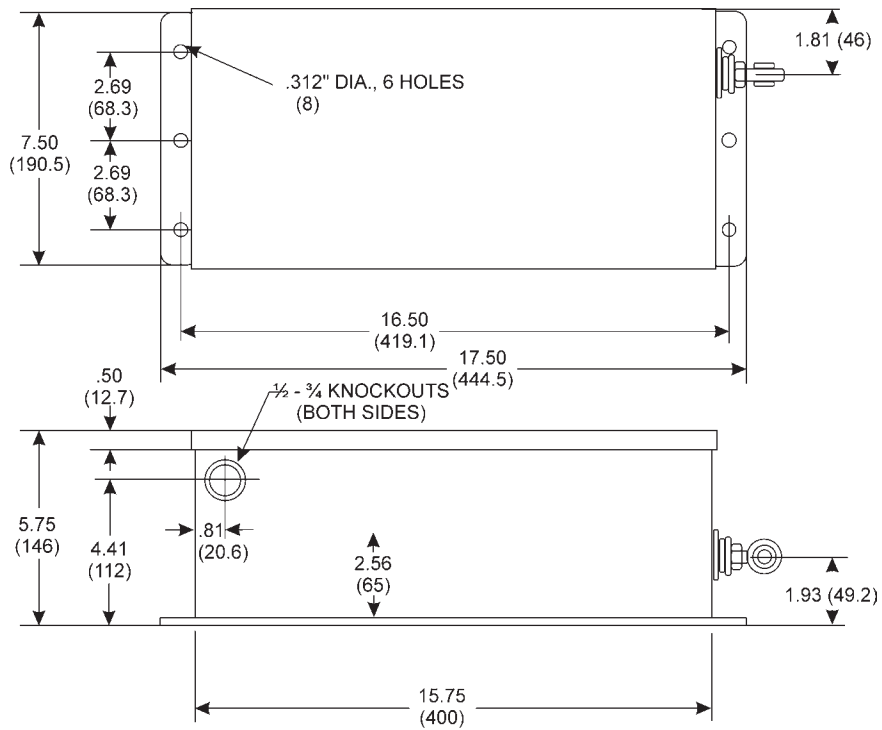
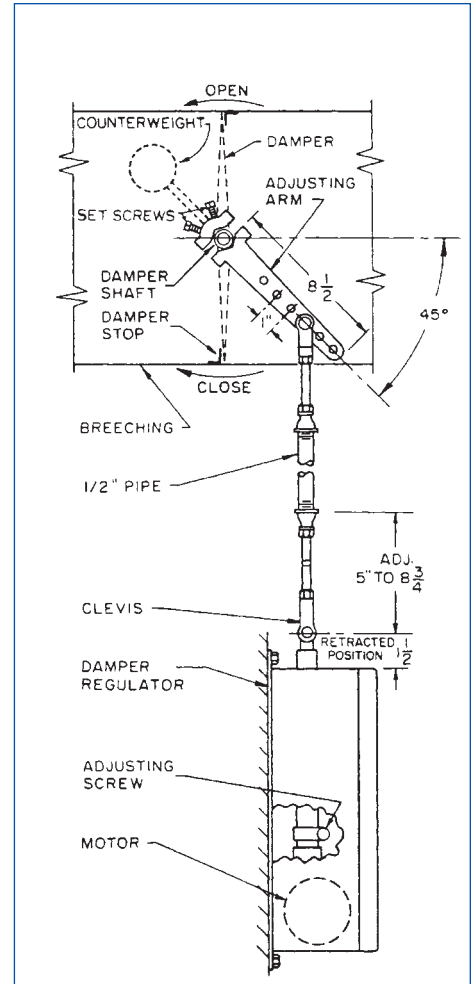

SERIES F-09140 LINEAR ACTUATOR

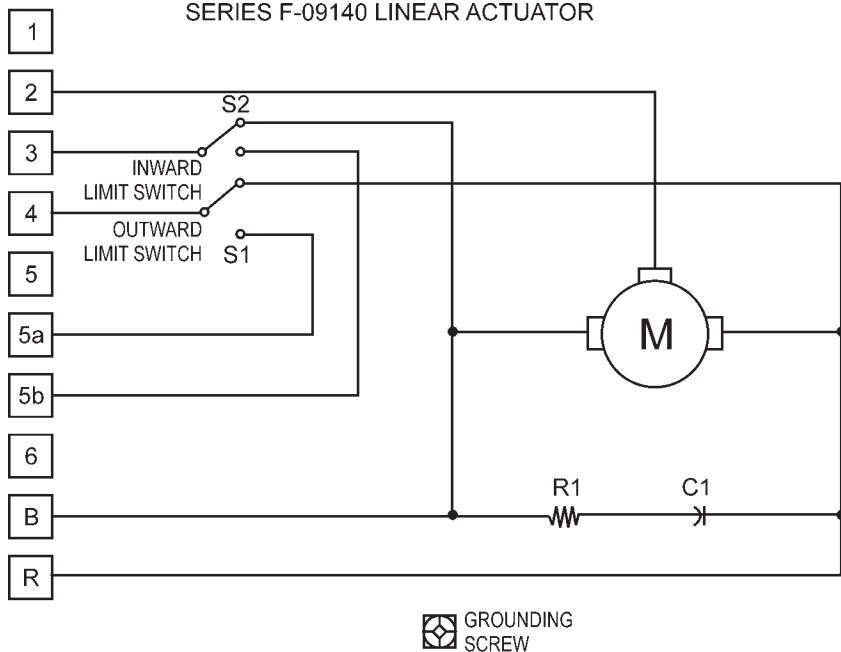

SERIES F-09140 LINEAR ACTUATOR WITH ADJUSTABLE START POSITION SWITCHES

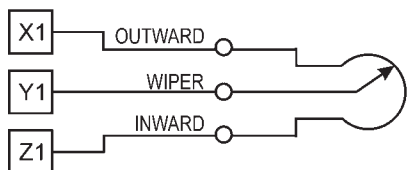
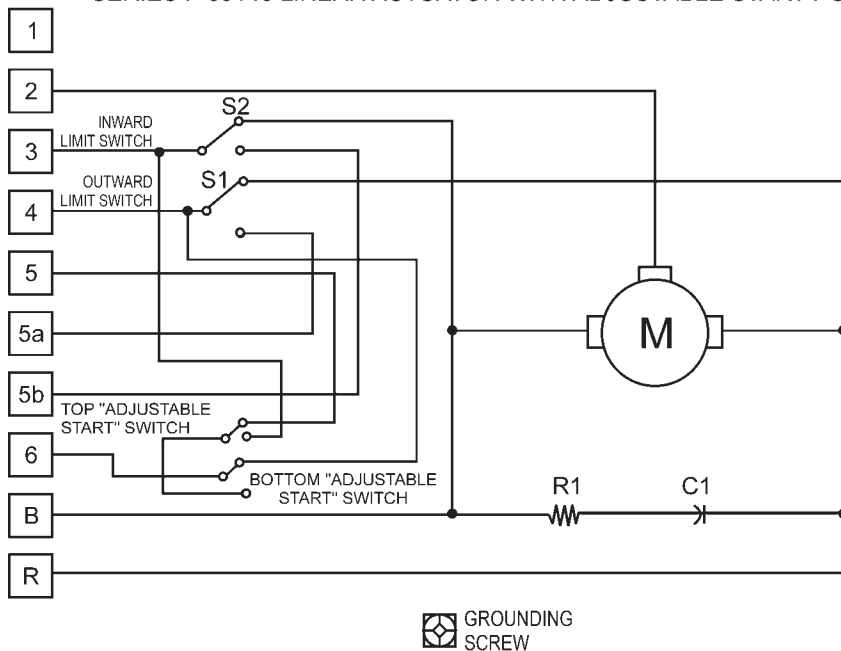

Feedback Potentiometer (Optional)

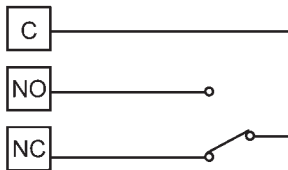

Isolated Auxiliary End of Travel Switch (Optional)

NOTES:

1. When outward stroke opens the damper, jumper terminals 5 and 5a.
2. When inward stroke opens the damper, jumper terminals 5 and 5b.
3. To reverse operation, interchange external wires to terminals 3 & 4 and (if used) X1 & Z1.
4. External wiring: Use wire suitable for 167F (75C).
5. Input rating: 120 Vac, 60 Hz., 25 VA max.

HOW TO ORDER

The basic catalog number for the Hays Cleveland Series F-09140 Linear Actuator is shown below. Replace suffixes A through F with the desired selections from the table below.

F-0914A-BCD-E-F

A. Nominal Stroke Time/ Thrust Range:

- A1=30 seconds/75 lbs. thrust (18.75 ft. lbs.)
- A2=60 seconds/150 lbs. thrust (37.5 ft. lbs.)
- A3=120 seconds/300 lbs. thrust (75.0 ft. lbs.)

B. Position Feedback Potentiometer:

- B0=None
- B1=1000Ω
- B2=4000Ω
- B3=135Ω

C. Custom Positioning Options:

- C=0 None
- C=1 Adjustable Start Position Switches
- C=2 Isolated Auxiliary End-of-Travel Switch

D. Custom Housing Options:

- D=0 None
- D=1 Handwheel (Continuous Rotation Type)
- D=2 NEMA 3 Rated (Weather-Resistant)

E. Power Requirements:

- E=1 120 v AC 50/60 Hz.
- E=2 240 v AC 50/60 Hz.

F. Current Model Designation: A

SPECIFICATIONS

PHYSICAL

Power Requirements: 120 v AC or 240 v AC, 50/60 Hz.

Case Dimensions: 15.75" long x 7.5" wide x 5.75" high.

Mounting: Any position.

Motor: Commercially available 72 RPM stepping motor operated in synchronous mode.

Input Signal: Switched line voltage input.

Wiring Connections: Screw-type terminals for power to motor and for all alarm and control connections.

Ambient Temperature: 0 to 140F (-19 to 60C).

Case Material: Hinged, dust-tight and drip-proof; NEMA 3 units are gasketed as required.

Finish: Wear-resistant sealed black polyurethane enamel.

Shipping Weight: 35 lbs.

APPLICATION

Travel: Six-inch linear travel.

Stroke Time: 30, 60, or 120 seconds per 6" of travel at 60 Hz.

Thrust: 75, 150, or 300 lbs. (Equivalent to 18.75, 37.5, and 75 foot-pounds with a 3" lever arm.)

Positioning accuracy: +/- 0.25%.

End Switches: High and low end limit snap switches are standard.

Adjustable "Safe Start" position switches or an isolated auxiliary end of travel switch are optional.

Handwheel: Continuous rotation type (optional).

Feedback Potentiometer: Optional. 1000Ω, 4000Ω and 135Ω available.

PERFORMANCE

Resolution:

- 30-second speed: 0.50% of full stroke.
- 60-second speed: 0.25% of full stroke.
- 120-second speed: 0.12% of full stroke.

Deadband: <0.2% of full stroke.

Radial Load Limit: Linkage axis not to exceed 15° deflection from drive tube axis.

Expected Service Life: 15 years at 70% duty cycle and 70% rated load.

DISTRIBUTED BY:

Visit us on the World Wide Web at www.hayscleveland.com

Hays Cleveland Div. of UniControl Inc.
1903 South Congress Avenue
Boynton Beach FL 33426
Telephone: 561.734.9400
Fax: 561.734.8060
e-mail: salescombustion@unicontrolinc.com

Hays Cleveland Div. of UniControl Inc.
1111 Brookpark Road
Cleveland OH 44109
Telephone: 216.398.4414
Fax: 216.398.8558
e-mail: salescombustion@unicontrolinc.com

Are you reading a FAX or a COPY of this bulletin? DOWNLOAD the full-color PDF version of this and other literature at our website!