

Model F-09160-A0

LINEAR ACTUATOR

(with Analog Input Circuitry)

THE HAYS CLEVELAND SERIES 9160 IS A COMPACT, VERSATILE LINEAR ACTUATOR WITH OPTIONS SUITABLE FOR ANY CLOSED OR OPEN LOOP APPLICATIONS.

FEATURES

- **Compact, Flexible Design is Suitable for Any Combustion or Process Control Application**
- **Stepping Motor Stops and Starts Instantaneously to Eliminate Coast and Provide Precision Positioning**
- **High Starting Torque Overcomes Static Friction**
- **Impedance-Protected Motor is Not Damaged if Overload Stalling Occurs**
- **30, 60, and 120-Second Nominal Stroke Times**
- **75, 150, and 300 lb. Thrust Ranges (Equivalent to 18.75, 37.5, and 75.0 ft. lbs.)**
- **Optional Handwheel**
- **Auxiliary Position Switches (“Extended” and “Retracted”) are Standard**
- **Optional Second Auxiliary Switch for “Retracted” Position is Available**
- **Digital Filtering Minimizes Unnecessary Control Action That Can Result From Noise**



APPLICATION

The Hays Cleveland Series 9160 LINEAR ACTUATORS offer long life, safety, reliable operation, and easy maintenance. These compact units are available with a full range of options for maximum flexibility in any combustion control or process control application.

Series 9160 LINEAR ACTUATORS accept 4-20 ma or 1-5 v DC control signals to position a final control element such as a damper, control valve, louver, stoker lever, variable speed transmission, or any similar device over a six-inch range of travel.

Optional features are available to suit any combustion control or process control application. These include an adjustable starting position switch, a second auxiliary switch for the retracted arm position, weather-resistant housing, handwheel, and an externally or internally generated position feedback signal.

The Hays Cleveland Series 9160 LINEAR ACTUATOR requires no mechanical brake assembly. The inherent braking-action of the synchronous stepping motor prevents overtravel without the wear and stress associated with friction or “DC” braking. As shown in the *Specifications* section of this bulletin, three stroke times and thrust ranges are offered for all models. For special stroke time/thrust requirements, please consult your local Hays Cleveland technical representative. For convenient comparison with competing rotary actuators, this bulletin provides equivalent torque ratings (in foot-pounds) for the thrust ratings of these linear motion actuators. The torque ratings are valid for a 3" lever traveling through a 90° arc.

GENERAL OPERATIONS

A self-contained pulse drive controller converts a 4-20 ma DC or 1-5 v DC control signal to switched 120 v AC line voltage that controls a reversible motor in finite increments to drive an acme screw through a nonslip timing belt drive and pulley system.

The screw drives through a travel nut and bearing arrangement to extend or retract the drive tube. The nut and screw assembly self-locks in the case of power failure, in order to maintain final drive tube position.

End switches shut off power to the motor when the unit reaches either the inward or the outward travel extreme. Typically, an internal potentiometer in the actuator is used to provide position feedback to the positioner circuit; as an input option, external 1-5 v DC or 4-20 ma DC feedback devices (not included with the actuator) may be used. All applications use the full six-inch travel of the drive arm. Linear or nonlinear movement of the final control element, as well as its total range of travel, is controlled by adjustment of the linkage connecting the actuator's drive arm to the operating lever of the final control element. Overload stalling will not damage the motor.

As standard features, "retracted" and "extended" auxiliary switches are provided to operate lights or other ancillary equipment as required for customer use. In addition, the actuator can be equipped with **one optional switch**: either a second "retracted" position auxiliary end switch or an "Adjustable Start" position auxiliary switch.

The Hays Cleveland Series 9160 LINEAR ACTUATORS can be mounted in any position on any flat, rigid surface free from excessive vibration. All wiring connections are easily accessible for maintenance. The ambient temperature limit is 140 degrees Fahrenheit (60 degrees Celsius). A full range of linkage components and accessories is available.

PULSE-DRIVE CONTROL

The modulating capabilities of the electric actuator are a result of its **self-contained pulse-drive controller**. A 1-5 v DC or 4-20 ma DC command signal from an external controller or station is fed directly into the pulse-drive controller inside the actuator

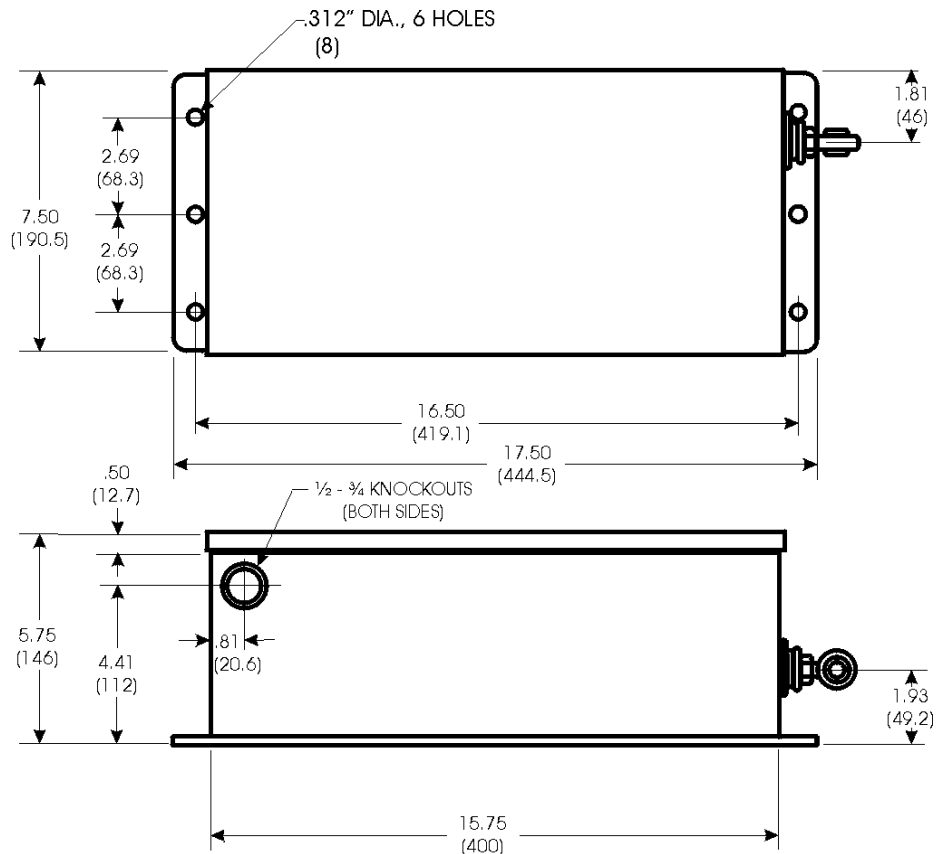

enclosure. The controller compares the command signal to a position feedback signal generated from an internal position potentiometer (or external feedback device). The deviation, or "error," between these two signals is used to generate **time-proportioning, integral pulse control action** for the actuator drive motor.

As the actuator moves toward the desired command position, the control action shifts from a continuous control action range to a proportional pulse "width" (duration) range wherein the actuation decelerates from decreasing "on"-time pulse width until the final command position is reached.

DEAD BAND: As long as the deviation, defined as the algebraic difference between the command signal and the position feedback signal, is within an adjustable "dead band," no control action is generated.

PROPORTIONAL BAND: The "proportional band" lies immediately outside of either end of the dead band. Whenever the deviation exceeds the

pre-selected proportional band, the controller generates **continuous** control action, and the motor drives the actuator continuously in either the extended or the retracted direction.

Once the deviation falls within the adjustable proportional band, the controller signal changes to pulse mode. In **pulse mode**, the controller generates intermittent pulses of control action to smoothly position the actuator. The "**period**," or on-time plus off-time pulse cycle, is adjustable (0.1 to 4.0 seconds). As the actuator moves through the proportional band toward the final command position, processing circuitry reduces the **duration** of the pulse signal from 100% to 0% of the period. A "minimum step" adjustment is provided to establish a minimum pulse duration to ensure effective actuation based upon anticipated load conditions. Digital filtering minimizes unnecessary control action resulting from "noisy" signals. The precise, responsive control action provides superior stability and eliminates overshoot.

External Wiring Table Terminal Block # 1

Terminal Point	Description
1	Modulation Enable; 120 v AC
2	Common
3	Drive Motor Decrease (Retract); 120 v AC Hot
4	Drive Motor Increase (Extend) 120 v AC Hot
7	Retracted Position Auxiliary Switch; Common
8	Retracted Position Auxiliary Switch; Normally Open
11	Extended Position Auxiliary Switch; Common
12	Extended Position Auxiliary Switch; Normally Open
B	(No Field Wiring)
R	(No Field Wiring)
13	Internal Positioner Decrease (Retract) Signal: To be jumpered to Terminal Point 3 directly or through external manual/auto switch, as required.
14	Internal Positioner Increase (Extend) Signal: To be jumpered to Terminal Point 4 directly or through external manual/auto switch, as required.
"_"	4-20 ma DC Command Signal Input (or 1-5 v DC Command Signal Input).
"+"	4-20 ma DC Command Signal Input (or 1-5 v DC Command Signal Input).

Figure 1: P/N 28113 Positioner Card with Potentiometric Input

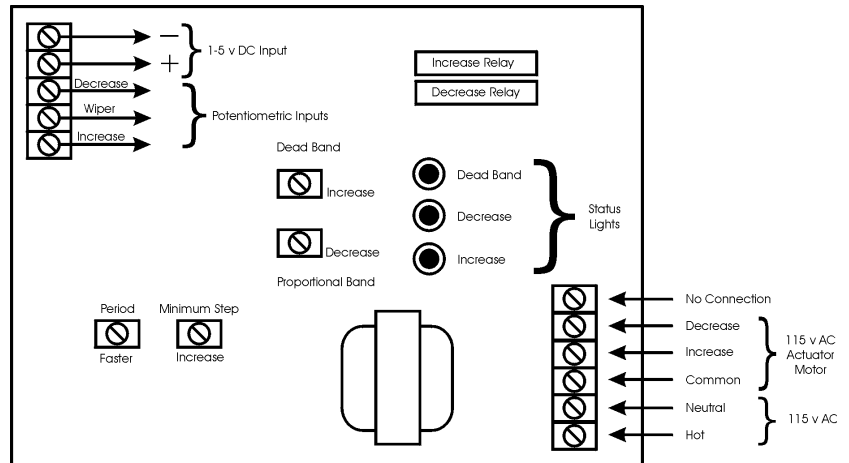

Specifications for Positioner PC Boards:

P/N 28113 (With Potentiometric Input) and P/N 30314 (With Dual 1-5 Volt Inputs)

Power: 115 v AC, 3 va, 50/60 Hz., 1 Ph.

Input: 1-5 volts, nominal.

Input # 2 (P/N 30314): 1-5 volts, nominal.

Position Feedback Potentiometer (P/N 28113): 1K ohms to 10K ohms.

Output Drive: Solid state, zero switched.

- **Voltage:** 115/230 v AC.
- **Load Current Minimum:** 60 ma.
- **Load Current Maximum:** 2 amp at 30°C (Derate to 1 amp at 75°C).
- **Over Current:** Maximum (non-repetitive) –7 A pk for 1 second.
- **Surge Current:** Maximum (non-repetitive) –28 A pk for 20 ms.
- **Off-Stage Leakage Current:** Maximum 8 ma.

Indicators:

- **Increase:** Green LED.
- **Decrease:** Green LED.
- **Dead Band:** Red LED.

Adjustments:

- **Dead Band:** 0 to ± 3% (6% of total) of the 6-inch travel of the actuator drive tube.
- **Proportional Band:** ± 2% to ± 25% of the 6-inch travel of the actuator drive tube.
- **Period:** 0.1 second to 4.0 seconds.
- **Minimum Step:** 0 to 20% of period.

Figure 2: P/N 30314 Positioner Card with Dual 1-5 v DC Inputs

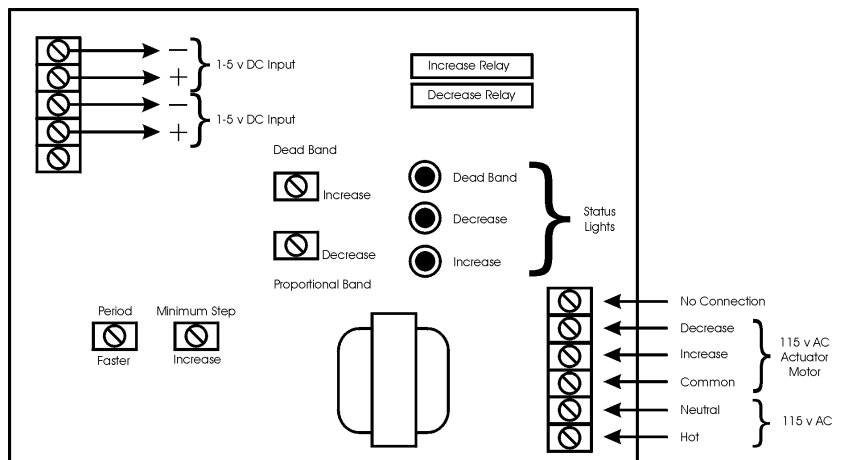

HOW TO ORDER

The basic catalog number for the **Hays Cleveland Series 9160 LINEAR ACTUATOR (With Analog Input Circuitry)** is shown below. Replace suffixes A through H with the desired selections from the table below.

916A-BCDE-FG-H

A. Nominal Stroke Time/ Thrust Range:

- 30 seconds/75 lbs. thrust [18.75 ft. lbs.] (-A01)
- 60 seconds/150 lbs. thrust [37.5 ft. lbs.] (-A02)
- 120 seconds/300 lbs. thrust [75.0 ft. lbs.] (-A03)

B. Optional Switches:

- None (-B00)
- Adjustable Starting Switches (-B01)
- Second "Retracted" Position Switch (-B02)

C. Manual Operator:

- None (-C00)
- Handwheel (-C01)

D. Other Options:

- None (-D00)
- Auxiliary Feedback Potentiometer (-D01)

E. Power Requirements:

- 120 v AC 50/60 Hz. (-E01)
- 240 v AC 50/60 Hz. (-E02)

F. Input Options (Command Signal/ Position Feedback Signal):

- 4-20 ma / Internal Potentiometer (-F01)
- 1-5 v DC / Internal Potentiometer (-F02)
- 1-5 v DC / External 1-5 v DC (-F03)
- 4-20 ma / External 4-20 ma (-F04)
- 1-5 v DC / External 4-20 ma (-F05)
- 4-20 ma / External 1-5 v DC (-F06)

G. Enclosure:

- NEMA 1A (-G01)
- NEMA 3 (-G02)

H. Current Model Designation: A

In addition, the following accessories and related products may be necessary.

LINKAGE

P/N 26908 Clevis Assembly:

Consists of 1 Clevis Yoke and Pin, 1 Threaded Adjusting Rod, 1 Reducing Coupling, and 2 Hex Head Nuts, ½ - 20.

P/N 11372 Damper Lever Arm:

Consists of a 2-piece aluminum alloy casting, with bushing, bolts, and nuts. Adjustable for ½ to 1 ½ " shafts.

P/N 12677 Spring Link: Provides overtravel and tight closure for valve applications.

SPECIFICATIONS

PHYSICAL

Power Requirements: 120/240 v AC, 50/60 Hz.

Case Dimensions: 15.75" long x 7.5" wide x 5.75" high.

Mounting: Any position.

Motor: Commercially available stepping motor operated in synchronous mode.

Input Signal: 4-20 ma DC or 1-5 v DC.

Wiring Connections: Numbered terminals for power to motor, and for alarm and control connections.

Ambient Temperature: 0 to 140F (-19 to 60C).

Finish: Wear-resistant sealed black polyurethane enamel.

Shipping Weight: 35 lbs.

APPLICATION

Travel: Six-inch linear travel.

Stroke Time: 30, 60, or 120 seconds.

Thrust: 75, 150, or 300 lbs. (Equivalent to 18.75, 37.5, and 75 foot-pounds with a 3" lever arm.)

Positioning accuracy: ± 0.25%.

End Switches: "Retracted" and "Extended" position switches are standard. One additional "Retracted" or one "Adjustable" switch is available.

Handwheel: Continuous rotation type (optional).

Feedback Potentiometer: Optional; 1000 ohm (standard), 4000 ohm and 135 ohm also available.

Specifications Subject to Change.



Visit us on the World Wide Web at www.hayscleveland.com

Hays Cleveland Div. of UniControl Inc.
1903 South Congress Avenue
Boynton Beach FL 33426
Telephone: 561.734.9400
Fax: 561.734.8060
Email: salescombustion@unicontrolinc.com

Hays Cleveland Div. of UniControl Inc.
1111 Brookpark Road
Cleveland OH 44109
Telephone: 216.398.4414
Fax: 216.398.8558
Email: salescombustion@unicontrolinc.com