



## Instruction Manual

for

P/N 3500086

Filter Replacement Kit

&

P/N 3500087

Cell/Heater/RTD Replacement Kit

used with

Series A-10007 and A-10018 Oxygen Analyzers



### WARNING

Do not operate or service this equipment before reading the operator's manual! Failure to do so could result in serious injury.



Alterations to hardware, wiring, or software must be approved in writing by Hays Cleveland, Division of UniControl Inc.





Instruction Manual  
for  
P/N 3500086  
Filter Replacement Kit  
&  
P/N 3500087  
Cell/Heater/RTD Replacement Kit

used with  
Series A-10007 and A-10018 Oxygen Analyzers

**NOTE:**  
DO NOT RE-USE ANY HARDWARE IN THE PROBE ASSEMBLY.  
NEW HARDWARE IS SUPPLIED WITH EACH KIT.

## CONTACT INFORMATION

Hays Cleveland  
Division of UniControl Inc.  
1111 Brookpark Rd.  
Cleveland OH 44109

Customer Service:

**Tel. 216.398.4414 • Fax 216.398.8558**

**Sales Office:**

**Tel. 561.734.9400 • Fax 561.734.8060**

<http://www.hayscleveland.com>

---

## **SAFETY WARNINGS**

(Safety symbols and terminology per ANSI Z21.)

Failure to comply in full with the following safety requirements can result in equipment damage and personal injury/death.

1. Read the entire manual to become familiar with the use and operation of this device.
2. Only qualified personnel should attempt to install, wire, commission, startup, service or operate this device.
3. This device is not suitable for use in an explosive ambient atmosphere.
4. Before working on this device, be sure that you understand the processes affected by this device completely.
5. Before working on this device, be sure that any process affected by this device is secure and safe for servicing.
6. Take appropriate precautions to avoid electric shock when working with this device near water.
7. Exercise caution while wiring or working on this device. Multiple voltage sources may be present: take appropriate precautions to avoid electric shock.

## P/N 3500086 Filter Replacement Kit

The ceramic filter protects the sensor from particulate matter in the process. It may be cleaned periodically using an ultra-sound cleaner. In severe environments replacement is necessary if the filter is badly plugged or eroded. See **Figure 1**, "Test for a plugged filter". Follow the steps below to remove the old filter for replacement or cleaning.

1. Remove the oxygen analyzer probe as follows.
  - 1.1. Disconnect AC power before removing the electrical connector to avoid damaging the heater circuits.
  - 1.2. Remove the plug-in connector by opening the spring clips and pulling the connector away. Note: to avoid damage to the connector bundle, do not twist.
  - 1.3. Cover the electrical connector using a clean cloth or plastic bag to protect from dirt, dust, grease, and water.
  - 1.4. Wear high temperature protective gloves. Even if

the flue is cool, the sensor end of the probe will be extremely hot.

- 1.5. Remove all eight 5/8" flange-mounting bolts. Do not drop the probe. Most of the weight is in the mounting flange. Protect the sensor/filter end as you remove it.
- 1.6. Slide the probe out of the breeching flange. Do not crush the calibration tube or dent the probe body tube.
2. Remove the old filter as follows.
  - 2.1. Remove and discard the 1/4-20 nuts attaching the filter deflector and filter to the sensor-end flange or flame arrester housing.
  - 2.2. Lift away the old filter.
3. Clean for re-assembly as follows.
  - 3.1. Remove all old gasket materials, soot fly ash, or other debris from the filter gasket seating area. This is important so that the new filter and gasket fit tightly with no leakage.

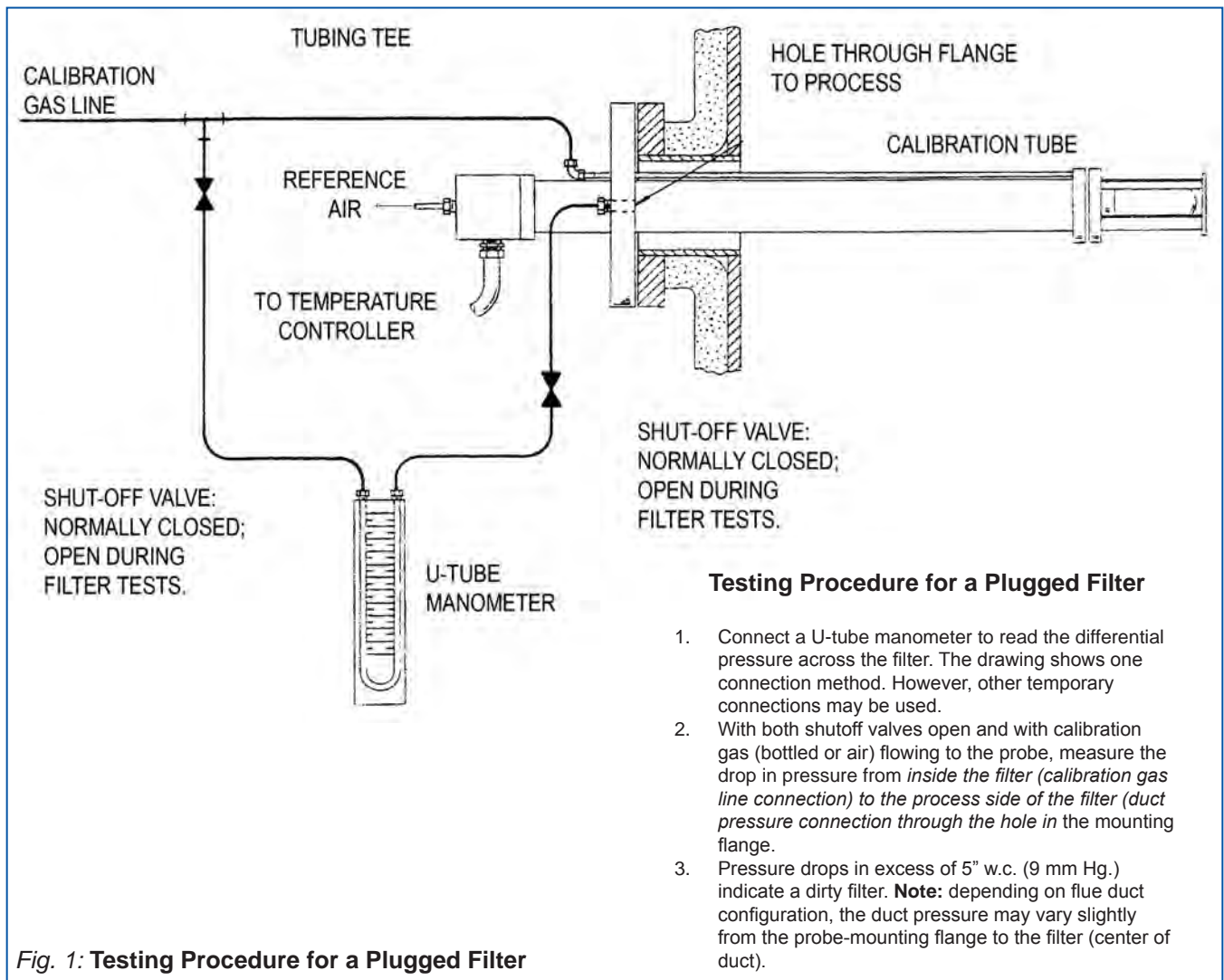


Fig. 1: Testing Procedure for a Plugged Filter

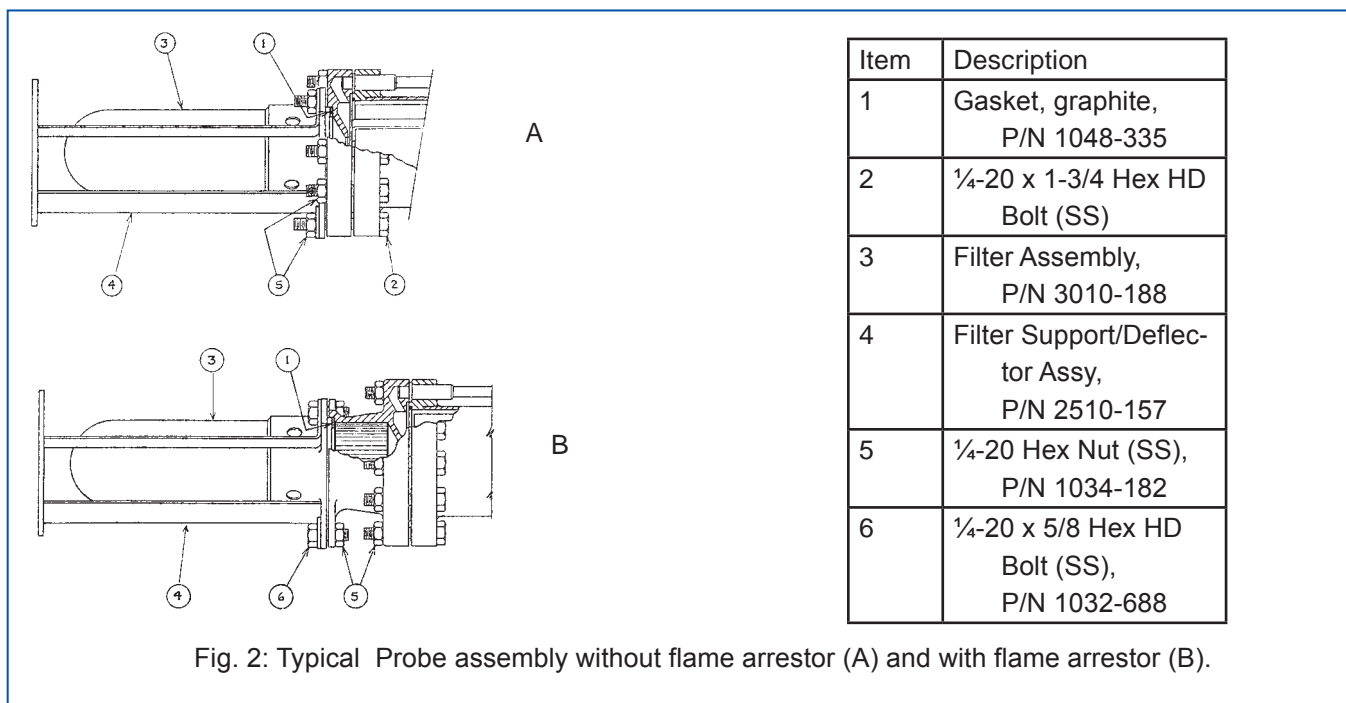
### Testing Procedure for a Plugged Filter

1. Connect a U-tube manometer to read the differential pressure across the filter. The drawing shows one connection method. However, other temporary connections may be used.
2. With both shutoff valves open and with calibration gas (bottled or air) flowing to the probe, measure the drop in pressure from *inside the filter* (calibration gas line connection) to the process side of the filter (duct pressure connection through the hole in the mounting flange).
3. Pressure drops in excess of 5" w.c. (9 mm Hg.) indicate a dirty filter. **Note:** depending on flue duct configuration, the duct pressure may vary slightly from the probe-mounting flange to the filter (center of duct).

- 3.2. If a flame arrestor is installed and it is clogged, blow instrument air into the calibration tube to clear it. Use a stiff brush to dislodge foreign material from the open end of the flame arrestor.
- 3.3. If there is no flame arrestor, the inside of the cell may contain debris. Allow the cell to cool to room temperature (one to two hours). Gently, using a clean soft brush, cloth, or paper towel, wipe away any dry foreign material from the inside of the cell. Be careful not to scrub or remove any of the light gray (platinum) areas in and near the bottom of the cell. A cotton swab moistened with distilled or de-ionized water can be used to dissolve deposits that will not wipe out otherwise. Dry the cell thoroughly before proceeding. Do not leave any oily deposits (from hands, cloths, etc.) inside the cell.
4. Install the replacement filter on models without flame arrestors as follows. Skip to step 5 for models with flame arrestors.
  - 4.1. Install the graphite filter gasket (Item 1 in **Figure 2A**).
  - 4.2. Install three new mounting bolts (Item 2 in **Figure 2A**). These 1/4-20 by 1-3/4" long bolts extend outward from the probe as shown. Lubricate the threads with anti-gall lubricant.
  - 4.3. Mount the filter assembly (Item 3 in **Figure 2A**). Tabs on the body of the casting mount over the three mounting bolts.
  - 4.4. Mount the filter support/deflector (Item 4 in **Figure 2A**) over the tabs on the filter body casting.
  - 4.5. Attach new holding bolts and "finger-tighten" the

nuts (Item 5 in **Figure 2A**). Visually check for even seating. Torque all eight nuts to 20 inch-pounds (2.3 Nm), then to 50 inch-pounds (5.6 Nm), and finally up to 85 inch-pounds (9.6 Nm). Important: refer to **Figure 16** for the torquing pattern: rotate around the flange tightening every third nut until all are at 20 inch-pounds. Then repeat for 50 and 85 inch-pounds. Damage to the filter casting can occur if bolts are tightened all the way at once.

5. Install the replacement filter on models with flame arrestors as follows.
  - 5.1. Install the graphite filter gasket (Item 1 in **Figure 2B**).
  - 5.2. Assemble the filter assembly (Item 3 in ) into the filter support/deflector assembly (Item 4 in **Figure 2B**). The three sets of mounting holes will line up.
  - 5.3. Align with the flame arrestor housing. Assemble with three 1/4-20 by 5/8" long bolts (Item 6 in **Figure 2B**). Lubricate the threads with anti-gall lubricant.
  - 5.4. Attach new holding bolts and "finger-tighten" the nuts (Item 5 in **Figure 2B**). Visually check for even seating. Torque all eight nuts to 20 inch-pounds (2.3 Nm), then to 50 inch-pounds (5.6 Nm), and finally up to 85 inch-pounds (9.6 Nm). Important: refer to **Figure 16** for the torquing pattern: rotate around the flange tightening every third nut until all are at 20 inch-pounds. Then repeat for 50 and 85 inch-pounds. Damage to the filter casting can occur if bolts are tightened all the way at once.



---

## 6. Reinstall the oxygen analyzer probe

- 6.1. Determine the direction of the flue gas flow.
- 6.2. Use a 1/16"-thick ring gasket (P/N 1048-336A) between the probe mounting flange and the installation flange when remounting the oxygen analyzer probe.
- 6.3. Install the probe so that the filter deflector vane is directed into the flue gas flow. Misalignment of the filter deflector vane and the flue can damage or plug the filter due to particulates in the flue gas.
- 6.4. Tighten all eight nuts and bolts on the mounting flange. See **Figure 16** for the correct torquing pattern. Reconnect the electrical connector assembly. Make sure the connector is free of dirt and dust.
- 6.5. Apply AC line power and allow thirty minutes for warm-up.
- 6.6. Calibrate according to instructions in the oxygen analyzer manual. Calibrate again after 48 hours to eliminate the minor drifting that can occur after cleaning or replacing components.

---

## P/N 3500087 Cell/Heater/RTD Replacement Kit

The following instructions cover cell, heater, and RTD replacement. Refer to **Figure 17** for parts identification.

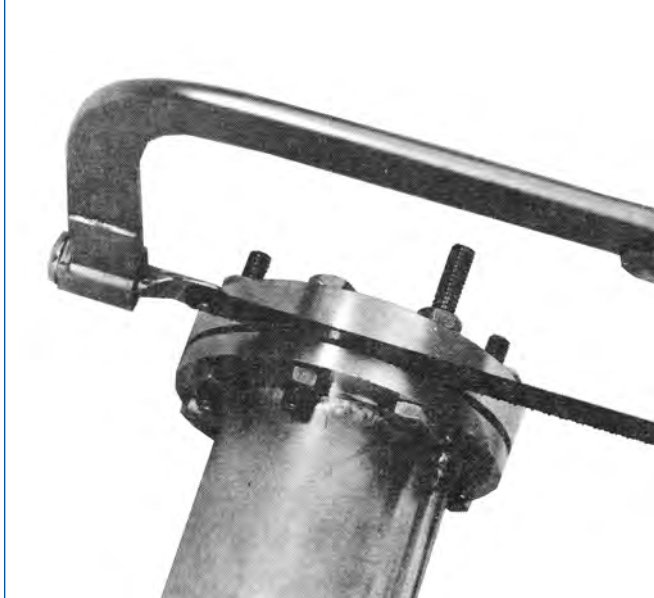
1. Remove the probe from the stack following the steps in section 1 on page 2 of this bulletin.
  - 1.1. Take the probe to a service area that is free from dust and dirt, and securely block it to prevent rolling. Support the filter end so that it does not contact the working surface.
  - 1.2. For models without flame arrestors, remove the filter deflector and filter by removing the three ¼ -20 nuts (Item 8) and bolts (Item 19).
  - 1.3. Do not damage the filter: it can be cleaned and reused if it is not plugged.
  - 1.4. Remove the filter gasket (Item 10) seated in the flange. If it is in good condition, save it for reuse.
  - 1.5. For models with flame arrestors, it is not necessary to disassemble the filter deflector (Item 9), filter (Item 12), flame arrestor (Item 23), and flame arrestor housing (Item 22). Proceed to the next step.
  - 1.6. For all models, remove the filter and flame arrestor as a unit along with the sensor mounting flange by removing all eight bolts (Items 7 and 19). Use two 7/16" wrenches if the threads are undamaged. Saw frozen bolts as shown in **Figure 3**. Do not cut the calibration tube by sawing as shown in **Figure 4**.
  - 1.7. Remove the connector bundle assembly (Item 2).
  - 1.8. Push on a reference gas tube. With fingers or palm, push the reference tube from the back in order to push the cell assembly out the front of the probe. It should slide out easily. Do not hammer. See **Figure 5**.
  - 1.9. Pull out the sensor assembly. Extend the sensor assembly enough so that the terminal and mounting screws are accessible for easy removal. (Or you may remove the sensor assembly connector bundle completely. See **Figure 6**.)
2. Remove the sensor assembly from the lead bundle as follows.
  - 2.1. To identify the terminals for reassembly, see **Figure 7** for the lead terminal numbers.
  - 2.2. Six 6-32 x 7/8 SS screws hold the sensor leads. Hold the ring terminals to prevent twisting during removal. Avoid damaging the leads if they are to be reused.
- 2.3. Remove the three sensor-mounting screws and special self-locking nuts. Use an internal hex wrench and an open-end or box wrench to dismount the cell mounting legs.
3. The Inconel O-ring (Item 6) must be replaced whenever the eight bolts of the sensor-mounting flange are loosened or removed. Remove this disposable metal O-ring as follows.
  - 3.1. Do not insert any sharp tools between the O-ring and the flange weldment. This could damage the seating surface of the flange, preventing leak-tight sealing when reassembled.
  - 3.2. Slide the connector bundle down into the probe body or remove it entirely to avoid damaging the ceramic spacers.
  - 3.3. Set a 1/8" diameter flat-faced punch (drift punch) on the outside diameter of the metal O-ring and tap it with a hammer. Deform the O-ring inwards (toward the center). Grab it with your fingers to remove it.
4. If replacing the complete cell/heater/RTD assembly, skip down to step 7. If replacing individual components, continue with step 4 as follows.
  - 4.1. For disassembly of the cell/heater/RTD assembly, see **Figure 8**.
  - 4.2. Remove the cell insulation packing that holds the RTD in position. Be careful not to damage the leads. Keep the packing clean, dry, and free of metal shavings. See **Figure 9**.
  - 4.3. Remove the RTD (Item 4). See **Figure 10**. Gently pull the legs close to the tabs so that they spread outward just enough to clear the heater can with the tabs. Do not deform the legs. See **Figure 11**.
  - 4.4. Carefully lift the heater can outward to clear the locking tabs and mounting tabs (screw mount holes).
5. Inspect the components as follows.
  - 5.1. The cell must be free of cracks that would cause leaks, resulting in incorrect oxygen readings.
  - 5.2. The cell mounting plate must be flat. The back of the mounting plate surface, especially where the Inconel metal O-ring makes contact, must be free of nicks and scratches that would prevent the O-ring from seating properly, resulting in leaks. See **Figure 12**.
  - 5.3. If the cell is full of fly ash, rinse it in distilled water until it is free of sediment.
  - 5.4. The insulation between the outside heater cylinder wall and the inside heater mandrel should be intact, not crumbling.

- 
- 5.5. The cell leads should be free of kinks or nicks that can damage the platinum wires. Do not touch the leads with copper or aluminum tools. Check resistance: it should be greater than one mega ohm between the leads with no shorts between the leads and the outside cylinder wall.
  - 5.6. Confirm that the RTD leads are in good condition as with cell leads in step 5.6 above. Check resistance: it should be 109 ohms at 80F (27C) ambient.
  6. To assemble the cell/heater/RTD, refer to **Figure 13** and 14 and proceed as follows.
    - 6.1. Install the heater onto the cell assembly. Gently grasp the cell mounting straps and exert pressure outward (see **Figure 11**) until the heater assembly is free to move onto the cell assembly. Be careful not to damage the cell leads.
    - 6.2. Align the heater leads and cell leads as shown in **Figure 13**. Push downward on the heater assembly to lock the tabs into the holes in the outside heater wall. There will be a gap between the cell and heater mandrel as shown in **Figure 13**.
    - 6.3. Install the RTD, referring to **Figure 13** for the proper location and position of the components and leads. Be careful not to damage the RTD leads. The RTD must make contact with both the heater mandrel and the cell.
    - 6.4. Holding the RTD in the position shown in **Figure 13**, pack it with loose insulation (Item 7). Make sure the insulation is clean and dry. Do not tamp it down: press just enough so that the packing is firm enough to support the RTD leads.
  7. To attach the sensor assembly to the lead bundle, refer to **Figures 2, 14** and **15**. Double-check the wiring of the cell, heater and RTD to the connector bundle, then proceed as follows.
    - 7.1. Slip a new metal Inconel O-ring over the cell mounting legs. Slide it up to the cell mounting plate: the O-ring will be seated into the groove later.
    - 7.2. Mount the sensor into the lead bundle as in **Figure 14**. Fan out the sensor leads so that they clear the ceramic terminal block. Using the new hardware provided in the kits, attach three sensor-mounting screws and special self-locking nuts. Do not use lock washers. Be sure that the reference gas tube-mounting tab is held by one of these screws.
    - 7.3. Torque the nuts to 25 in-lbs (2.8 Nm) or until they are snug against the ceramic terminal block.
  - 7.4. Check the terminal wiring numbers, referring to **Figure 7**. Check the key (connector guide pin hole: see **Figure 17** inset) on the plug-in connector end of the bundle (opposite end from the cell end). From the key hole, the terminals are one through six moving clockwise. Note that on the cell end, the terminals are one through six moving counter-clockwise.
  - 7.5. To attach lead wires, six 6-32 x 5/15 SS screws (provided in kit) are inserted through the ring terminals to the connector tabs. Refer to **Figure 15**. Lead wires around the ring terminals must be against the tabs (not under the screw heads).
  - 7.6. Tighten the terminal screws while holding the ring terminals with your fingers so that the lead wires are not twisted.
  8. To insert the connector bundle assembly, first check the position of the metal O-ring. It should be loose behind the cell mounting plate, from step 7.1 above.
    - 8.1. Align the connector bundle assembly, positioning it so that the calibration tube at the sensor end of the probe is lined up with terminal 6. This provides the proper orientation for the connector/conduit runs.
    - 8.2. To position the metal O-ring, check the O-ring groove in the flange weldment. It should be clean and free of nicks. Do not use O-ring lubricants. Push the O-ring into the groove with your fingers. Slide the assembled sensor/connector bundle into the probe body so that the back of the cell mounting plate contacts the O-ring. There should be even spacing all around between the cell mounting plate and the flange. The O-ring must stay seated to maintain a leak-tight seal.
  9. Install the sensor mounting-mating flange (Item 11) as shown in **Figure 2**.
    - 9.1 Approaching the probe welded flange straight on, mate the hole in the mating flange to the calibration tube. Do not hammer: use hands only. The connection will be tight.
  10. Check resistance at the connector bundle rods on the plug-in connector end of the probe. Resistance values should be as follows.
    - 10.1. Pins #1 and #2 are the cell leads. Resistance should be greater than 1 mega ohm at room (ambient) temperature of 80F (27C).
    - 10.2. Pins #3 and #4 are the heater leads. Resistance should be 18 to 20 ohms.
-

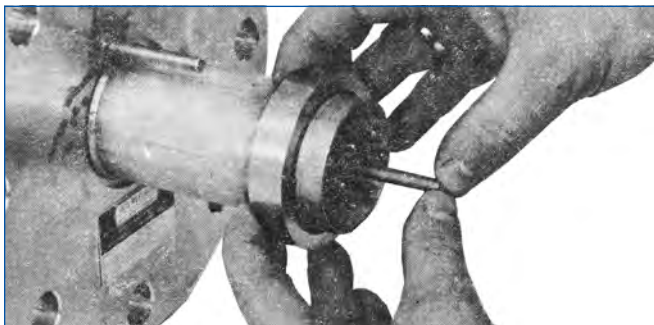
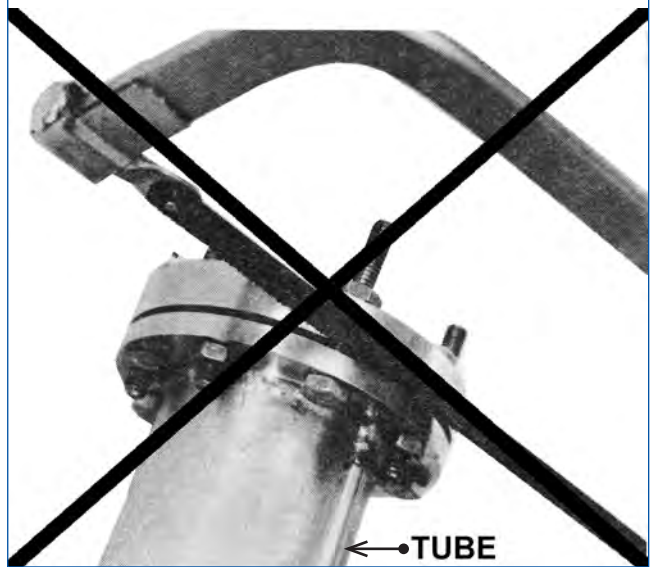
- 10.3. Pins #5 and #6 are the RTD leads. Resistance should be 108 to 110 ohms at 80F (27C).
- 10.4. Shorts and grounds. Resistance should be greater than one mega ohm between all other pin combinations and between any pin and the probe body.
11. For models without flame arrestor, insert and align the sensor flange bolts as follows. For models equipped with a flame arrestor, skip down to step 11.6.
- 11.1. Insert three ¼-20 x 1-3/4" bolts (Item 19) so that the threads extend outward toward the filter end of the probe. The bolts should be located so as to direct the "V" surface of the filter deflector into the direction of the flue gas flow. Insert five ¼-20 x 1- ½" bolts (Item 7) so that the threads also extend outward toward the filter end of the probe.
- 11.2. Apply anti-gall lubricant to the threads of the eight bolts just inserted. Use a heavy-duty hydrocarbon anti-seize such as Fel-Pro C-100TM (molybdenum disulphide paste).

- 11.3. Insert the filter gasket into the sensor-mounting mating flange.
- 11.4. Position the filter along with the filter deflector onto the three longer bolts. Seat it against the filter gasket.
- 11.5. Thread eight ¼-20 hex nuts onto the bolts. Finger-tighten only. Do not use lock washers.
- 11.6. For models equipped with flame arrestors, insert and align the sensor flange bolts as follows. Insert eight ¼-20 x 1-½" bolts (Item 7) so that the threads extend outward toward the filter end of the probe. Filter deflector vanes should be aligned as in step 11.1 above.
- 11.7. Apply anti-gall lubricant to the threads of the eight bolts just inserted. Use a heavy-duty hydrocarbon anti-seize such as Fel-Pro C-100TM (molybdenum disulphide paste).
- 11.8. Thread eight ¼-20 hex nuts onto the bolts. Finger-tighten only. Do not use lock washers.

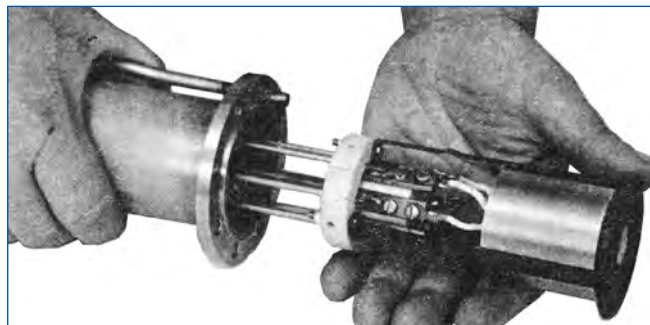
**Figure 3:** Proper way to saw galled (frozen) flange bolts.



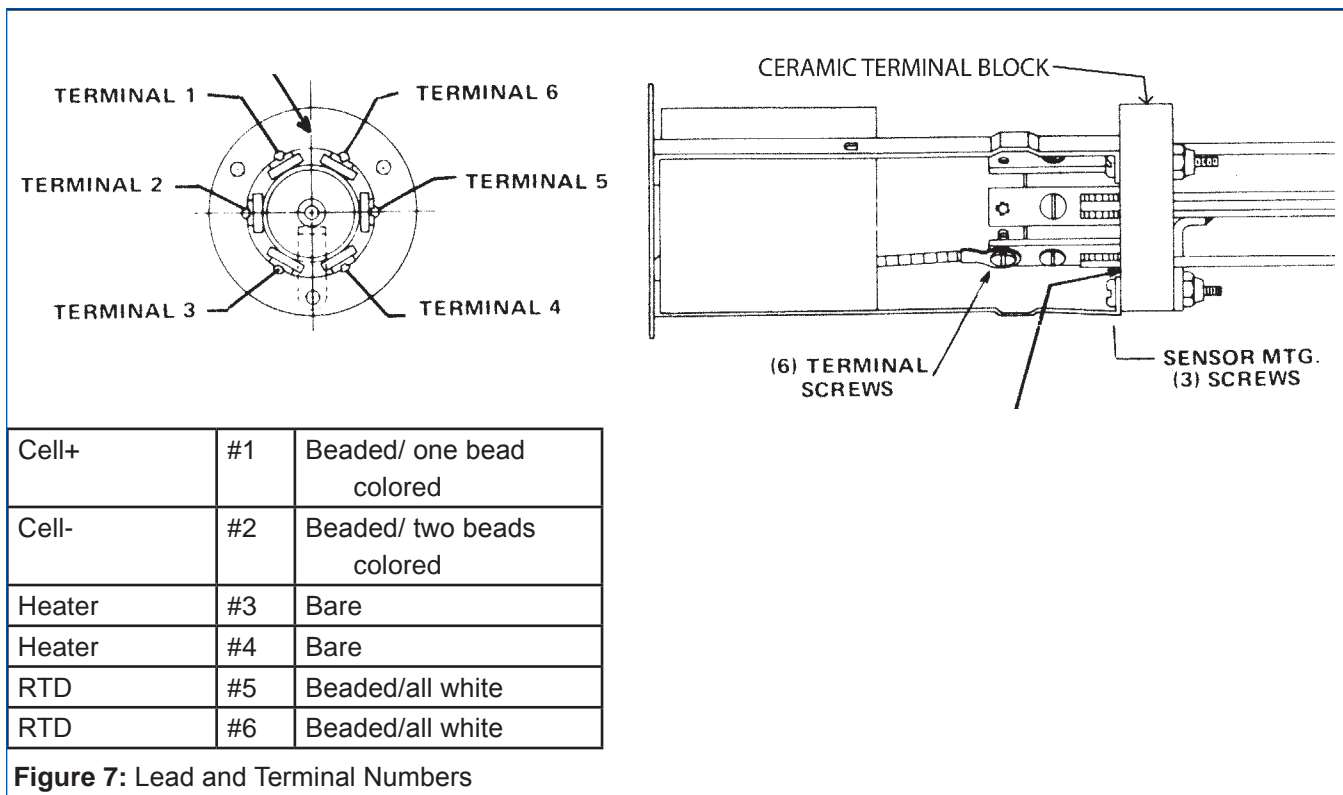
**Figure 4:** Do not saw galled (frozen) flange bolts this way: the tube will be cut.



**Figure 5:** Push on the reference tube to remove the cell/lead bundle assembly.



**Figure 6:** Carefully slide out lead bundle assembly and remove ceramic terminal block.



11.9. Tighten the sensor head flange. The gap between the sensor-mounting flange and the probe body flange should appear to be the same dimension all the way around, indicating proper O-ring seating. Inspect after each step. Finger-tighten the nuts to bring the flanges together squarely.

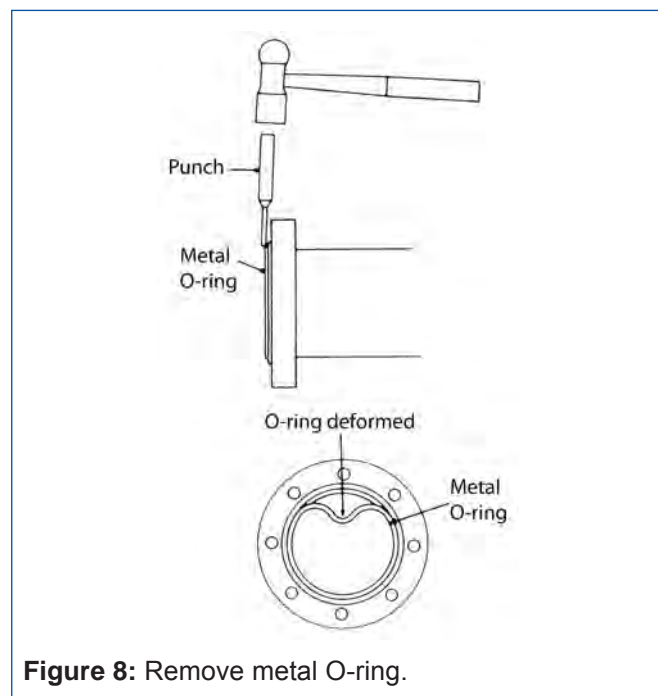
11.10. Using two 7/16" open-end wrenches, start tightening the eight bolts following the torquing sequence in **Figure 16**. Torque all eight nuts to 20 inch-pounds (2.3 Nm), then to 50 inch-pounds (5.6 Nm), and finally up to 85 inch-pounds (9.6 Nm). Important: refer to Fig. 16 for the torquing pattern: rotate around the flange tightening every third nut until all are at 20 inch-pounds. Then repeat for 50 and 85 inch-pounds. Damage to the filter casting can occur if bolts are tightened all the way at once.

12. Reinstall the oxygen analyzer probe, referring to **Figure 17**.

12.1. Determine the direction of the flue gas flow.

12.2. Use a 1/16"-thick ring gasket (P/N 1048-336A) between the probe mounting flange and the installation flange when remounting the oxygen analyzer probe.

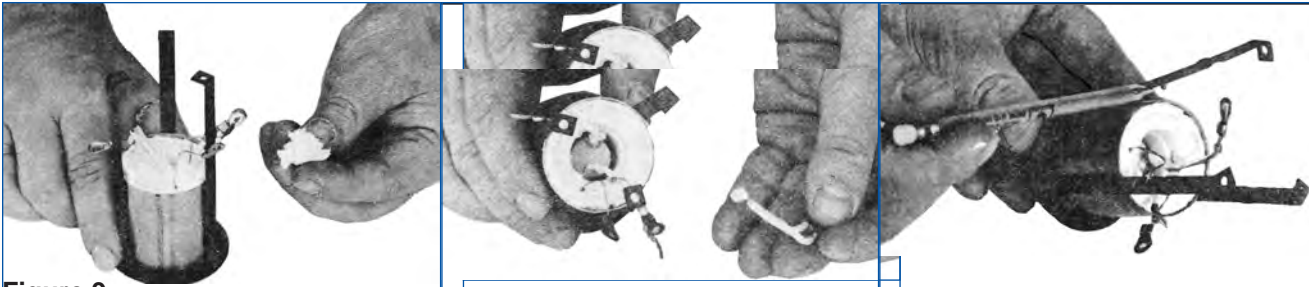
12.3. Install the probe so that the filter deflector vane is directed into the flue gas flow. Misalignment of the filter deflector vane and the flue can damage or plug the filter due to particulates in the flue gas.



12.4. Tighten all eight nuts and bolts on the mounting flange. See Fig. 16 for the correct torquing pattern. Reconnect the electrical connector assembly. Make sure the connector is free of dirt and dust.

12.5. Apply AC line power and allow thirty minutes for warm-up.

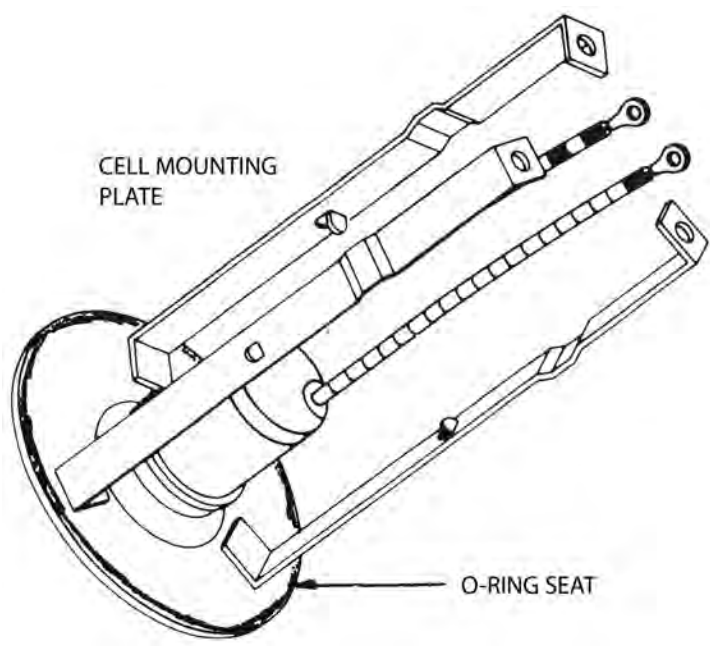
12.6. Calibrate according to instructions in the oxygen analyzer manual. Calibrate again after 48 hours to eliminate the minor drifting that can occur after cleaning or replacing components.



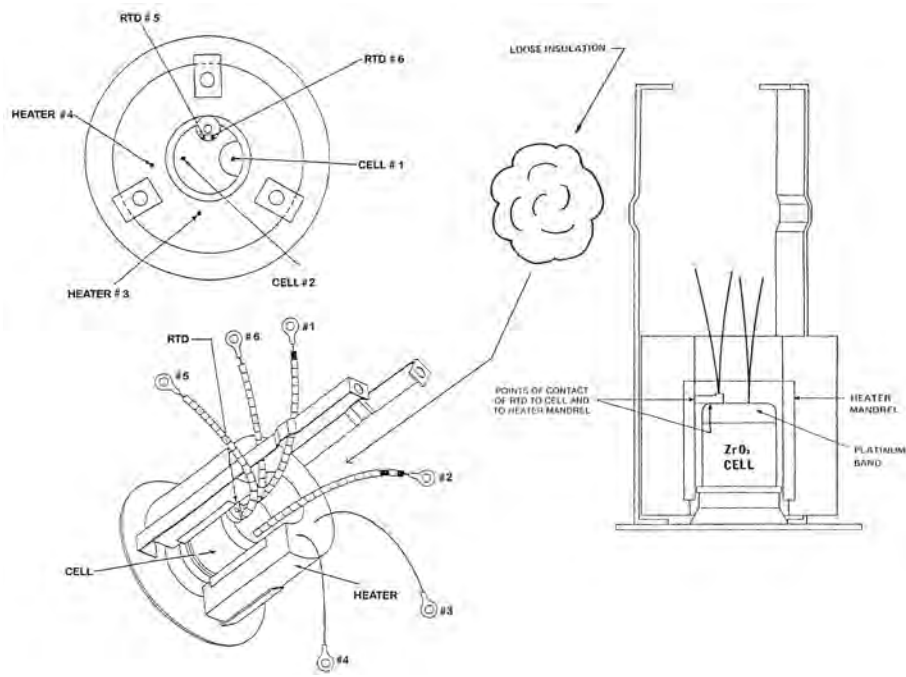
**Figure 9:**  
Remove cell insulation packing.

**Figure 10:** Remove the RTD.

**Figure 11:** Release the locking tabs.



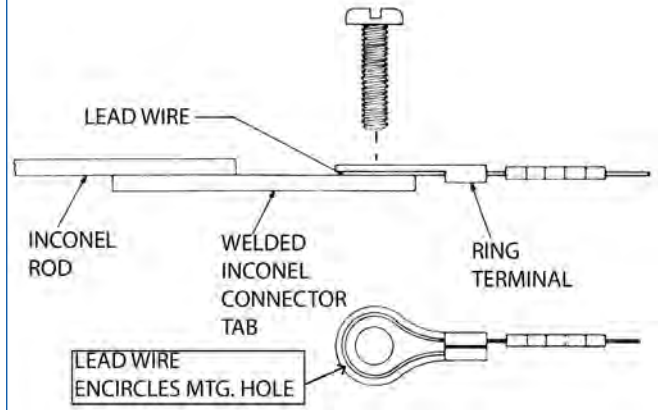
**Figure 12:** Avoid nicks and scratches to the area where the O-ring makes contact.



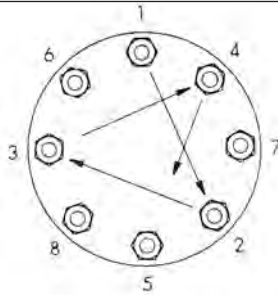
**Figure 13:** Components and Leads



**Figure 14:**  
Mount sensor assembly to connector bundle.

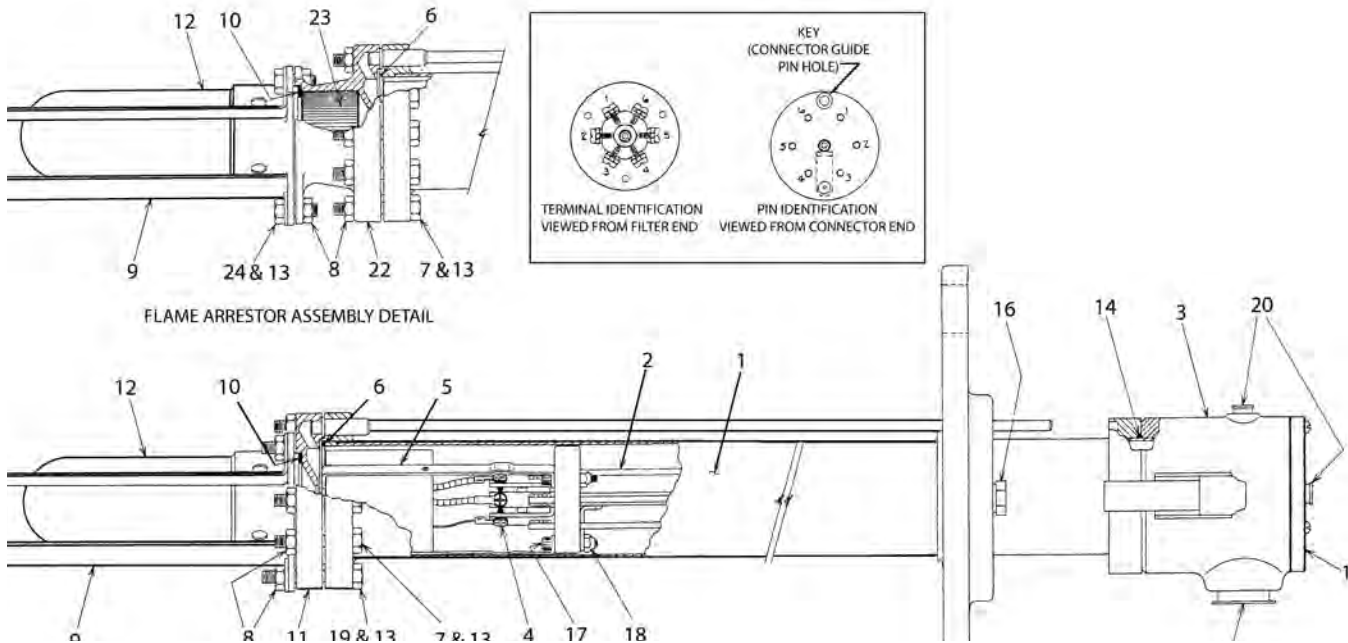


**Figure 15:** Lead wire attachment.



**Figure 16:** Torqueing Sequence for mounting flange bolts: tighten every third bolt until finished.

Figure 17:Parts



**Item Description of Parts Shown in Fig. 17**

- 1 Probe Flange Weldment Assembly
- 2 Connector Bundle Assembly
- 3 Connector Assembly
- 4 #6-32 x 5/16 LG PPHMS (SS)
- 5 Heater Cell Assembly
- 6 O-ring, Inconel
- 7 1/4-20 x 1-1/2 LG Hex HD Bolt (SS)
- 8 1/4-20 Hex Nut (SS)
- 9 Filter Support/Deflector Assy.
- 10 Gasket
- 11 Sensor Mtg. Mating Flange
- 12 Filter Assy
- 13 Hi-Temp Anti-Gall Lubricant
- 14 O-ring, Viton
- 15 Data Label
- 16 1/4 NPT Hex Hd Plug (SS)
- 17 #6-32 x 7/8 LG SHCS (SS)
- 18 #6-32 Self-Locking Nut
- 19 1/4-20 x 1-3/4 LG Hex HD Bolt (SS)
- 20 Cap Plug
- 21 Cap Plug
- 22 Flame Arrester Housing/Flange
- 23 Flame Arrester
- 24 1/4-20 x 5/8 LG Hex Hd Bolt (SS)

*H*ays  
*C*leveland  
Div. of UniControl Inc.



## **CUSTOMER SERVICE INFORMATION**

### **Contacts**

#### **Hays Cleveland Sales Office**

1903 South Congress Avenue  
Boynton Beach FL 33426  
Telephone: 561.734.9400  
Fax: 561.734.8060  
email: [salescombustion@unicontrolinc.com](mailto:salescombustion@unicontrolinc.com)

#### **Hays Cleveland Customer Service Department**

1111 Brookpark Road  
Cleveland OH 44109  
Telephone: 216.398.4414  
Fax: 216.398.8556  
email: [customerservice@unicontrolinc.com](mailto:customerservice@unicontrolinc.com)

### **Visit us on the WEB!**

<http://www.hayscleveland.com>

### **Repairs**

Damaged or defective units may be returned to the factory for repair. However, factory authorization must be obtained before shipping whether warranty or non-warranty service is required, and all units must be shipped prepaid.

A letter of transmittal that includes the following information should accompany the returned instrument:

1. Location, type of service, and length of time in service of the unit.
  2. Description of the faulty operation of the device and the circumstances of the failure.
-

3. Name and telephone number of the person to contact if there are questions about the unit.
4. Indicate whether warranty or non-warranty service is requested.
5. Attach Purchase Order for all out-of-warranty repairs.
6. Complete shipping instructions for the return of the repaired instrument.
7. Original purchase order number and date of purchase.
8. Return Goods Authorization number provided by the factory when you called.

Clearly label the shipping container:

### **RETURN FOR REPAIR**

**Model** \_\_\_\_\_

**RG #** \_\_\_\_\_

Ship prepaid to:

**HAYS CLEVELAND**  
**1111 Brookpark Road**  
**Cleveland OH 44109-5869**  
**216-398-4414**



Please follow this procedure. It expedites handling of the returned item, and avoids unnecessary additional charges for inspection and testing to determine the problem before repairing it.

### **Service**

A **Maintenance and Service Contract** can ensure trouble-free, economical operation of **Hays Cleveland** equipment for many years. One-time on-site service by a factory-trained service engineer can also be provided as needed. Contact Hays Cleveland for information on these service options.

---

## Standard Terms and Conditions of Sale

**TERMS OF SALE:** 1% discount if paid in ten (10) days, net amount due and payable in thirty (30) days.

**AGREEMENT OF SALE:** Acceptance by Seller of any order placed for goods whether submitted on Buyer's purchase order form or on seller's Sales Order Acknowledgment form, shall be subject to Seller's Standard Terms and Conditions of Sale and is conditioned upon the Buyer's acceptance of these Standard Terms and Conditions.

**TERMS OF CONTRACT:** Any terms or conditions of the buyer's order which are inconsistent with these terms and conditions shall not be binding on the Seller and shall not be considered applicable to the sale or shipment of goods or materials. Unless buyer shall notify Seller in writing to the contrary within ten (10) days after the mailing of the Sales Contract by Seller, acceptance of the terms and conditions hereof by Buyer shall be indicated and, in the absence of such notification, the sale and shipment by Seller of the goods and materials covered hereby shall be conclusively deemed to be subject to the terms and conditions hereof.

**PRICES:** All prices and specifications and applicable discounts are subject to change without notice. Sales contracts which call for delivery in the future will be billed at prices in effect at the time of shipment. Shipping weights shown are approximate and subject to change without notice.

**SHIPMENT AND PAYMENTS:** All prices contained on the Sales Contract are F.O.B. factory in Cleveland, Ohio. No freight is allowed on any shipments. Shipments and deliveries shall at all times be subject to the approval of Seller's Credit Department, and at any time seller may require payment in advance or satisfactory security or guarantee that invoices will be promptly paid when due. If buyer fails to comply with any terms of payment, seller, in addition to its other rights and remedies, but not in limitation thereof, reserves the right to withhold further deliveries or terminate the Agreement, and any unpaid amount thereon shall become due immediately. Terms of payment shall be as set forth on the Sales Contract.

**DELAYS AND DEFAULTS:** Delays or defaults in delivery by Seller of the goods and materials covered by the Sales Contract shall be excused so far as the same is caused by fire, strikes, accident, governmental regulation, or any delays unavoidable or beyond reasonable control of Seller. In no event shall Seller be liable for any consequential, special, or contingent damages on account of any default or delay in delivery.

**NONCANCELLATION:** Orders are not subject to suspension, reduction, or cancellation, except on terms that will indemnify Seller against loss.

**SPECIFICATIONS:** Seller relies on specifications and other data furnished by the Buyer, an architect, contractor, or consulting engineer in all phases of the work covered by the Sales Contract. Seller shall be responsible to check quantities only. Alterations to or changes in specifications, approval of samples, changes in delivery instructions and all other instructions must be submitted in writing to Seller.

In the event Seller performs design or engineering work at the request of Buyer, an architect, contractor, consulting engineer, or representative in any phase of the work covered by the Sales Contract, Seller shall not be responsible for any damages claimed by Buyer as a result of alleged errors or defects in such design or engineering work.

**WARRANTY AND LIMITATION OF LIABILITY:** Seller warrants that the goods supplied by it have been manufactured in accordance with its standard manufacturing practices and conform to the contract or catalog description set forth in the order. Seller further warrants that the goods supplied by it are fit for the ordinary purpose or purposes specified in its catalog for which such goods are used when installed in accordance with Seller's recommended installation procedures. Except as stated herein, Seller makes no express warranty with respect to goods supplied by it and Seller makes no warranty that the goods are fit for any particular purpose.

---

When the use of materials not manufactured by Seller is suggested by Seller's recommended installation procedures or otherwise, Seller makes no express warranty with respect to such materials nor that such materials are merchantable or fit for any particular purpose.

Seller will, at its sole option, credit, repair or replace, any goods supplied by it which its examination shall disclose to its satisfaction are defective in workmanship or material and are returned to it within one year from the date of shipment and any claim not made within this period shall conclusively be deemed waived by Buyer. Credit, repair or replacement will be preconditioned upon examination of the goods by Seller, and, if requested by Seller, return of the goods to Seller at its direction and expense. No goods are to be returned to Seller without its written consent. Seller shall not be liable for any expense incurred by Buyer in order to remedy any defect in its goods. Seller shall not be liable for any consequential, special, or contingent damage or expense, arising directly or indirectly from any defect in its goods or from the use of any defective goods. The remedies set forth herein shall constitute the exclusive remedies available to Buyer and are in lieu of all other remedies.

**CLAIMS:** Claims for shortage of goods or for mistakes or errors in billing must be presented within forty-five (45) days from the date of shipment of goods and must state the packing slip number and container number applicable to the claim. Any claim not so presented will be conclusively deemed waived.

**TAXES:** Any federal taxes or other government charges on the sale, shipment, or installation of the goods or equipment covered by the Sales Contract shall be added to the price and paid by Buyer, or, in lieu thereof, the Buyer shall furnish the Seller with tax-exemption certificates acceptable to the taxing authority. The procedure also applies to duty and other similar charges on export sales. Seller is not responsible for sales and/or use tax in any state other than Ohio. The purchase made under this Sales Contract must be exempt or paid directly by Buyer. If Seller is required to pay any such tax, there shall be added to the prices quoted herein all such state and local taxes. Buyer agrees to reimburse and save Seller harmless from all such state and local taxes, including interest and penalties thereon, which may at any time be payable to any state or local government unit with respect to the sale of any goods or materials covered by the Sales Contract.

**CORRECTIONS:** Typographical or clerical errors contained in the Sales Contract, including prices, are subject to correction by the Seller.

**FAIR LABOR STANDARDS:** All goods covered by the Sales Contract have been produced in conformity with all applicable provisions of the Fair Labor Standards Act of 1938 as amended.

**RENEGOTIATION:** Unless advised by Buyer in writing, Seller assumes that Buyer's order and the Sales Contract are not renegotiable under the Renegotiation Act of 1951.

**APPLICABLE LAW:** All questions arising out of the Sales Contract, which shall be deemed an Ohio contract, shall be governed by the laws of the state of Ohio.

**EXCLUSIVE TERMS:** The Sales Contract shall constitute the complete contract between the parties, and no one has authority to depart from the terms and conditions set forth therein, nor to make any representations or arrangements other than those printed thereon whether in the execution or in the performance of the Sales Contract, unless the same are written on the face of the Sales Contract or are given in writing with it or in pursuance of it, and are fully approved in writing by an officer or authorized employee of the Seller.

**LIMITATION FOR SUITS:** Any controversy or claim arising out of or relating to this Sales Contract or the breach thereof, must be commenced within one (1) year after the cause of action accrued.



---

*H*ays  
*C*leveland  
Div. of UniControl Inc.