



**Controller
Indicator
Transmitter
1/32 DIN - 48 x 24**

Customer Service
1111 Brookpark Rd.
Cleveland OH 44109
Tel: 216.398.4444
Fax: 216.398.8558

Sales Office
1903 S. Congress Avenue
Boynton Beach FL 33426
Tel: 561.734.9400
Fax: 561.734.8060



**Series C1
Instruction Manual C1.01**



**Controller
Indicator
Transmitter
1/32 DIN - 48 x 24**

Customer Service
1111 Brookpark Rd.
Cleveland OH 44109
Tel: 216.398.4444
Fax: 216.398.8558

Sales Office
1903 S. Congress Avenue
Boynton Beach FL 33426
Tel: 561.734.9400
Fax: 561.734.8060



**Series C1
Instruction Manual C1.01**

Controller
Indicator
Transmitter

$\frac{1}{32}$ DIN - 48 x 24

C1 line **CE**

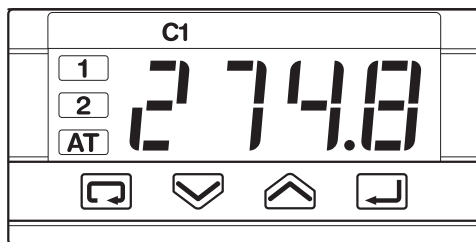

Controller
Indicator
Transmitter

$\frac{1}{32}$ DIN - 48 x 24

C1 line **CE**

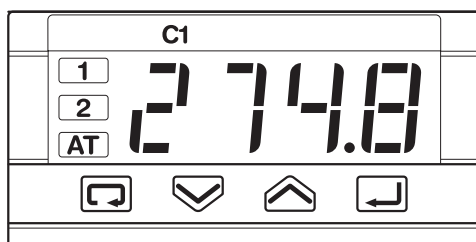



NOTES

ON ELECTRIC SAFETY AND ELECTROMAGNETIC COMPATIBILITY.

Please, read these instructions carefully before proceeding with the installation of the controller. Class II instrument.

This controller has been designed in compliance with: Regulations on electrical apparatus (appliance, systems and installations) according to the European Community directive 73/23 CEE amended by the European Community directive 93/68 CEE and the Regulations on the essential protection requirements in electrical apparatus EN 61010-1 (IEC 1010 - 1) : 90 +A1:92 + A2:95.

Regulations on Electromagnetic Compatibility according to the European Community directive n089/336/CEE, amended by the European Community directive n° 92/31/CEE and the following regulations: Regulations on RF emissions EN50081 - 1 residential environments EN50081 - 2 for industrial environments Regulation on RF immunity EN500082-2 for industrial equipment and system

It is the responsibility of the installer to ensure compliance with all local regulations and safety requirements.

This control has no user serviceable parts.

Should repair be necessary, contact the Hays Cleveland sales office from which the unit was purchased for instructions on returning it to the factory. Or call Hays Cleveland Customer Service at 216.398.4414,

All the information and warnings about safety and electromagnetic compatibility are marked with the CE sign, at the side of the note.



NOTES

ON ELECTRIC SAFETY AND ELECTROMAGNETIC COMPATIBILITY.

Please, read these instructions carefully before proceeding with the installation of the controller. Class II instrument.

This controller has been designed in compliance with: Regulations on electrical apparatus (appliance, systems and installations) according to the European Community directive 73/23 CEE amended by the European Community directive 93/68 CEE and the Regulations on the essential protection requirements in electrical apparatus EN 61010-1 (IEC 1010 - 1) : 90 +A1:92 + A2:95.

Regulations on Electromagnetic Compatibility according to the European Community directive n089/336/CEE, amended by the European Community directive n° 92/31/CEE and the following regulations: Regulations on RF emissions EN50081 - 1 residential environments EN50081 - 2 for industrial environments Regulation on RF immunity EN500082-2 for industrial equipment and system

It is the responsibility of the installer to ensure compliance with all local regulations and safety requirements.

This control has no user serviceable parts.

Should repair be necessary, contact the Hays Cleveland sales office from which the unit was purchased for instructions on returning it to the factory. Or call Hays Cleveland Customer Service at 216.398.4414,

All the information and warnings about safety and electromagnetic compatibility are marked with the CE sign, at the side of the note.

TABLE OF CONTENTS

1	Installation	Page 4
2	Electical Connections	Page 8
3	Product Codes (Nomenclature)	Page 14
4	Operation	Page 18
5	Automatic Tuning	Page 28
6	TECHNICAL SPECIFICATIONS	Page 29

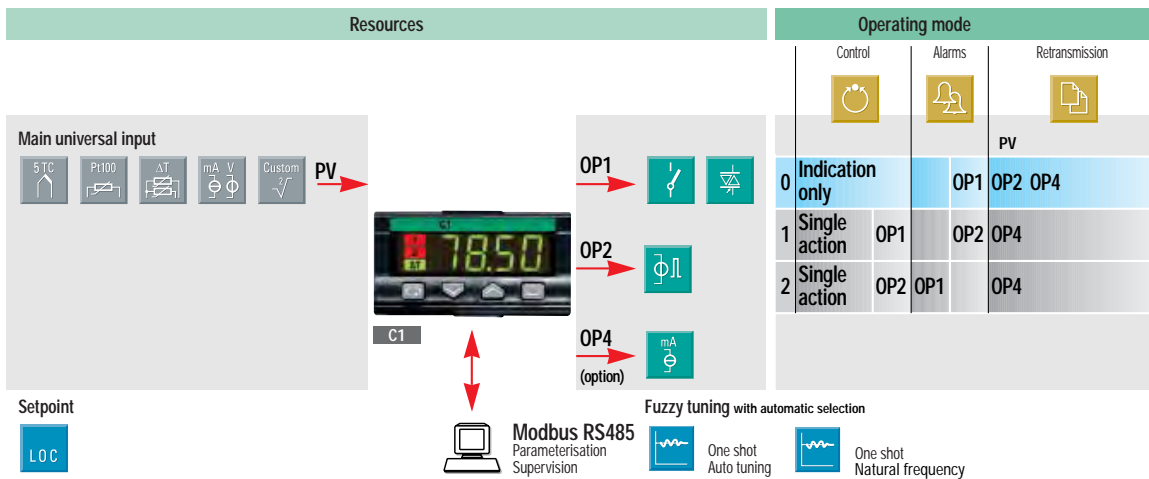
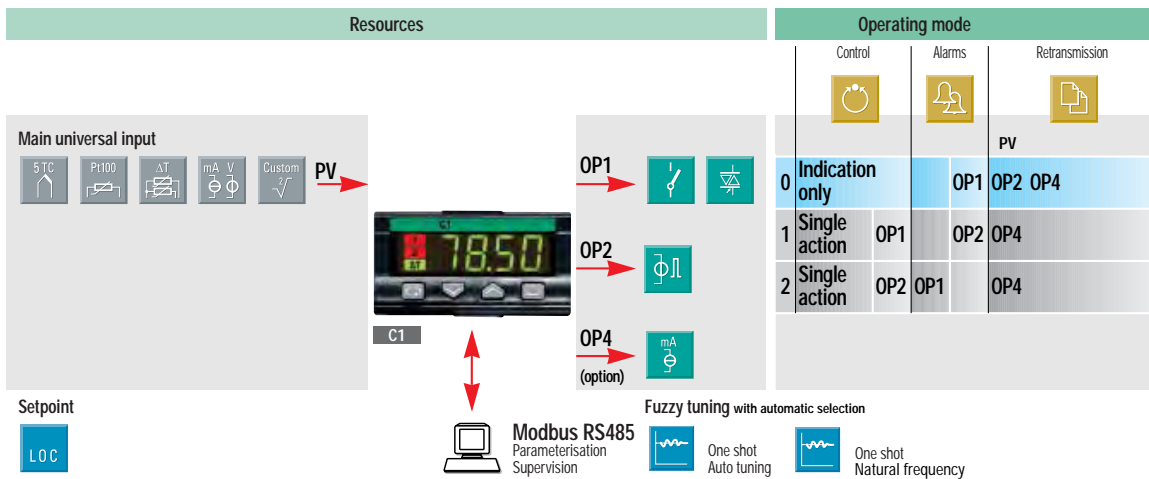



TABLE OF CONTENTS

1	Installation	Page 4
2	Electical Connections	Page 8
3	Product Codes (Nomenclature)	Page 14
4	Operation	Page 18
5	Automatic Tuning	Page 28
6	TECHNICAL SPECIFICATIONS	Page 29



INSTALLATION

Installation must only be carried out by qualified personnel.

Before proceeding with the installation of this controller, follow the instructions illustrated in this manual, particularly the installation precautions marked with the  symbol, related to the European Community directive on electrical protection and electromagnetic compatibility.



To prevent hands or metal touching parts that may be electrically live, this control must be installed in an enclosure and/or in a cubicle.

1.1 GENERAL DESCRIPTION

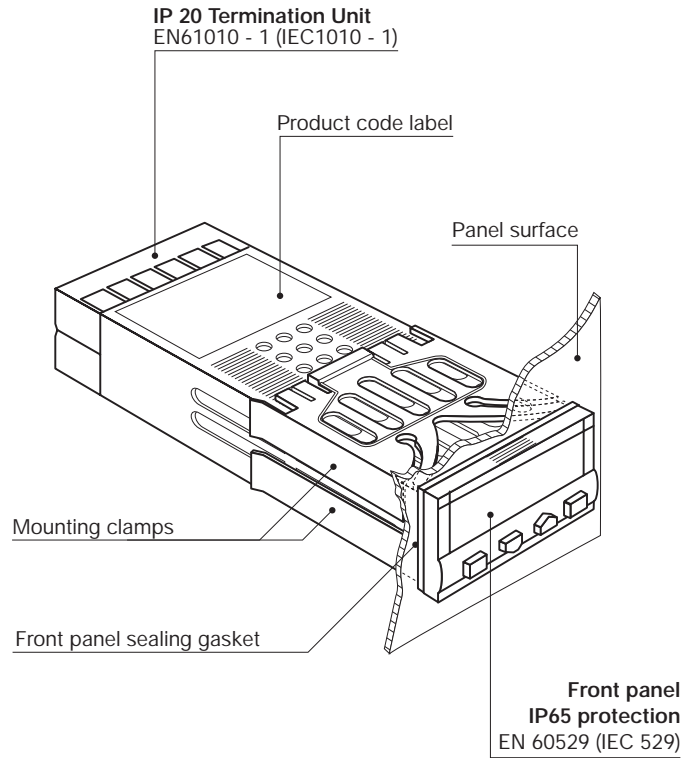

INSTALLATION

Installation must only be carried out by qualified personnel.

Before proceeding with the installation of this controller, follow the instructions illustrated in this manual, particularly the installation precautions marked with the  symbol, related to the European Community directive on electrical protection and electromagnetic compatibility.



To prevent hands or metal touching parts that may be electrically live, this control must be installed in an enclosure and/or in a cubicle.

1.1 GENERAL DESCRIPTION

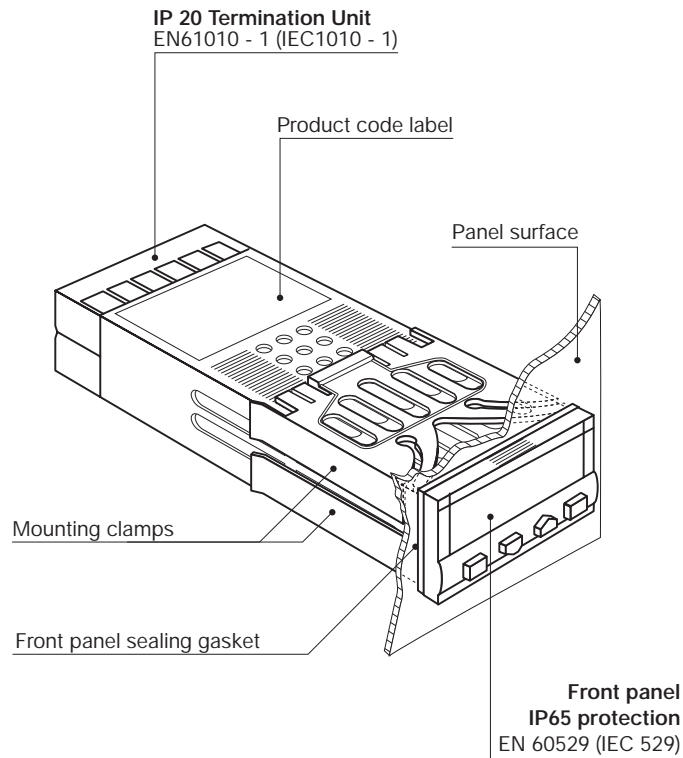

1 - Installation

1.2 C1 DIMENSIONS

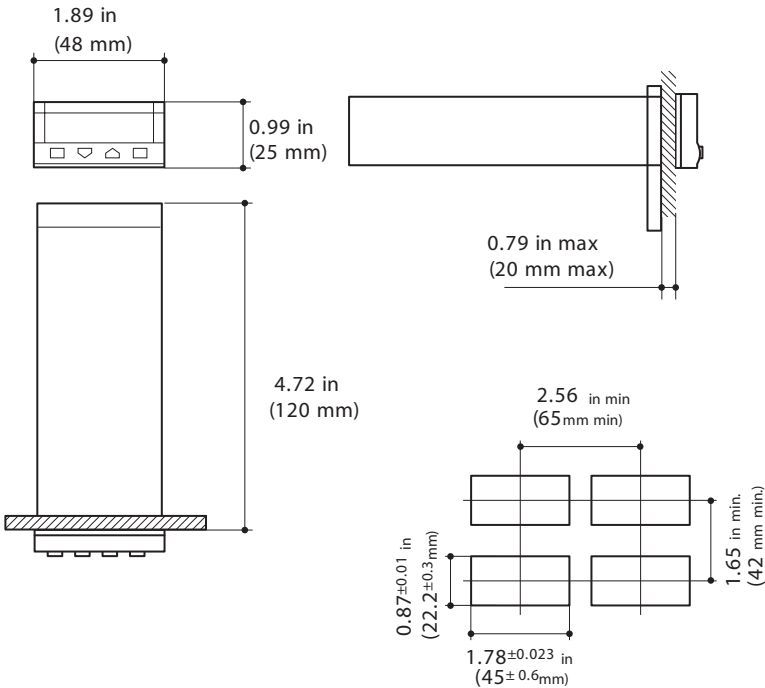

1 - Installation

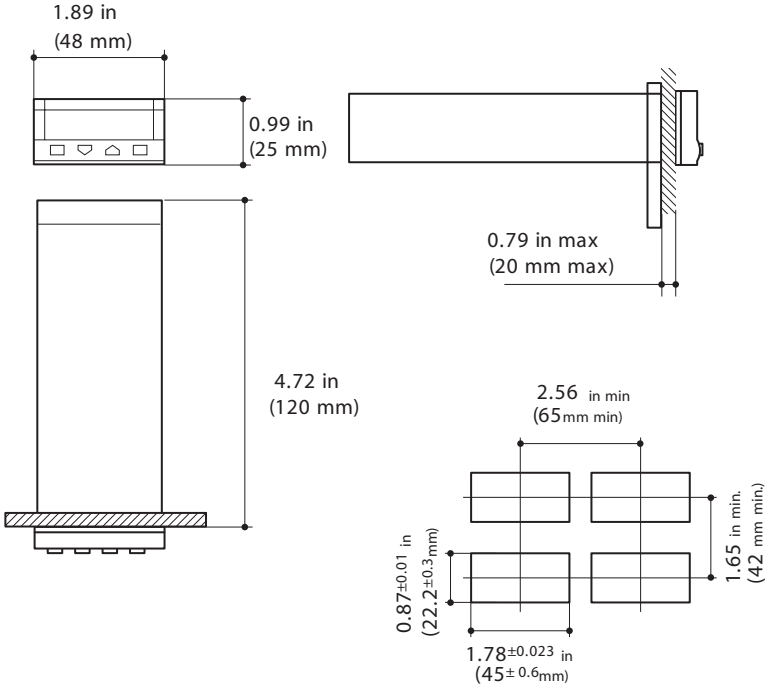

1.2 C1 DIMENSIONS





1.4 ENVIRONMENTAL RATINGS





Operating conditions

 2000	Altitude up to 6500 ft. (2000 m)
	Temperature 32-106 F (0-50 C)
%Rh	Relative humidity 5-95 %, non-condensing

Special conditions	Suggestions
 2000	Altitude > 6500 ft. (2000 m) Use 24VAC supply version
	Temperature >106F (50C) Use forced air ventilation
%Rh	Humidity > 95% Warm up
	Conducting atmosphere Use filter



Forbidden Conditions 



	Corrosive atmosphere
	Explosive atmosphere

1.4 ENVIRONMENTAL RATINGS





Operating conditions

 2000	Altitude up to 6500 ft. (2000 m)
	Temperature 32-106 F (0-50 C)
%Rh	Relative humidity 5-95 %, non-condensing

Special conditions	Suggestions
 2000	Altitude > 6500 ft. (2000 m) Use 24VAC supply version
	Temperature >106F (50C) Use forced air ventilation
%Rh	Humidity > 95% Warm up
	Conducting atmosphere Use filter

Forbidden Conditions 

	Corrosive atmosphere
	Explosive atmosphere

1.5 PANEL MOUNTING**1.5.1 INSERT THE INSTRUMENT**

- 1 Prepare panel cut-out.
- 2 Check front panel gasket position.
- 3 Insert the instrument through the cut-out.

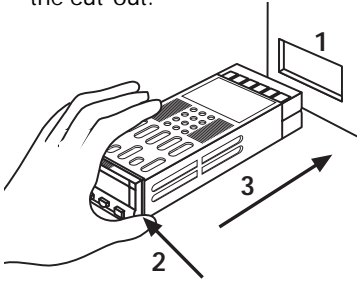
**1.5.2 SECURING CLAMPS**

- 1 Position the mounting clamps.
- 2 Push the mounting clamps toward the panel surface to secure the instrument.

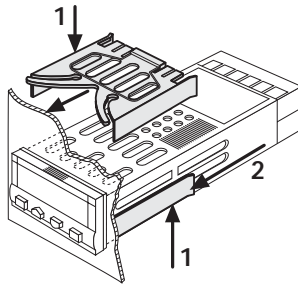
**1.5.3 REMOVING CLAMPS**

- 1 Insert a screwdriver into the clips of the clamps.
- 2 Rotate the screwdriver.

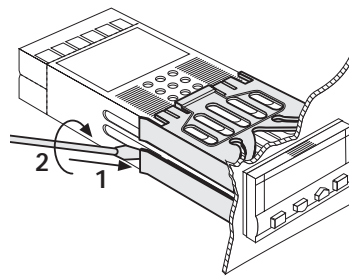
**1.5.4 UNPLUGGING INSTRUMENT**

- 1 Push and then
- 2 pull to remove the instrument.

Electrostatic discharges can damage the instrument. Before removing the instrument the operator must discharge himself to ground.

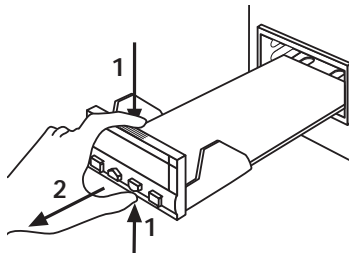

I

1.5 PANEL MOUNTING**1.5.1 INSERT THE INSTRUMENT**

- 1 Prepare panel cut-out.
- 2 Check front panel gasket position.
- 3 Insert the instrument through the cut-out.

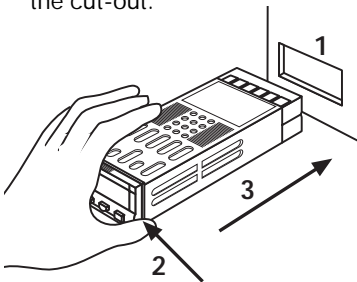
**1.5.2 SECURING CLAMPS**

- 1 Position the mounting clamps.
- 2 Push the mounting clamps toward the panel surface to secure the instrument.

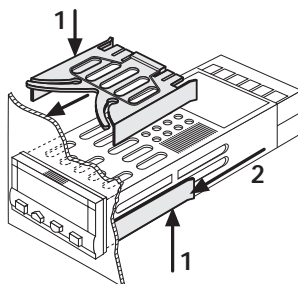
**1.5.3 REMOVING CLAMPS**

- 1 Insert a screwdriver into the clips of the clamps.
- 2 Rotate the screwdriver.

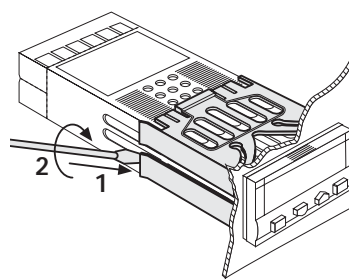
**1.5.4 UNPLUGGING INSTRUMENT**

- 1 Push and then
- 2 pull to remove the instrument.

Electrostatic discharges can damage the instrument. Before removing the instrument the operator must discharge himself to ground.

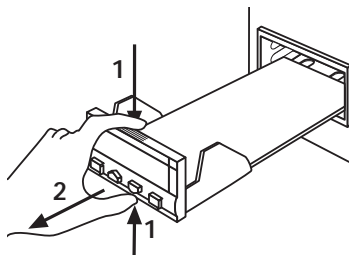

I

ELECTRICAL CONNECTIONS

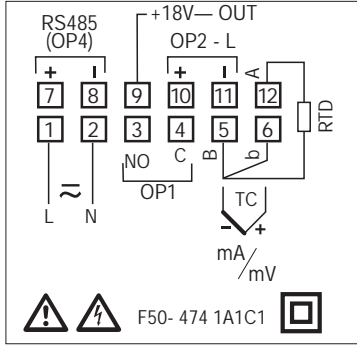

2.1 TERMINATION UNIT

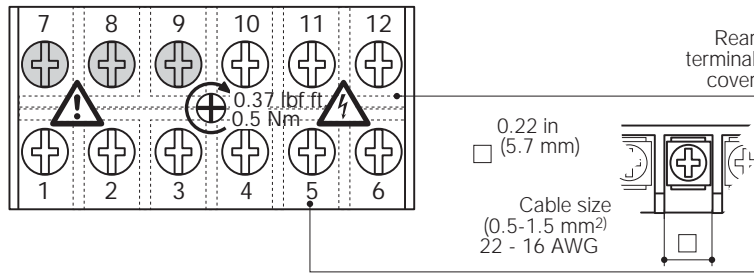

12 screw terminals



Option terminals



Holding screw 0.5 Nm



Positive screw driver PH1



Negative screw driver 0.8 x 4 mm

Recommended wire terminal leads

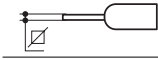

Pin connector \varnothing = 0.055 in (1.4 mm) max



Fork-shape AMP 165004 \varnothing = 0.21 in (5.5 mm)

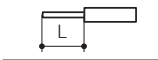

Stripped wire L = 0.21 in (5.5 mm)

ELECTRICAL CONNECTIONS

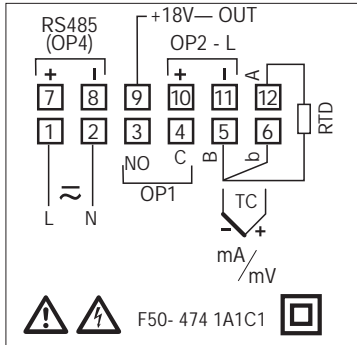

2.1 TERMINATION UNIT

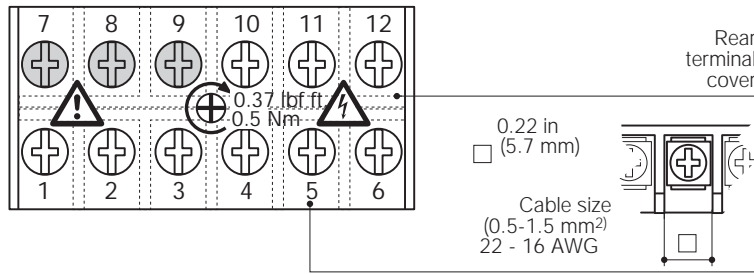

12 screw terminals



Option terminals



Holding screw 0.5 Nm



Positive screw driver PH1



Negative screw driver 0.8 x 4 mm

Recommended wire terminal leads

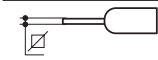

Pin connector \varnothing = 0.055 in (1.4 mm) max



Fork-shape AMP 165004 \varnothing = 0.21 in (5.5 mm)

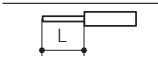

Stripped wire L = 0.21 in (5.5 mm)

PRECAUTIONS



Although this instrument has been designed to work in a harsh, noisy industrial environment, (level IV of the industrial standard IEC 801-4), the following suggestions are strongly recommended.



All wiring must comply with local regulations!

The supply wiring should be routed away from the power cables. Avoid using electromagnetic contactors, power relays and high power motors nearby. Avoid power units nearby, especially if controlled in phase angle.

Keep the low level sensor input wires away from the power lines and the output cables. If this is not possible, use shielded cables on the sensor input, with the shield connected to earth.

2.2 RECOMMENDED ROUTING OF WIRES

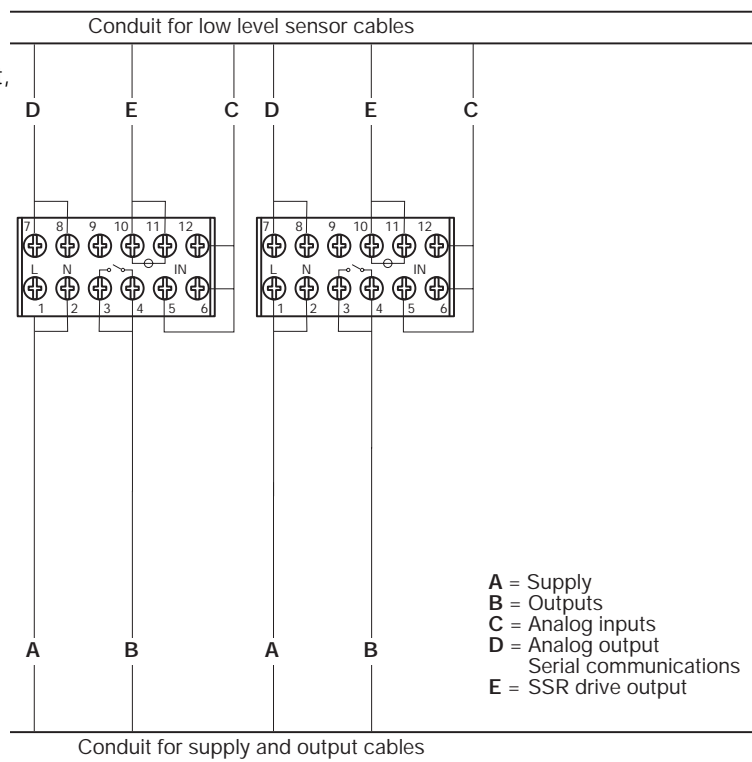

PRECAUTIONS



Although this instrument has been designed to work in a harsh, noisy industrial environment, (level IV of the industrial standard IEC 801-4), the following suggestions are strongly recommended.



All wiring must comply with local regulations!

The supply wiring should be routed away from the power cables. Avoid using electromagnetic contactors, power relays and high power motors nearby. Avoid power units nearby, especially if controlled in phase angle.

Keep the low level sensor input wires away from the power lines and the output cables. If this is not possible, use shielded cables on the sensor input, with the shield connected to earth.

2.2 RECOMMENDED ROUTING OF WIRES

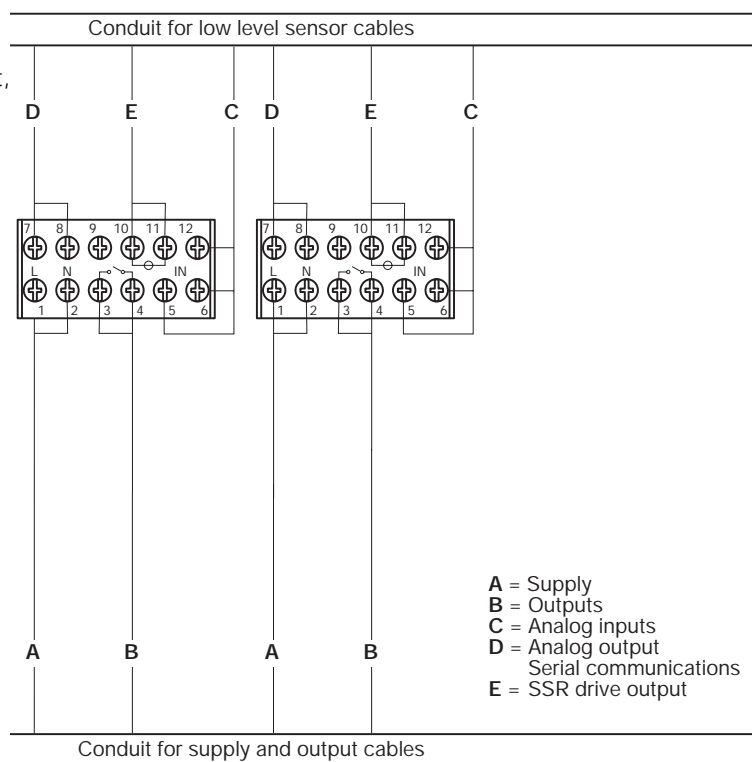

2.3 TYPICAL INSTRUMENT WIRING

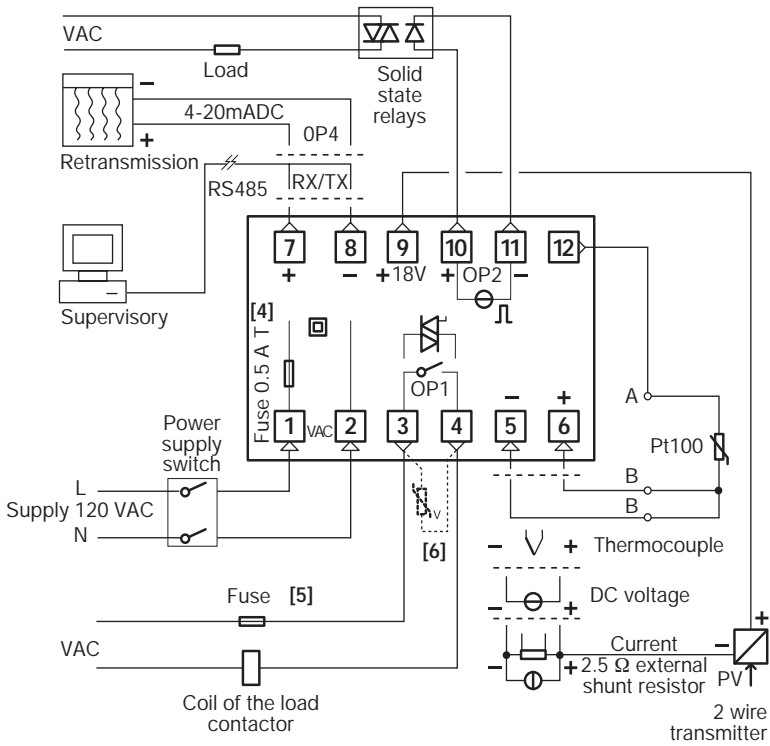

Notes:

- 1) Make sure the power supply voltage is the same as indicated on the instrument.
- 2) Switch on the power supply only after that all the electrical connections have been completed.
- 3) In accordance with safety regulations, the power supply switch carries the identification of the relevant instrument. The power supply switch is easily accessible from the operator.
- 4) The instrument is protected with a 0.5 AC time lag fuse. In case of failure, return the unit to the Hays Cleveland Customer Service office for repair.
- 5) To protect the instrument internal circuits use:
 - 2 A AC time lag fuses for Relay outputs
 - 1 A AC time lag fuses for Triac outputs
- 6) Relay contacts are already protected with varistors.

Only in case of 24 V AC inductive loads, use model A51-065-30D7 varistors (on request).

2.3 TYPICAL INSTRUMENT WIRING

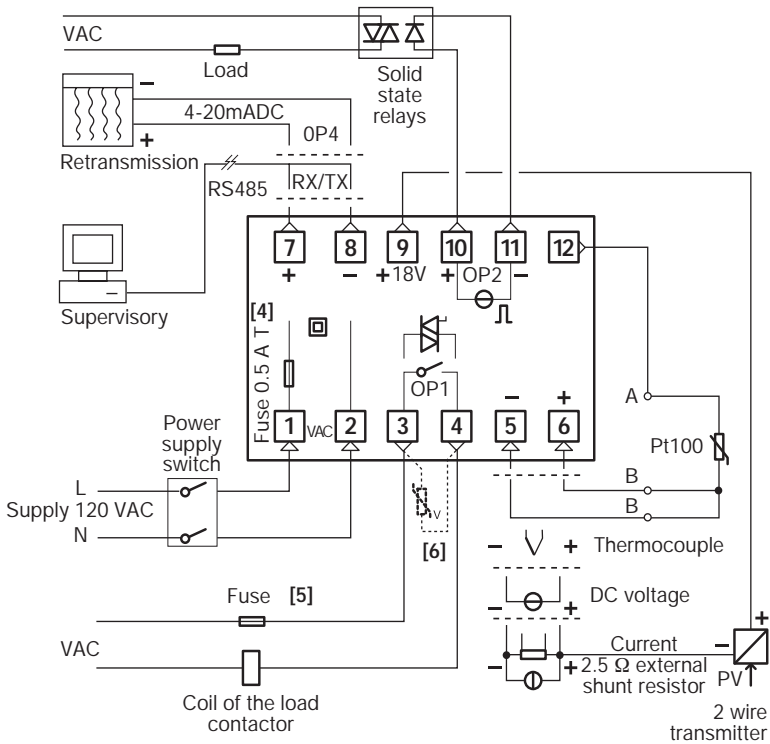

Notes:

- 1) Make sure the power supply voltage is the same as indicated on the instrument.
- 2) Switch on the power supply only after that all the electrical connections have been completed.
- 3) In accordance with safety regulations, the power supply switch carries the identification of the relevant instrument. The power supply switch is easily accessible from the operator.
- 4) The instrument is protected with a 0.5 AC time lag fuse. In case of failure, return the unit to the Hays Cleveland Customer Service office for repair.
- 5) To protect the instrument internal circuits use:
 - 2 A AC time lag fuses for Relay outputs
 - 1 A AC time lag fuses for Triac outputs
- 6) Relay contacts are already protected with varistors.

Only in case of 24 V AC inductive loads, use model A51-065-30D7 varistors (on request).

2.3.1 POWER SUPPLY

Switching power supply with multiple isolation and internal fuse:

- Standard version:
nominal voltage:
100 - 240VAC (- 15% + 10%)
Frequency 50/60Hz.
- Low Voltage version:
Nominal voltage:
24VAC (- 25% + 12%)
Frequency 50/60Hz.
or 24V. (- 15% + 25%)
- Power consumption 1.6W max.

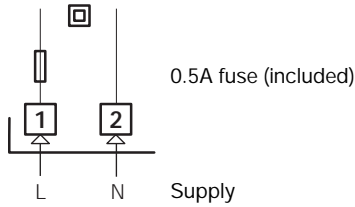

2.3.2 OP1 OUTPUT

A) Single relay output

- NO contact for resistive load of up to 2A / 250 VAC max.
- 2A. AC Time lag Fuse (IEC 127)

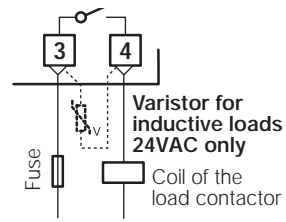

B) Triac Output

- NO contact for resistive load of up to 1A / 250 VAC max.
- 1A. AC Time lag Fuse (IEC 127)

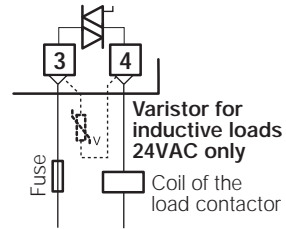

2.3.3 OP2 OUTPUT

SSR (solid state relay) drive output, not isolated
0-5V., ±20%, 30mA, max.

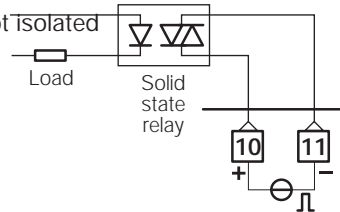

2.3.1 POWER SUPPLY

Switching power supply with multiple isolation and internal fuse:

- Standard version:
nominal voltage:
100 - 240VAC (- 15% + 10%)
Frequency 50/60Hz.
- Low Voltage version:
Nominal voltage:
24VAC (- 25% + 12%)
Frequency 50/60Hz.
or 24V. (- 15% + 25%)
- Power consumption 1.6W max.

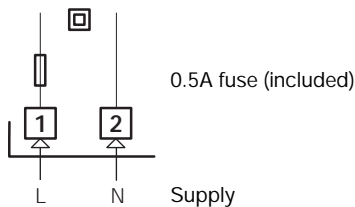

2.3.2 OP1 OUTPUT

A) Single relay output

- NO contact for resistive load of up to 2A / 250 VAC max.
- 2A. AC Time lag Fuse (IEC 127)



B) Triac Output

- NO contact for resistive load of up to 1A / 250 VAC max.
- 1A. AC Time lag Fuse (IEC 127)

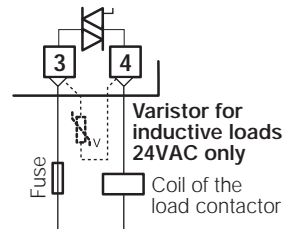

2.3.3 OP2 OUTPUT

SSR (solid state relay) drive output, not isolated
0-5V., ±20%, 30mA, max.

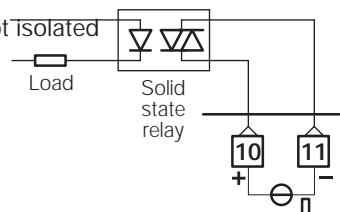

2.3.4 PV CONTROL INPUT

B

- Connect the wires with the polarity as shown. Use always compensation cable of the correct type for the thermocouple used. The shield, if present, must be connected to a proper ground.

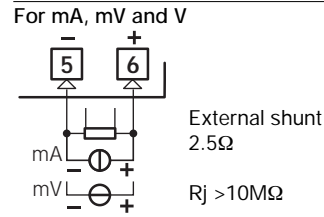
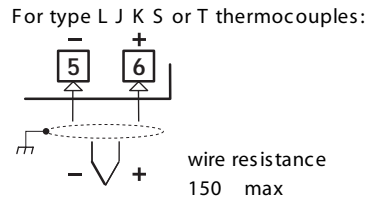

- For a 3-wire system, always use cables of the same diameter (1 mm² minimum.) (line 20 Ω/lead maximum resistance)
- For a 2-wire system, always use cables of the same diameter (1.5mm² min.) and put a jumper between terminals 5 and 6.

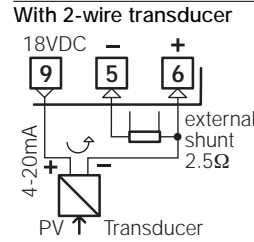
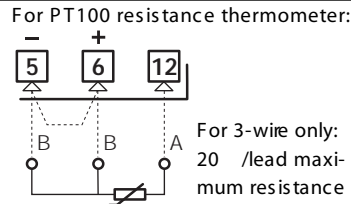

- When the distance between the controller and the sensor is 50 ft. (15 mt.), using cable of 1.5 mm² diameter, an error of approx. 2° F (1° C) is produced.

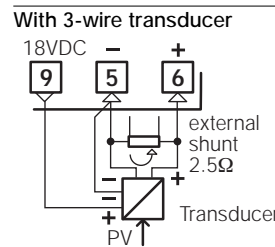
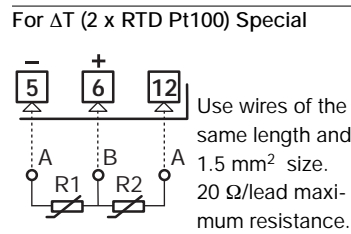

R1 + R2 must be < 320Ω

2.3.4 PV CONTROL INPUT

B

- Connect the wires with the polarity as shown. Use always compensation cable of the correct type for the thermocouple used. The shield, if present, must be connected to a proper ground.

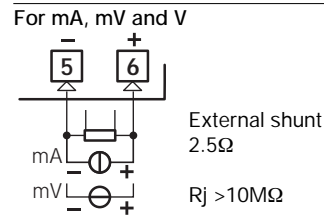
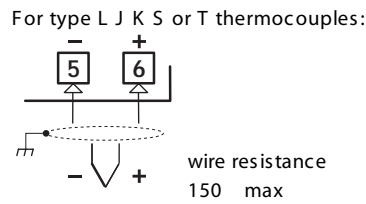

- For a 3-wire system, always use cables of the same diameter (1 mm² minimum.) (line 20 Ω/lead maximum resistance)
- For a 2-wire system, always use cables of the same diameter (1.5mm² min.) and put a jumper between terminals 5 and 6.

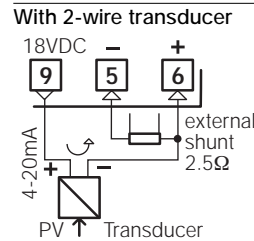
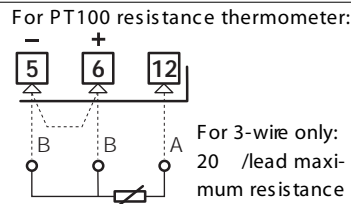

- When the distance between the controller and the sensor is 50 ft. (15 mt.), using cable of 1.5 mm² diameter, an error of approx. 2° F (1° C) is produced.

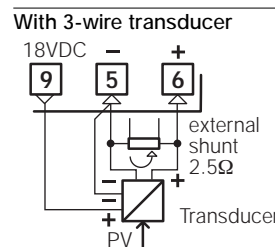
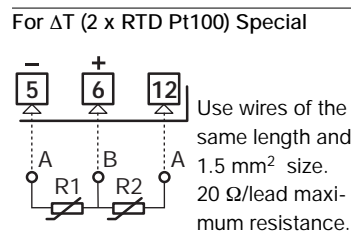

R1 + R2 must be < 320Ω

2.3.5 OP4 OUTPUT (option)



Process Variable (PV) retransmission:

- Galvanic isolation 500VAC/1 min.
- 0/4-20mA, 750Ω/ 15V. max.

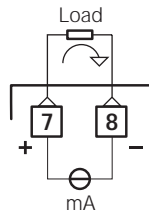

2.3.6 SERIAL COMMUNICATIONS (option)



- Galvanic isolation 500VAC/1 min
- Compliance to the EIA RS485 standard for Modbus/Jbus

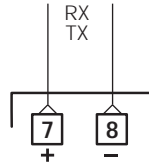

⚠ Please, read the user instructions on the "C1 controller MODBUS/JBUS protocol."

2.3.5 OP4 OUTPUT (option)



Process Variable (PV) retransmission:

- Galvanic isolation 500VAC/1 min.
- 0/4-20mA, 750Ω/ 15V. max.

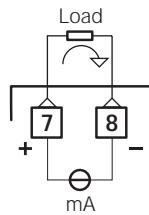

2.3.6 SERIAL COMMUNICATIONS (option)



- Galvanic isolation 500VAC/1 min
- Compliance to the EIA RS485 standard for Modbus/Jbus

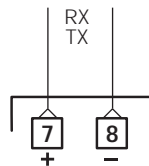

⚠ Please, read the user instructions on the "C1 controller MODBUS/JBUS protocol."

3 Nomenclature

The complete code is shown on the instrument label.
This information is accessible from the front panel by means of the procedure described in section 4.2.2, page 19.

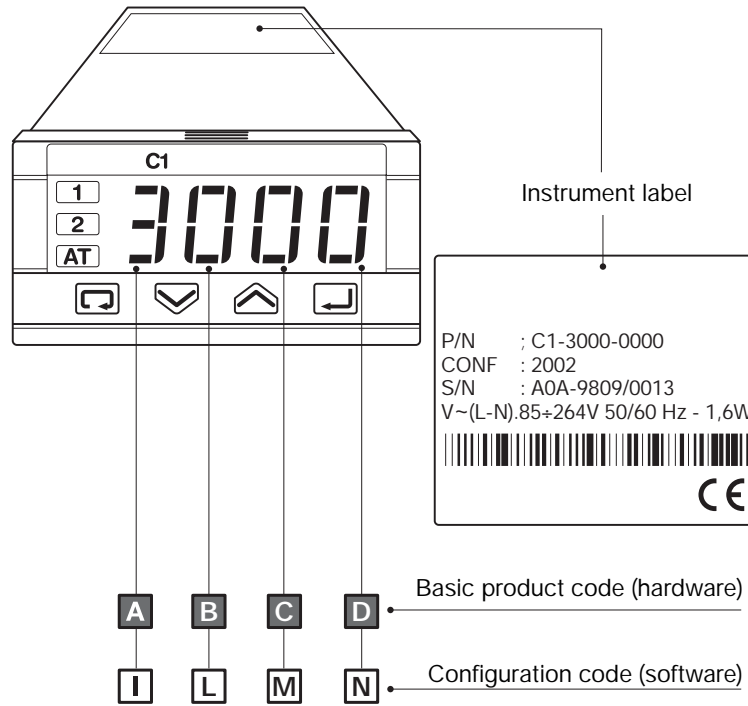

3 Nomenclature

The complete code is shown on the instrument label.
This information is accessible from the front panel by means of the procedure described in section 4.2.2, page 19.

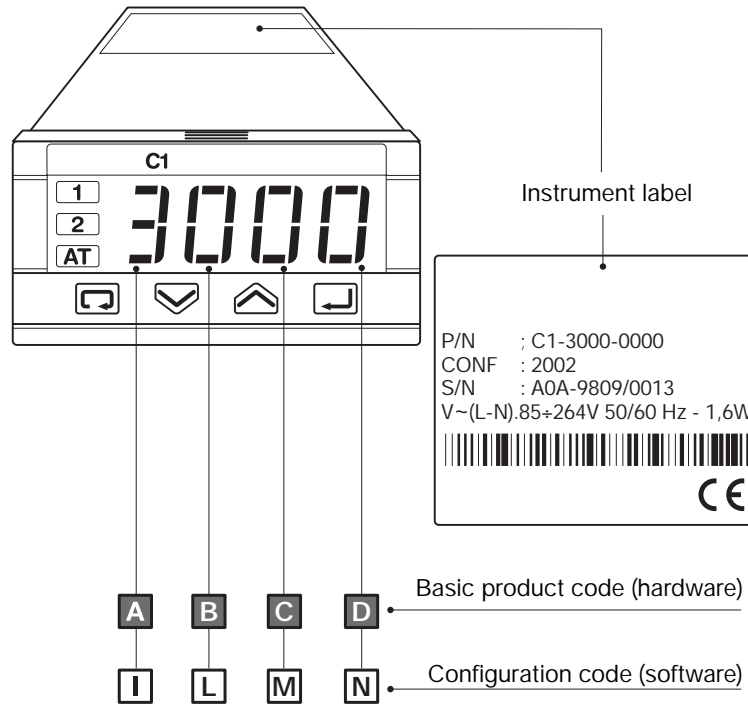

3.1 MODEL CODE

The product code indicates the specific hardware configuration of the instrument. It cannot be modified in the field.

Model: **C 1** **A B C D** - **0 F G 0** / **I L M N**

Line		C	D
Power supply		A	
100 - 240VAC (- 15% + 10%)		3	
24VAC (- 25% + 12%) or 24V- (- 15% + 25%)		5	
OP1 Output		B	
Relay		0	
Triac		3	
Serial Communications	Options	C	D
Not supplied	None	0	0
	Transmitter Power Supply (P.S.)	0	6
	Transmitter P.S. + Retransmission	0	7
RS485	None	5	0
Modbus/Jbus protocol	Transmitter Power Supply	5	6
User manual		F	
Italian/English (std.)		0	
French/English		1	
German/English		2	
Spanish/English		3	
Front panel colour		G	
Dark (std)		0	
Beige		1	

15

3.1 MODEL CODE

The product code indicates the specific hardware configuration of the instrument. It cannot be modified in the field.

Model: **C 1** **A B C D** - **0 F G 0** / **I L M N**

Line		C	D
Power supply		A	
100 - 240VAC (- 15% + 10%)		3	
24VAC (- 25% + 12%) or 24V- (- 15% + 25%)		5	
OP1 Output		B	
Relay		0	
Triac		3	
Serial Communications	Options	C	D
Not supplied	None	0	0
	Transmitter Power Supply (P.S.)	0	6
	Transmitter P.S. + Retransmission	0	7
RS485	None	5	0
Modbus/Jbus protocol	Transmitter Power Supply	5	6
User manual		F	
Italian/English (std.)		0	
French/English		1	
German/English		2	
Spanish/English		3	
Front panel colour		G	
Dark (std)		0	
Beige		1	

15

3.2 CONFIGURATION CODE

The configuration code consists of 4 digits that identify the operating characteristics of the unit, selected by the user.
See Section 4.5 on page 26 for instructions on how to set a new configuration code.

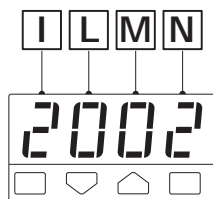

The configuration code can be displayed on the front panel, following the instructions on page 19, section 4.2.2.

Input type and range	C	F	I
TR Pt100 IEC751	-99.9-300.0 C	-99.9-572.9 F	0
TR Pt100 IEC751	-200-600 C	-328-1112 F	1
TC L Fe-Const DIN43710	0-600 C	32-1112 F	2
TC J Fe-Cu45% Ni IEC584	0-600 C	32-1112 F	3
TC T Cu-CuNi	-200-400 C	-328-752 F	4
TC K Chromel -Alumel IEC584	0-1200 C	32-2192 F	5
TC S Pt10%Rh-Pt IEC584	0-1600 C	32-2912 F	6
DC input 0-50 mV, linear	engineering units		7
DC input 10-50 mV, linear	engineering units		8
Custom input and range			9

Control mode	Output configuration	L
P.I.D.	Control OP1 / alarm AL2 on OP2	0
	Control OP2 / alarm AL2 on OP1	1
On - Off	Control OP1 / alarm AL2 on OP2	2
	Control OP2 / alarm AL2 on OP1	3
2 alarms indicator	Alarm AL1 on OP1/ alarm AL2 on OP2	4
	Alarm AL1 on OP2/ alarm AL2 on OP1	5

Type of control and safety	M
Reverse (AL1 active low) Safety 0%	0
Direct (AL1 active high) Safety 0%	1
Reverse (AL1 active low) Safety 100%	2
Direct (AL1 active high) Safety 100%	3

3.2 CONFIGURATION CODE

The configuration code consists of 4 digits that identify the operating characteristics of the unit, selected by the user.
See Section 4.5 on page 26 for instructions on how to set a new configuration code.

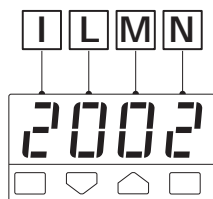

The configuration code can be displayed on the front panel, following the instructions on page 19, section 4.2.2.

Input type and range	C	F	I
TR Pt100 IEC751	-99.9-300.0 C	-99.9-572.9 F	0
TR Pt100 IEC751	-200-600 C	-328-1112 F	1
TC L Fe-Const DIN43710	0-600 C	32-1112 F	2
TC J Fe-Cu45% Ni IEC584	0-600 C	32-1112 F	3
TC T Cu-CuNi	-200-400 C	-328-752 F	4
TC K Chromel -Alumel IEC584	0-1200 C	32-2192 F	5
TC S Pt10%Rh-Pt IEC584	0-1600 C	32-2912 F	6
DC input 0-50 mV, linear	engineering units		7
DC input 10-50 mV, linear	engineering units		8
Custom input and range			9

Control mode	Output configuration	L
P.I.D.	Control OP1 / alarm AL2 on OP2	0
	Control OP2 / alarm AL2 on OP1	1
On - Off	Control OP1 / alarm AL2 on OP2	2
	Control OP2 / alarm AL2 on OP1	3
2 alarms indicator	Alarm AL1 on OP1/ alarm AL2 on OP2	4
	Alarm AL1 on OP2/ alarm AL2 on OP1	5

Type of control and safety	M
Reverse (AL1 active low) Safety 0%	0
Direct (AL1 active high) Safety 0%	1
Reverse (AL1 active low) Safety 100%	2
Direct (AL1 active high) Safety 100%	3

3.2 CONFIGURATION CODE

The configuration code consists of 4 digits that identify the operating characteristics of the unit, selected by the user. See Section 4.5 on page 26 for instructions on how to set a new configuration code.

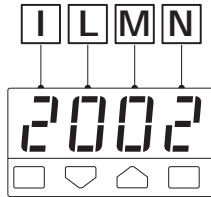

The configuration code can be displayed on the front panel, following the instructions on page 19, section 4.2.2.

Input type and range	C	F	I
TR Pt100 IEC751	-99.9-300.0 C	-99.9-572.9 F	0
TR Pt100 IEC751	-200-600 C	-328-1112 F	1
TC L Fe-Const DIN43710	0-600 C	32-1112 F	2
TC J Fe-Cu45% Ni IEC584	0-600 C	32-1112 F	3
TC T Cu-CuNi	-200-400 C	-328-752 F	4
TC K Chromel -Alumel IEC584	0-1200 C	32-2192 F	5
TC S Pt10%Rh-Pt IEC584	0-1600 C	32-2912 F	6
DC input 0-50 mV, linear	engineering units		7
DC input 10-50 mV, linear	engineering units		8
Custom input and range			9

Control mode	Output configuration	L
P.I.D.	Control OP1 / alarm AL2 on OP2	0
	Control OP2 / alarm AL2 on OP1	1
On - Off	Control OP1 / alarm AL2 on OP2	2
	Control OP2 / alarm AL2 on OP1	3
2 alarms indicator	Alarm AL1 on OP1/ alarm AL2 on OP2	4
	Alarm AL1 on OP2/ alarm AL2 on OP1	5

Type of control and safety		M
Reverse (AL1 active low)	Safety 0%	0
Direct (AL1 active high)	Safety 0%	1
Reverse (AL1 active low)	Safety 100%	2
Direct (AL1 active high)	Safety 100%	3

3.2 CONFIGURATION CODE

The configuration code consists of 4 digits that identify the operating characteristics of the unit, selected by the user. See Section 4.5 on page 26 for instructions on how to set a new configuration code.

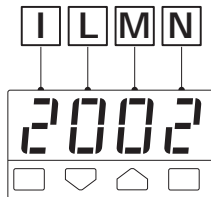

The configuration code can be displayed on the front panel, following the instructions on page 19, section 4.2.2.

Input type and range	C	F	I
TR Pt100 IEC751	-99.9-300.0 C	-99.9-572.9 F	0
TR Pt100 IEC751	-200-600 C	-328-1112 F	1
TC L Fe-Const DIN43710	0-600 C	32-1112 F	2
TC J Fe-Cu45% Ni IEC584	0-600 C	32-1112 F	3
TC T Cu-CuNi	-200-400 C	-328-752 F	4
TC K Chromel -Alumel IEC584	0-1200 C	32-2192 F	5
TC S Pt10%Rh-Pt IEC584	0-1600 C	32-2912 F	6
DC input 0-50 mV, linear	engineering units		7
DC input 10-50 mV, linear	engineering units		8
Custom input and range			9

Control mode	Output configuration	L
P.I.D.	Control OP1 / alarm AL2 on OP2	0
	Control OP2 / alarm AL2 on OP1	1
On - Off	Control OP1 / alarm AL2 on OP2	2
	Control OP2 / alarm AL2 on OP1	3
2 alarms indicator	Alarm AL1 on OP1/ alarm AL2 on OP2	4
	Alarm AL1 on OP2/ alarm AL2 on OP1	5

Type of control and safety		M
Reverse (AL1 active low)	Safety 0%	0
Direct (AL1 active high)	Safety 0%	1
Reverse (AL1 active low)	Safety 100%	2
Direct (AL1 active high)	Safety 100%	3



If, when the controller is powered up for the first time, the display shows the following message



it means that the controller has not been configured yet.

The controller remains in stand-by until the configuration code is set correctly (see chapter 4.6 page 26).

Alarm 2 type and function		N
Not active		0
Sensor break alarm		1
Absolute	active high	2
	active low	3
Deviation [1]	active high	4
	active low	5
Deviation	active out (of the band)	6
band [1]	active in (the band)	7

Note:

[1] Choice not available when the controller has been configured as 2-alarm indicator (L digit assigned to 4 or 5)

17



If, when the controller is powered up for the first time, the display shows the following message



it means that the controller has not been configured yet.

The controller remains in stand-by until the configuration code is set correctly (see chapter 4.6 page 26).

Alarm 2 type and function		N
Not active		0
Sensor break alarm		1
Absolute	active high	2
	active low	3
Deviation [1]	active high	4
	active low	5
Deviation	active out (of the band)	6
band [1]	active in (the band)	7

Note:

[1] Choice not available when the controller has been configured as 2-alarm indicator (L digit assigned to 4 or 5)

17

4 OPERATIONS

4.1 KEYPAD COMMANDS AND DISPLAY

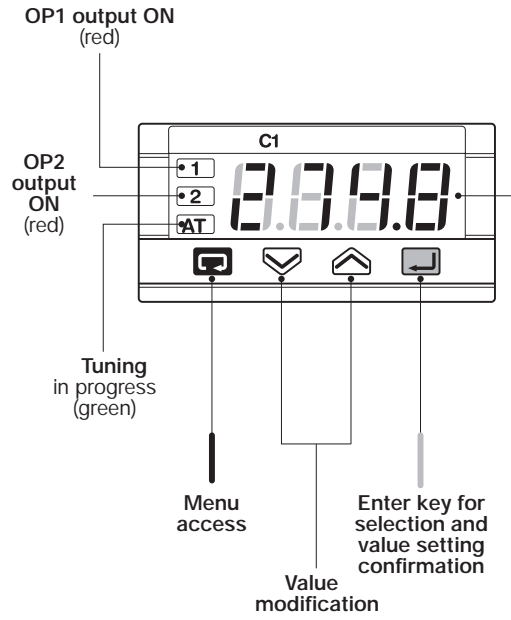

- **PV control input (operator mode)** (in engineering units) when the measured value is greater than sensor high range:
 0000
- when the measured value is less than the sensor low range:
 0000
- **Code and/or value of the Parameter (programming mode)**

4 OPERATIONS

4.1 KEYPAD COMMANDS AND DISPLAY

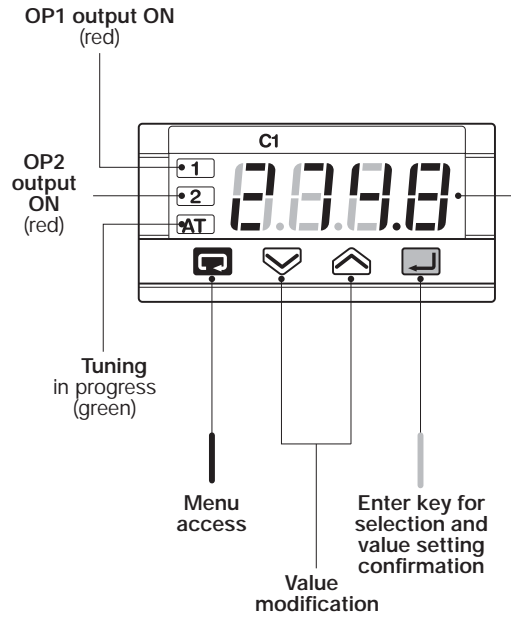

- **PV control input (operator mode)** (in engineering units) when the measured value is greater than sensor high range:
 0000
- when the measured value is less than the sensor low range:
 0000
- **Code and/or value of the Parameter (programming mode)**

4.2 DISPLAY MODE

When the display mode is selected, the unit automatically displays the most important parameters and configuration information.

In display mode, the parameter values cannot be modified by the user.

After 2 seconds in display mode, the display flashes and the unit returns to normal operating mode.

Note

[1] See table page 27

[2] This display is not presented if the instrument has been configured as an On - Off controller

4.2.1 DISPLAY OF THE PROCESS VARIABLES

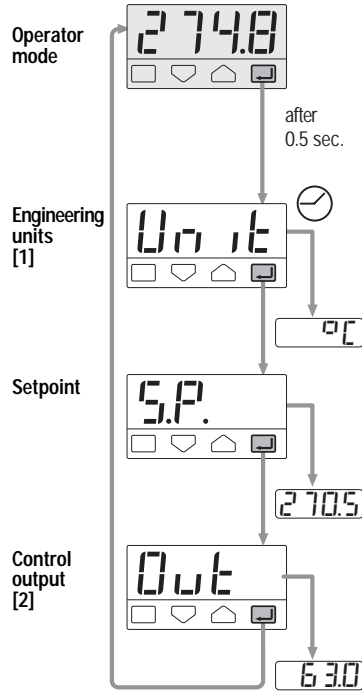

4.2.2 DISPLAY OF THE CONFIGURATION CODES

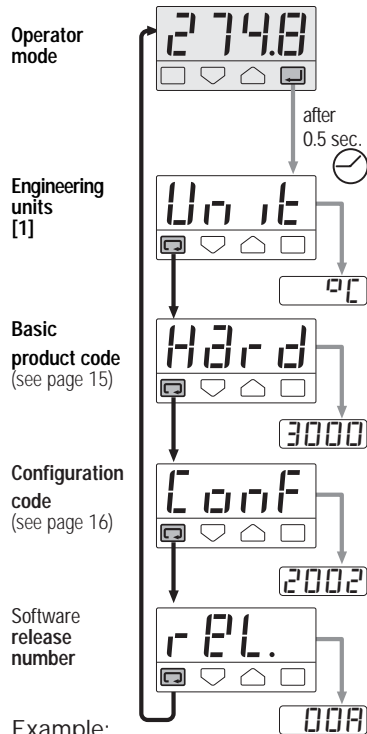

Example:
C1 - 3000 - 2002 / Release 00A

4.2 DISPLAY MODE

When the display mode is selected, the unit automatically displays the most important parameters and configuration information.

In display mode, the parameter values cannot be modified by the user.

After 2 seconds in display mode, the display flashes and the unit returns to normal operating mode.

Note

[1] See table page 27

[2] This display is not presented if the instrument has been configured as an On - Off controller

4.2.1 DISPLAY OF THE PROCESS VARIABLES

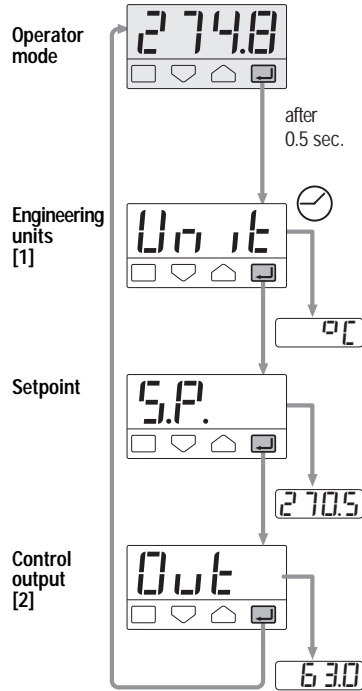

4.2.2 DISPLAY OF THE CONFIGURATION CODES

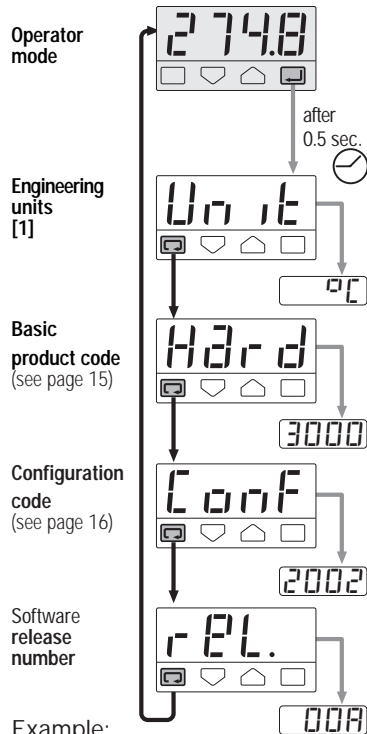





Example:
C1 - 3000 - 2002 / Release 00A

4.3 SETTING PARAMETERS

4.3.1 NUMERIC ENTRY

(Ex: change the value of a stored Setpoint from 275.0 to 240.0)



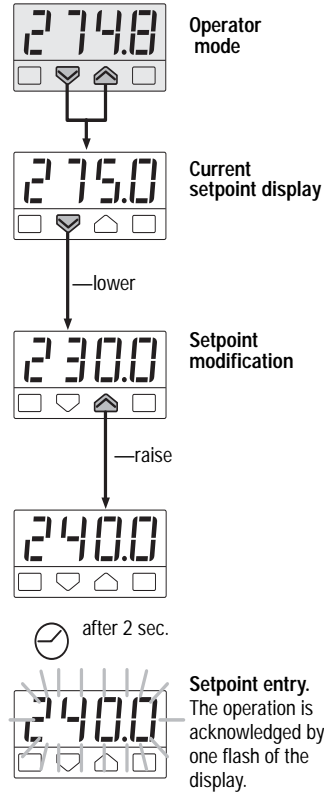

Press  or  momentarily to change the value by 1 unit every push.
 Continued pressing of  or  changes the value at rate that doubles every second. Releasing the button decreases the rate of change.
 In any case, the change of the value stops when it has reached the max/min limit set for the parameter.



4.3 SETTING PARAMETERS

4.3.1 NUMERIC ENTRY



(Ex: change the value of a stored Setpoint from 275.0 to 240.0)

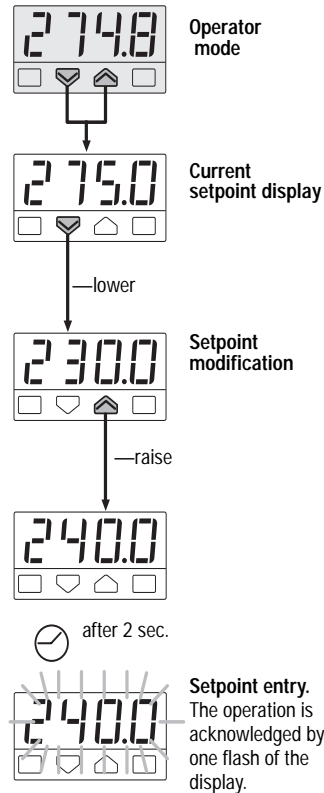

Press  or  momentarily to change the value by 1 unit every push.
 Continued pressing of  or  changes the value at rate that doubles every second. Releasing the button decreases the rate of change.
 In any case, the change of the value stops when it has reached the max/min limit set for the parameter.



4.3.2 SETTING MNEMONIC CODES

(see Configuration, pages 26, 27)

Press the  or  to display the next or previous mnemonic for the selected parameter.

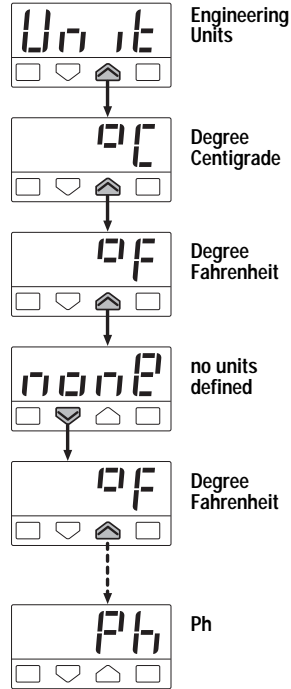

Continued pressing of  or  will display further mnemonics at a rate of one mnemonic every 0.5 sec. The mnemonic displayed at the time the next parameter is selected, is the one stored in the parameter.





21

4.3.2 SETTING MNEMONIC CODES

(see Configuration, pages 26, 27)

Press the  or  to display the next or previous mnemonic for the selected parameter.

Continued pressing of  or  will display further mnemonics at a rate of one mnemonic every 0.5 sec. The mnemonic displayed at the time the next parameter is selected, is the one stored in the parameter.

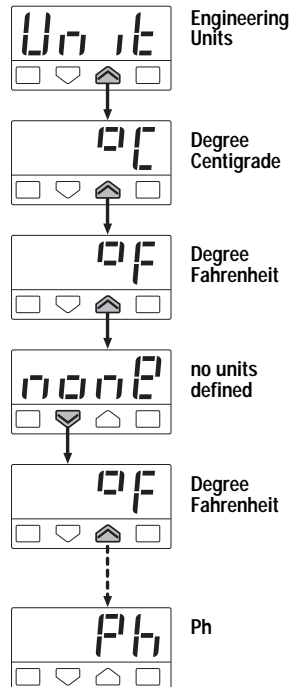

21

4.4 SETTING PARAMETERS

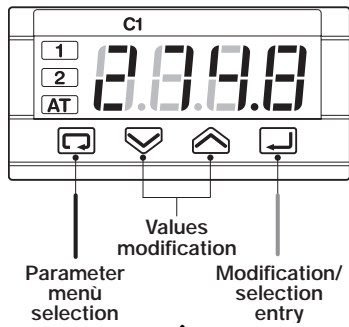

The parameter setting procedure has a timeout. If no keys are pressed for 30 seconds, the controller switches back, automatically, to the operator mode.

After having selected the parameter or the code, press and to display or modify the value (see page 20). The value is entered when the next parameter is selected, by pressing the key.

Pressing the key, the next group of parameters is presented on the display.

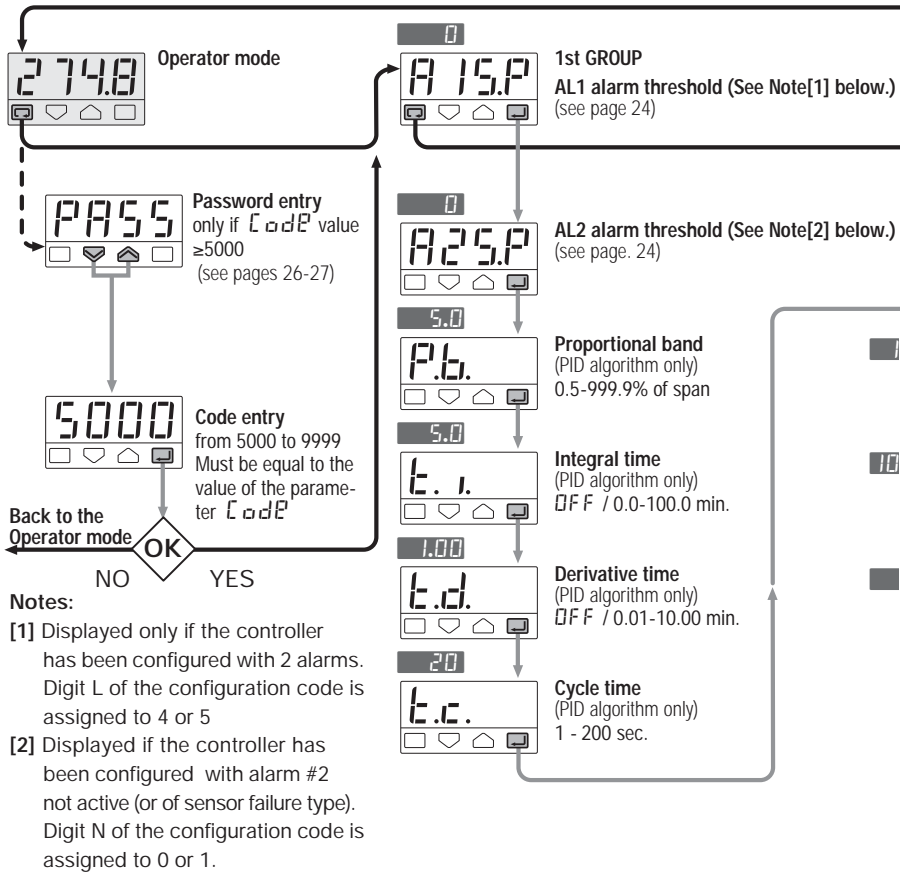

4.4 SETTING PARAMETERS

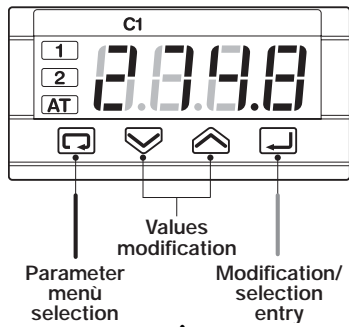

The parameter setting procedure has a timeout. If no keys are pressed for 30 seconds, the controller switches back, automatically, to the operator mode.

After having selected the parameter or the code, press and to display or modify the value (see page 20). The value is entered when the next parameter is selected, by pressing the key.

Pressing the key, the next group of parameters is presented on the display.

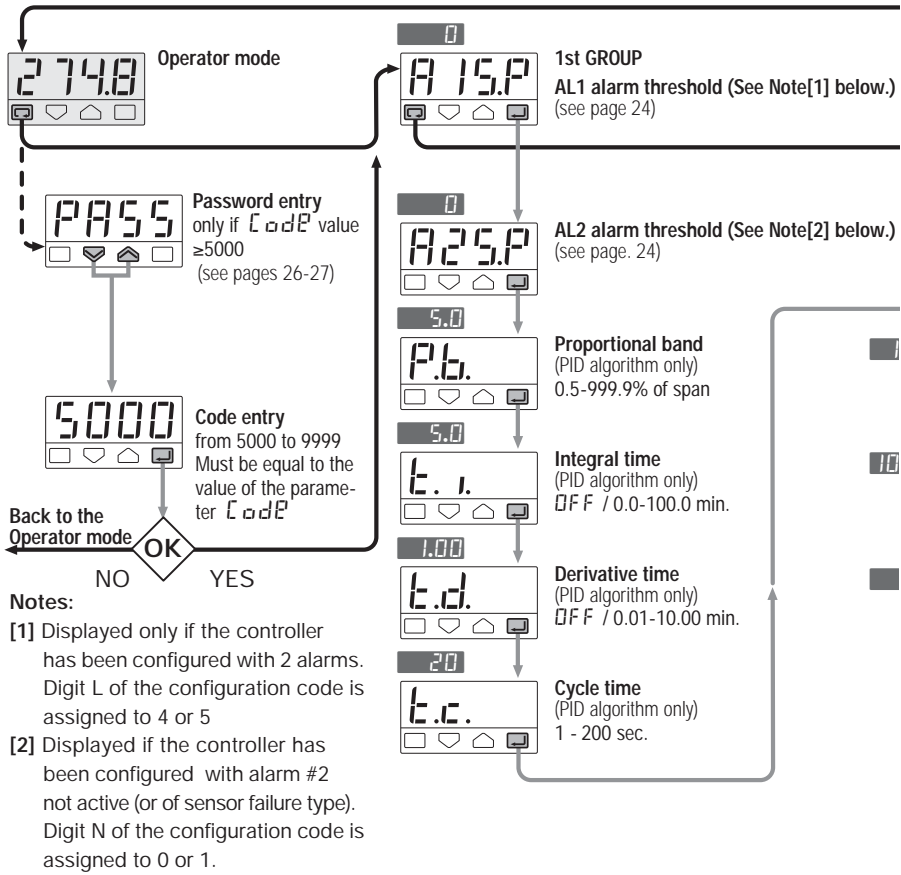

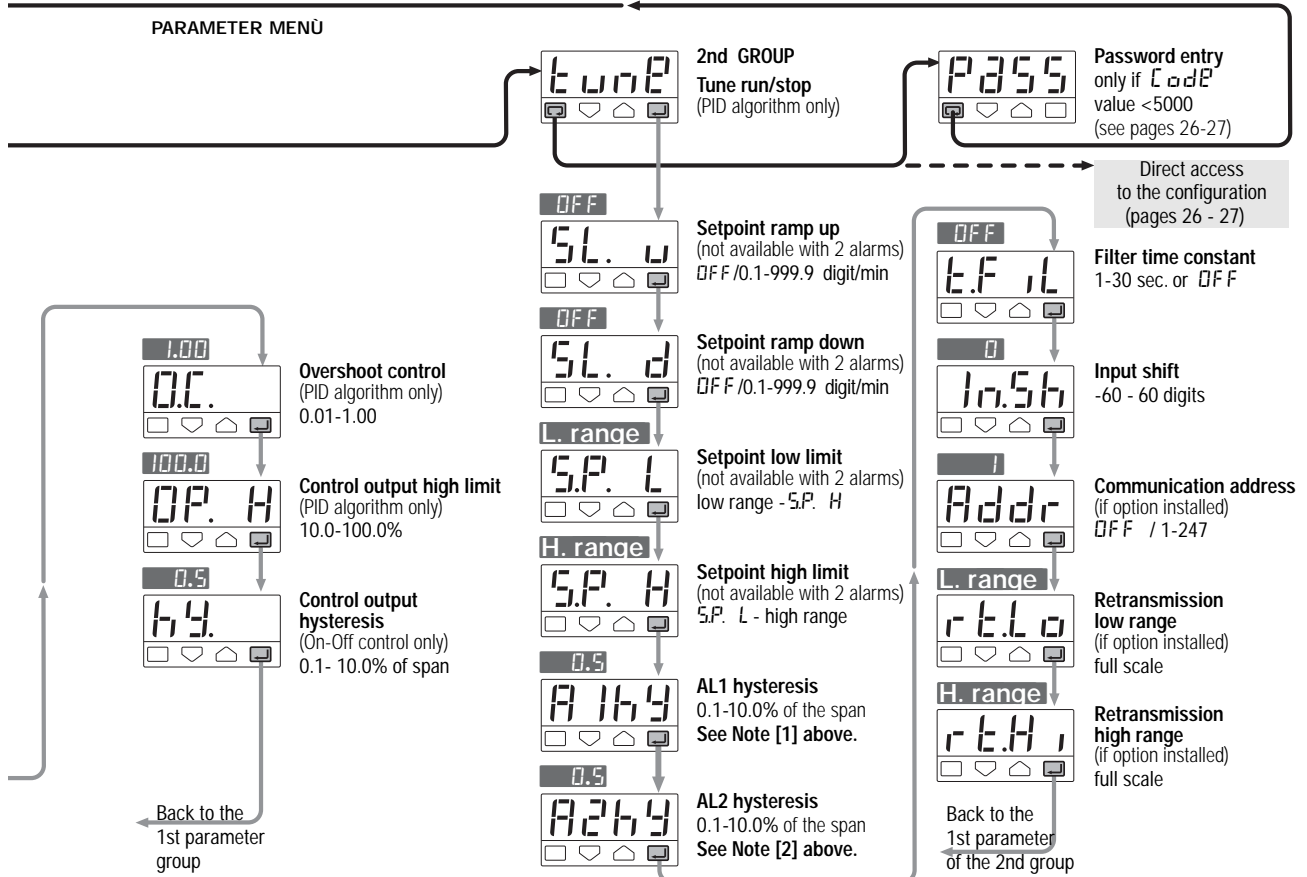
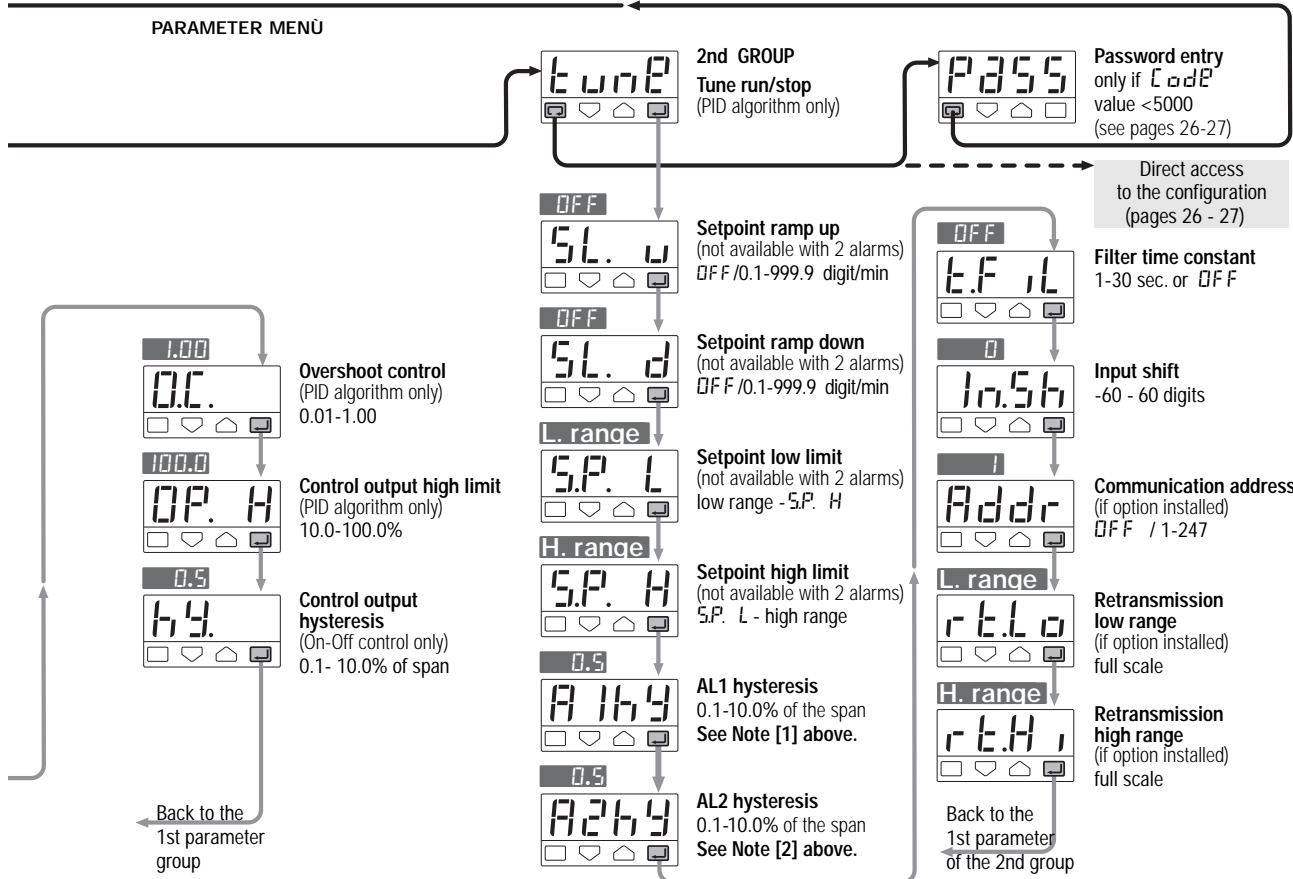

4.5 PARAMETER

1st GROUP

The controller parameters have been organized in group, according to their functionality area.

A15P AL1 alarm set point

This set point is displayed only if the controller has been configured with 2 alarms. (Digit L of the configuration code assigned to 4 or 5)

A25P AL2 alarm set point

The alarm occurrences handle the OP1 and OP2 outputs, in different ways, according to the configured types of alarms, as illustrated.

Pb. Proportional band

This parameter specifies the proportional band coefficient that multiplies the error (SP - PV).

E. I. Integral time

The integral time value specifies

Sensor break or input disconnection

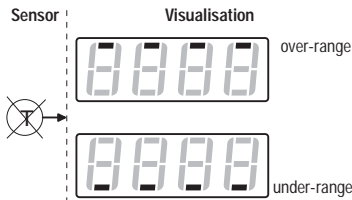

Absolute alarm (full scale)

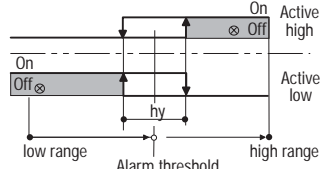

Deviation alarm

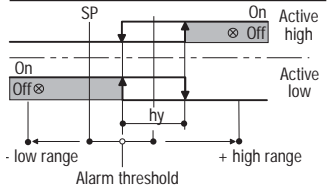

Band alarm

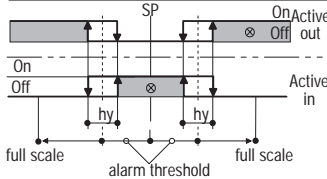

the time required by the integral term to generate an output equivalent to the proportional term. When *OFF* the integral term is not included in the control algorithm.

E.d. Derivative time

The derivative term coefficient specifies the time required by the proportional term P to reach the level of D. When *OFF* the derivative term is not included in the control algorithm.

E.c. Control output cycle time

The cycle time of the time proportioning control output. The PID control output is provided through the pulse width modulation of the digital waveform.

OC. Overshoot control

This parameter specifies the span of action of the overshoot control. Setting lower values (0.99 → 0.01) reduces the overshoot resulting from a set point change. The overshoot control does not affect the

4.5 PARAMETER

1st GROUP

The controller parameters have been organized in group, according to their functionality area.

A15P AL1 alarm set point

This set point is displayed only if the controller has been configured with 2 alarms. (Digit L of the configuration code assigned to 4 or 5)

A25P AL2 alarm set point

The alarm occurrences handle the OP1 and OP2 outputs, in different ways, according to the configured types of alarms, as illustrated.

Pb. Proportional band

This parameter specifies the proportional band coefficient that multiplies the error (SP - PV).

E. I. Integral time

The integral time value specifies

Sensor break or input disconnection

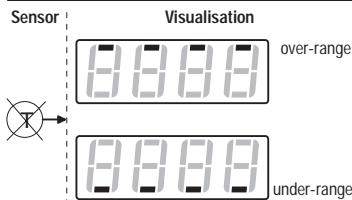

Absolute alarm (full scale)

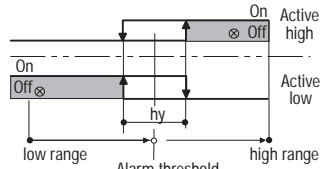

Deviation alarm

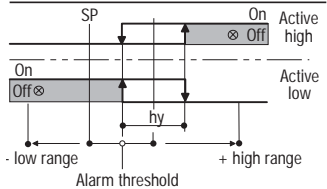

Band alarm

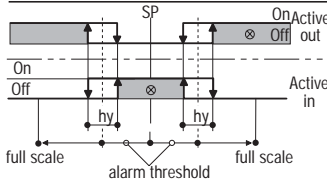

the time required by the integral term to generate an output equivalent to the proportional term. When *OFF* the integral term is not included in the control algorithm.

E.d. Derivative time

The derivative term coefficient specifies the time required by the proportional term P to reach the level of D. When *OFF* the derivative term is not included in the control algorithm.

E.c. Control output cycle time

The cycle time of the time proportioning control output. The PID control output is provided through the pulse width modulation of the digital waveform.

OC. Overshoot control

This parameter specifies the span of action of the overshoot control. Setting lower values (0.99 → 0.01) reduces the overshoot resulting from a set point change. The overshoot control does not affect the

effectiveness of the PID algorithm.
Set 1 to disable the overshoot control.

OP. H Control output high limit

Specifies the maximum value the control output can be set.

69. Control output hysteresis

Hysteresis of the threshold

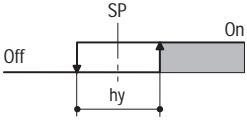

Control output hysteresis span, set in % of the full scale.

2nd GROUP

SL. u Setpoint ramp up

SL. d Setpoint ramp down

This parameter specifies the maximum rate of change of the set point in digit/min. When the parameter is $\square F F$, this function is disabled.

SP. L Set point low limit

Low limit of the setpoint value. When the parameter is $\square F F$, this function is disabled.

SP. H Set point high limit

High limit of the set point value. When the parameter is $\square F F$, this function is disabled.

A169 AL1 alarm hysteresis

A269 AL2 alarm hysteresis

Hysteresis of the threshold of both the alarms, that activate OP1 and OP2 control output. It is specified as a % of the full scale.

EF. IL Input filter time constant

Time constant, in seconds, of the RC input filter applied to the PV input. When this parameter is set to $\square F F$ the filter is bypassed.

Filter response

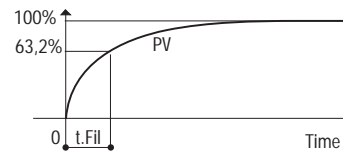

10.56 Input shift

This value is added to the measured PV input value. Its effect is to shift the whole PV scale of up to ± 60 digits.

Addr Controller address

the address range is from 1 to 247 and must be unique for each controller on the communication bus to the supervisor.

When set to $\square F F$ the controller is not communicating

re.LO Retransmission low range

re.HI Retransmission high range

These parameters define the range of the OP4 retransmission output. Example: 4-20 mA output corresponding to 20-120 C.

25

effectiveness of the PID algorithm.
Set 1 to disable the overshoot control.

OP. H Control output high limit

Specifies the maximum value the control output can be set.

69. Control output hysteresis

Hysteresis of the threshold

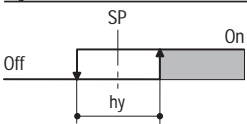

Control output hysteresis span, set in % of the full scale.

2nd GROUP

SL. u Setpoint ramp up

SL. d Setpoint ramp down

This parameter specifies the maximum rate of change of the set point in digit/min. When the parameter is $\square F F$, this function is disabled.

SP. L Set point low limit

Low limit of the setpoint value. When the parameter is $\square F F$, this function is disabled.

SP. H Set point high limit

High limit of the set point value. When the parameter is $\square F F$, this function is disabled.

A169 AL1 alarm hysteresis

A269 AL2 alarm hysteresis

Hysteresis of the threshold of both the alarms, that activate OP1 and OP2 control output. It is specified as a % of the full scale.

EF. IL Input filter time constant

Time constant, in seconds, of the RC input filter applied to the PV input. When this parameter is set to $\square F F$ the filter is bypassed.

Filter response

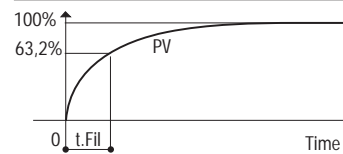

10.56 Input shift

This value is added to the measured PV input value. Its effect is to shift the whole PV scale of up to ± 60 digits.

Addr Controller address

the address range is from 1 to 247 and must be unique for each controller on the communication bus to the supervisor.

When set to $\square F F$ the controller is not communicating

re.LO Retransmission low range

re.HI Retransmission high range

These parameters define the range of the OP4 retransmission output. Example: 4-20 mA output corresponding to 20-120 C.

25

4.6 CONFIGURATION

The configuration of the controller is specified through a 4 digit code that defines the type of input, of control output and of the alarms. (sect. 3.2 page 16)

Other parameters specify the type of auxiliary functions.

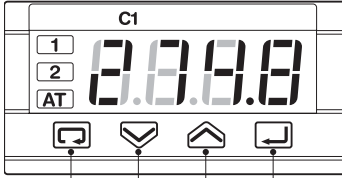

Parameter menu selection
Value modification
Modification/selection entry

Press or to display the next parameter or the next code and change its value.

The new value is stored in the controller when the next parameter is selected by pressing .

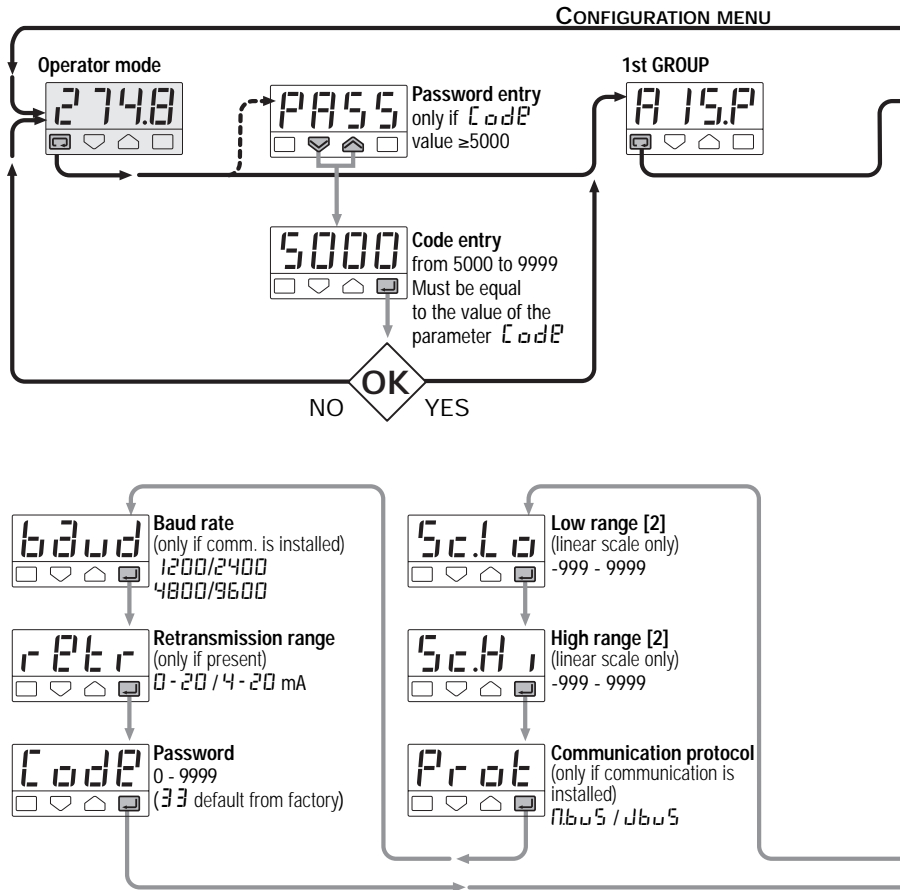

4.6 CONFIGURATION

The configuration of the controller is specified through a 4 digit code that defines the type of input, of control output and of the alarms. (sect. 3.2 page 16)

Other parameters specify the type of auxiliary functions.

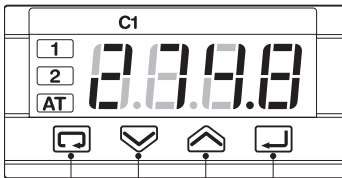

Parameter menu selection
Value modification
Modification/selection entry

Press or to display the next parameter or the next code and change its value.

The new value is stored in the controller when the next parameter is selected by pressing .

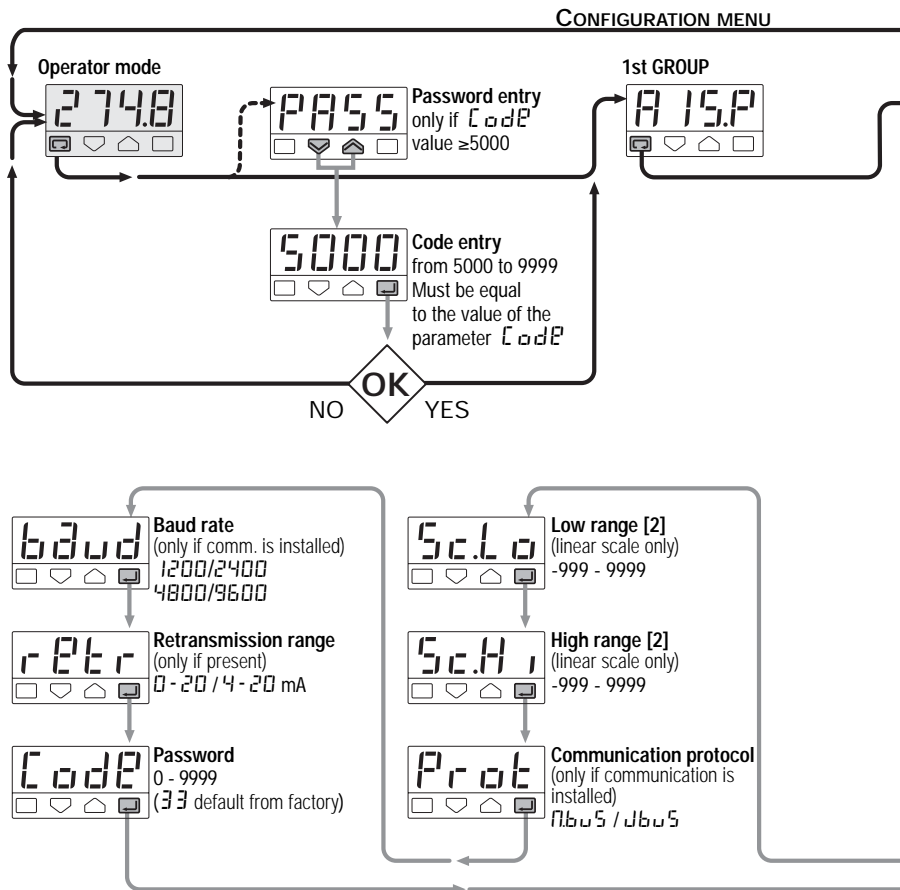

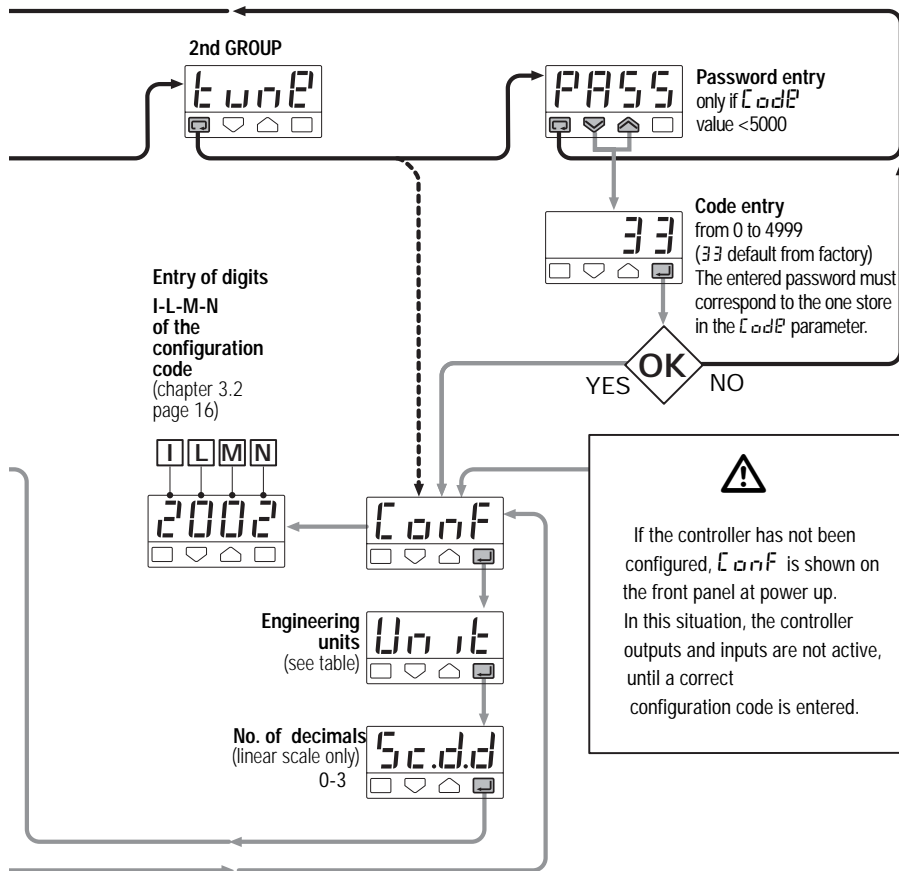

Note
Pressing the displays the next group of parameters.

[1] Table of supported Engineering Units.

Celsius degrees *	°C
Fahrenheit degrees *	°F
none	none
mV	mV
Volt	V
mA	mA
Ampere	A
Bar	bar
PSI	PSI
Rh	rh
pH	pH

* For inputs from thermocouple or resistance thermometer, the choice is between °C and °F only.

[2] Range of min 100 digits.

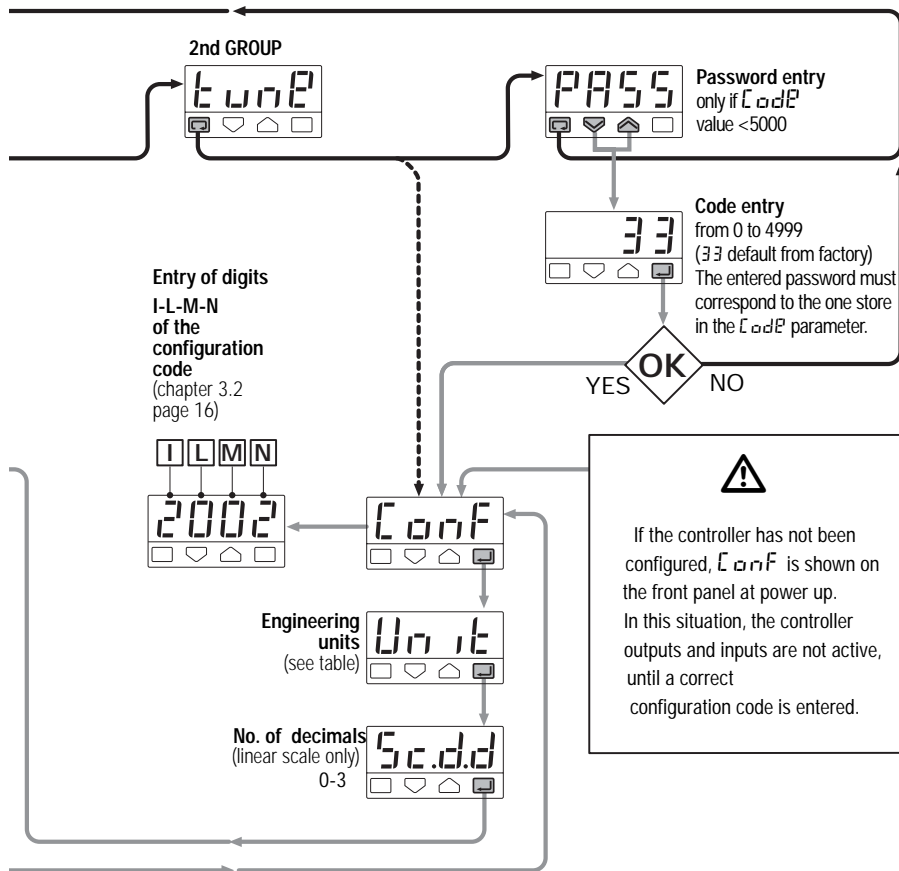

Note
Pressing the displays the next group of parameters.

[1] Table of supported Engineering Units.

Celsius degrees *	°C
Fahrenheit degrees *	°F
none	none
mV	mV
Volt	V
mA	mA
Ampere	A
Bar	bar
PSI	PSI
Rh	rh
pH	pH

* For inputs from thermocouple or resistance thermometer, the choice is between °C and °F only.

[2] Range of min 100 digits.

5 AUTOMATIC TUNING

Start/stop of the Fuzzy Tuning
The Tuning operation can be started or stopped any time.

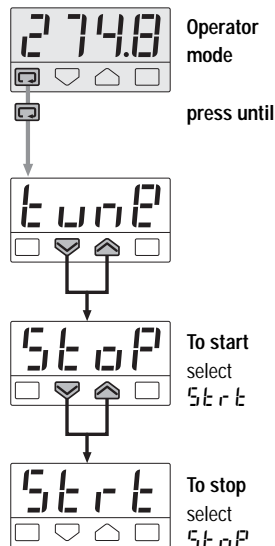

The green led **AT** comes on when Fuzzy Tuning is in progress. At the end of this operation, the calculated PID parameters are stored and used by the control algorithm, and the controller returns to the operator mode. The green led **AT** goes off.

This function allows the calculation of the optimal PID parameters to monitor the response of the process to disturbances.

The controller provides 2 types of "one shot" tuning algorithm that are selected automatically according to the process condition when the operation is started.

Step response tuning:

This type is selected when, at the start of the autotune operation, the process variable (PV) is more than 5% of the span away from set point (SP). The big advantage of this method is fast calculation, with reasonably accurate results.

Natural frequency tuning:

This type is selected when PV is close (within 5% of the span) to SP.

The advantage of this method is better accuracy in the term calculated and a reasonable speed of calculation.

Fuzzy Tuning automatically determines the best method to use to calculate the PID terms, according to process conditions.

Step response

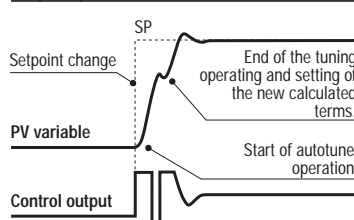

Natural frequency

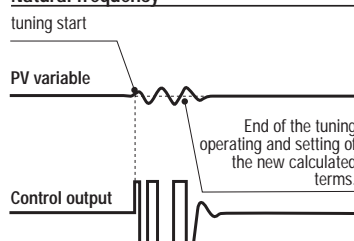

5 AUTOMATIC TUNING

Start/stop of the Fuzzy Tuning
The Tuning operation can be started or stopped any time.

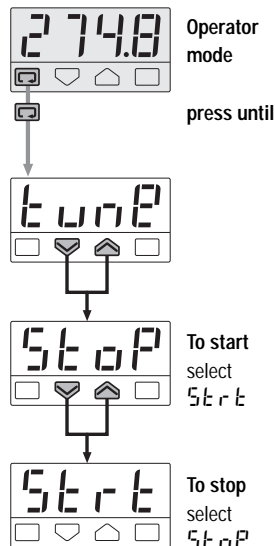

The green led **AT** comes on when Fuzzy Tuning is in progress. At the end of this operation, the calculated PID parameters are stored and used by the control algorithm, and the controller returns to the operator mode. The green led **AT** goes off.

This function allows the calculation of the optimal PID parameters to monitor the response of the process to disturbances.

The controller provides 2 types of "one shot" tuning algorithm that are selected automatically according to the process condition when the operation is started.

Step response tuning:

This type is selected when, at the start of the autotune operation, the process variable (PV) is more than 5% of the span away from set point (SP). The big advantage of this method is fast calculation, with reasonably accurate results.

Natural frequency tuning:

This type is selected when PV is close (within 5% of the span) to SP.

The advantage of this method is better accuracy in the term calculated and a reasonable speed of calculation.

Fuzzy Tuning automatically determines the best method to use to calculate the PID terms, according to process conditions.

Step response

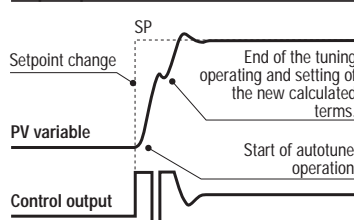

Natural frequency

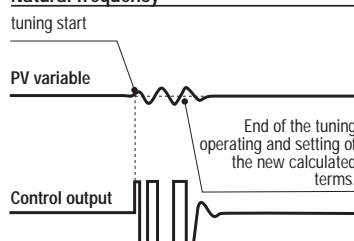

6 TECHNICAL SPECIFICATIONS

Features (at 77F (25C) ambient temp.)	Description			
Total configurability see: par. 3.2, page 16. par. 4.6, page 26.	From keypad or serial communication the user selects: the type of input - the associated functions and the corresponding outputs - the type of control algorithm - the type of output and the safe conditions - the type and functionality of the alarms - the values of all the control parameters.			
PV Input see pages 12 and 16.	Common characteristics	A/D converter with resolution of 50.000 points. Update measurement time: 0.2 second. Sampling time: 0.5 second. Input bias: -60 to +60 digits Input filter with enable/disable: 1 to 30 seconds.		
	Accuracy	0.25% ± 1 digit for temperature sensors. 0.1% ± 1 digit (for mV and mA).	Between 100-240 VAC the error is minimal.	
	Resistance thermometer	Pt100Ω at 0°C (IEC 751). °C/°F selectable.	2 or 3 wire connection.	Max. wire resistance: 20Ω max (3 wires) Sensitivity: 0.1°C/10°C Env. Temp. (0.18°F/18°F <0.1°C (0.18°F)/ 10Ω Wire Res.
	Thermocouple	Type L,J,T,K,S (IEC 584). °C/°F selectable.	Internal cold junction compensation in °C/°F.	Max. wire resistance: 150Ω max Sensitivity: <2μV/°C Env. Temp. <0.5μV / 10Ω Wire Res.
	DC input (current)	4 - 20mA, 0-20mA with external shunt 2.5Ω Rj >10MΩ	Engineering units Conf. decimal point position Init. Sc. -999 to 9999	Input drift: <0.1% / 20°C (36°F) ambient temp.
	DC input (voltage)	10-50mV, 0-50mV Rj >10MΩ	Full Sc. -999 to 9999 (min. range of 100 digits)	

29

6 TECHNICAL SPECIFICATIONS

Features (at 77F (25C) ambient temp.)	Description			
Total configurability see: par. 3.2, page 16. par. 4.6, page 26.	From keypad or serial communication the user selects: the type of input - the associated functions and the corresponding outputs - the type of control algorithm - the type of output and the safe conditions - the type and functionality of the alarms - the values of all the control parameters.			
PV Input see pages 12 and 16.	Common characteristics	A/D converter with resolution of 50.000 points. Update measurement time: 0.2 second. Sampling time: 0.5 second. Input bias: -60 to +60 digits Input filter with enable/disable: 1 to 30 seconds.		
	Accuracy	0.25% ± 1 digit for temperature sensors. 0.1% ± 1 digit (for mV and mA).	Between 100-240 VAC the error is minimal.	
	Resistance thermometer	Pt100Ω at 0°C (IEC 751). °C/°F selectable.	2 or 3 wire connection.	Max. wire resistance: 20Ω max (3 wires) Sensitivity: 0.1°C/10°C Env. Temp. (0.18°F/18°F <0.1°C (0.18°F)/ 10Ω Wire Res.
	Thermocouple	Type L,J,T,K,S (IEC 584). °C/°F selectable.	Internal cold junction compensation in °C/°F.	Max. wire resistance: 150Ω max Sensitivity: <2μV/°C Env. Temp. <0.5μV / 10Ω Wire Res.
	DC input (current)	4 - 20mA, 0-20mA with external shunt 2.5Ω Rj >10MΩ	Engineering units Conf. decimal point position Init. Sc. -999 to 9999	Input drift: <0.1% / 20°C (36°F) ambient temp.
	DC input (voltage)	10-50mV, 0-50mV Rj >10MΩ	Full Sc. -999 to 9999 (min. range of 100 digits)	

29

Features (at 77F (25C) ambient temp.)		Description	
Operating mode and Outputs	Indicator with 2 alarms	AL1 alarm	AL2 alarm
		OP1 - Relay or Triac	OP2 - SSR drive
	1 PID loop or 1 ON-OFF loop with 1 Alarm	Control output	AL2 alarm
		OP1 - Relay or Triac	OP2 - SSR drive
Control Mode	Algorithm	PID with overshoot control or ON OFF	
	Proportional band (P)	0.5 - 999.9%	
	Integral time (I)	0.1-100.0 min	Off = 0
	Derivative time (D)	0.01-10.00 min	
	Cycle time	1-200 sec	
	Overshoot control	0.01-1.00	
	High limit	100.0-10.0%	
	Hysteresis	0.1-10.0%	ON-OFF algorithm
OP1 output	SPST Relay N.O., 2A/250VAC for resistive load. Triac, 1A/250VAC for resistive load.		
OP2 output	SSR drive, not isolated: 5VDC, ± 10%, 30mA max.		
AL1 alarm (indicator with 2 alarms)	Hysteresis 0.1-10,0% full scale.		
	Active high	Absolute threshold, whole range.	
Active low			
AL2 alarm	Hysteresis 0.1-10,0% c.s.		
	Action	Activate high	Action type
			Deviation threshold ± range
		Activate low	Band threshold 0 - range
	Special function	Sensor failure	
Absolute threshold whole range			

Features (at 77F (25C) ambient temp.)		Description	
Operating mode and Outputs	Indicator with 2 alarms	AL1 alarm	AL2 alarm
		OP1 - Relay or Triac	OP2 - SSR drive
	1 PID loop or 1 ON-OFF loop with 1 Alarm	Control output	AL2 alarm
		OP1 - Relay or Triac	OP2 - SSR drive
Control Mode	Algorithm	PID with overshoot control or ON OFF	
	Proportional band (P)	0.5 - 999.9%	
	Integral time (I)	0.1-100.0 min	Off = 0
	Derivative time (D)	0.01-10.00 min	
	Cycle time	1-200 sec	
	Overshoot control	0.01-1.00	
	High limit	100.0-10.0%	
	Hysteresis	0.1-10.0%	ON-OFF algorithm
OP1 output	SPST Relay N.O., 2A/250VAC for resistive load. Triac, 1A/250VAC for resistive load.		
OP2 output	SSR drive, not isolated: 5VDC, ± 10%, 30mA max.		
AL1 alarm (indicator with 2 alarms)	Hysteresis 0.1-10,0% full scale.		
	Active high	Absolute threshold, whole range.	
Active low			
AL2 alarm	Hysteresis 0.1-10,0% c.s.		
	Action	Activate high	Action type
			Deviation threshold ± range
		Activate low	Band threshold 0 - range
	Special function	Sensor failure	
Absolute threshold whole range			

Features (at 77F (25C) ambient temp.)	Description	
Setpoint	Ramp up and down	0.1- 999.9 digit/min (Off = 0).
	Low limit	From low range to the high limit.
	High limit	From low limit to the high range.
OP4 PV retransmission (option)	Galvanic isolation: 500 VAC /1 min. Resolution 12 bit (0.025%). Accuracy: 0.1 %.	Current output: 4-20mA 750Ω/15V max.
One shot Fuzzy-Tuning with automatic selection	The controller automatically selects the best method according to the process conditions.	Step response. Natural frequency.
Serial comm. (option)	RS485 isolated, Modbus/Jbus protocol, 1200, 2400, 4800, 9600 bit/sec, 2-wire.	
Auxiliary Supply	+18VDC ±20%, 30mA max for an external transmitter supply.	
Operational safety	Measure input	Detection of "out of range", short circuit, or sensor failure with automatic activation of the safety strategies and alerts on display.
	Control output	Safety value: 0 to +100%. (user enabled/disabled).
	Parameters	parameter and configuration data are stored in nonvolatile memory for an unlimited time.
	Access protection	Password to access the configuration and parameter data.
General characteristics	Power supply	100 - 240VAC (- 15% + 10%) 50/60Hz. or 24VAC (- 25% + 12%) 50/60Hz and 24V- (- 15% + 25%). Power consumption: 1.6W max.
	Electric safety	Compliance to EN61010, installation class 2 (2500V) pollution class 2.
	Electromagnetic compatibility	Compliance to the CE standards for industrial system and equipment.
	Protection EN650529	IP20 termination unit. IP65 front panel.
	Dimensions	19" x .95", depth 4.72" (1/32 D IN - 48 x 24, depth 120 mm); 0.25 lbs. (100 gr.) approx.

Features (at 77F (25C) ambient temp.)	Description	
Setpoint	Ramp up and down	0.1- 999.9 digit/min (Off = 0).
	Low limit	From low range to the high limit.
	High limit	From low limit to the high range.
OP4 PV retransmission (option)	Galvanic isolation: 500 VAC /1 min. Resolution 12 bit (0.025%). Accuracy: 0.1 %.	Current output: 4-20mA 750Ω/15V max.
One shot Fuzzy-Tuning with automatic selection	The controller automatically selects the best method according to the process conditions.	Step response. Natural frequency.
Serial comm. (option)	RS485 isolated, Modbus/Jbus protocol, 1200, 2400, 4800, 9600 bit/sec, 2-wire.	
Auxiliary Supply	+18VDC ±20%, 30mA max for an external transmitter supply.	
Operational safety	Measure input	Detection of "out of range", short circuit, or sensor failure with automatic activation of the safety strategies and alerts on display.
	Control output	Safety value: 0 to +100%. (user enabled/disabled).
	Parameters	parameter and configuration data are stored in nonvolatile memory for an unlimited time.
	Access protection	Password to access the configuration and parameter data.
General characteristics	Power supply	100 - 240VAC (- 15% + 10%) 50/60Hz. or 24VAC (- 25% + 12%) 50/60Hz and 24V- (- 15% + 25%). Power consumption: 1.6W max.
	Electric safety	Compliance to EN61010, installation class 2 (2500V) pollution class 2.
	Electromagnetic compatibility	Compliance to the CE standards for industrial system and equipment.
	Protection EN650529	IP20 termination unit. IP65 front panel.
	Dimensions	19" x .95", depth 4.72" (1/32 D IN - 48 x 24, depth 120 mm); 0.25 lbs. (100 gr.) approx.