



SERIES F-09140 LINEAR ACTUATORS
FOR CLOSED OR OPEN LOOP APPLICATIONS
INSTRUCTION MANUAL F-09140.01

 **WARNING**

Do not operate or service this equipment before reading the operator's manual! Failure to do so could result in serious injury.



Alterations to hardware, wiring, or software must be approved in writing by Hays Cleveland, Division of UniControl Inc.

Your feedback is important to us! If you have comments about this document, please send them to salescombustion@unicontrolinc.com.

Revision Control

This manual is UniControl Inc. Document Number IM F-09140 Linear Actuator Instruction Manual.

Documentation Number and Revision Log	
MANUAL	REVISION DATE
F-09140.01	10/19/2009
HARDWARE	REVISION NUMBER
Linear Actuator	A0
SOFTWARE	REVISION NUMBER
NA	NA

Conventions

1. This manual pertains to the application of the F-09140 Linear Actuator to boiler plants. Other applications are possible.
2. Terminology (as defined by ASME CSD-1-1998 “Controls and Safety Devices for Automatically Fired Boilers”) that is used in this manual includes the following:
 - a. Control: a device designated to regulate the fuel, air, water, steam, or electrical supply to the controlled equipment. It may be automatic, semiautomatic, or manual.
 - b. Control, operating: an automatic control, other than a safety control, to start input, or regulate input upon satisfaction of demand.
 - c. Control, primary safety: a control directly responsive to flame properties, sensing the presence of flame and, in event of ignition failure or loss of flame, causing safety shutdown.
 - d. Control, safety (also known as limit): a control responsive to changes in liquid level, pressure, or temperature, which is set beyond the operating range to prevent operation beyond designed limits.

Abbreviations Used in This Manual

Term	Definition

Symbols Used in This Manual

The following symbols (if used in this manual) alert the operator to the conditions defined below.



Danger symbol indicates an imminently hazardous situation, which, if not avoided, will result in death or serious injury.



Warning symbol indicates a potentially hazardous situation, which, if not avoided, could result in death or serious injury.



Caution symbol indicates a potentially hazardous situation, which, if not avoided, could result in minor or moderate injury.

CAUTION

Caution used without the safety alert symbol indicates a potentially hazardous situation, which, if not avoided, may result in property damage.



Safety Warnings

Failure to comply in full with the following safety requirements may result in equipment damage, personal injury or death.

1. Read the entire manual to become familiar with the use and operation of this device.
2. Only qualified personnel should attempt to install, wire, commission, startup, service or operate this device.
3. This device is not suitable for use in an explosive ambient atmosphere.
4. Before working on this device, be sure that you understand the processes affected by this device completely.
5. Before working on this device, be sure that any process affected by this device is secure and safe for servicing.
6. Take appropriate precautions to avoid electric shock when working with this device near water.
7. Exercise caution while wiring or working on this device. Multiple voltage sources may be present: take appropriate precautions to avoid electric shock.
8. RFI (radio frequency interference) can affect adversely the operation of this device and devices that are connected together as a system. Do not use radios near this equipment: examples include, but are not limited to; citizen band radios (CB), walkie-talkies, transceivers, and amateur radios (HAM).



Wiring Tips

1. Remove all power from the unit before commencing any wiring operations. Wire with extreme caution!
2. All wiring must conform to the National Electrical Code and to local code regulations. Verify all electrical ratings on equipment.
3. Connecting high voltage to the low voltage circuits will damage the circuitry!
4. Mount the unit in such a manner that the wiring cable from the main electronics does not touch or approach any high magnetic sources such as motor starters, 3 ph. transformers, ignitors, etc. If mounted near a high magnetic source, electronic interference may cause the display to read incorrectly.

Storage, Handling & Unpacking

When unpacking this equipment, consult the packing list to be sure all items are present. Immediately report any missing items to the sales office where you ordered the equipment. If any part of the equipment has been damaged in transit, notify the carrier: damage claims for items shipped FOB the factory are negotiated with the carrier. Retain carton and packing materials for the claim adjuster's inspection. Retain the shipping carton for future use in case the equipment needs factory repair or calibration. The following components may be shipped individually. Specific purchase orders may include some or all of these items.

- F-09140 Linear Actuator
- Instruction Manual

Table of Contents

Revision Control	iii
Documentation Number and Revision Log.....	iii
Conventions	iii
Abbreviations Used in This Manual.....	iii
Symbols Used in This Manual.....	iii
Safety Warnings	iv
Wiring Tips.....	iv
Storage, Handling & Unpacking	iv
1.0 Introduction	
1.1 Description of Operation	1-1
1.2 Specifications	1-1
1.3 Nomenclature	1-3
2.0 Installation	
2.1 Mounting.....	2-1
2.2 Wiring	2-1
2.3 Actuator Linkage (Connection to Outlet Damper).....	2-1
3.0 Operation & Maintenance	
3.1 Operating Tips	3-1
3.2 Troubleshooting.....	3-1
3.3 Spare Parts	3-3
4.0 Customer Service Information	
4.1 Contacts	4-1
4.2 Repairs	4-1
4.3 Service	4-1
4.4 Standard Terms and Conditions of Sale.....	4-2

Illustrations & Drawings

Photographs 1 & 2, top: Hays Cleveland Series F-09140-010-1-A Linear Actuators are often used in draft control applications.	1-2
Photograph 3, bottom: A typical set of linkage for the F-09140 Actuator.	1-2
Figure 1: F-09140 Linear Actuator Linkage Dimensions.....	1-3
Figure 2, top left: Damper travel adjustments.....	2-2
Figure 3, top right: Typical vertical linkage arrangement.	2-2
Figure 4, center left: Typical horizontal linkage arrangement.	2-2
Figure 5, bottom: Suggested actuator locations.	2-2
Table 1: Actuator & Linkage Installation.....	2-1
Table 2: Troubleshooting.....	3-1
Figure 6, left, facing: F-09140 Linear Actuator wiring.	3-2
Table 3: F-09140 Linear Actuator Recommended Spare Parts.	3-3

INTENTIONALLY
BLANK

1.0 INTRODUCTION

1.1 Description of Operation

The Cleveland Controls F-09140 Linear Actuator is unsurpassed for long life, safety, reliable operation, and easy maintenance. Compact and versatile, it is suitable for any closed or open loop application. Typically it is applied as the ID fan damper actuator in draft control applications. When the F-09140 Linear Actuator is used with the Series C-07720 Draft Controller, advanced control features are available.

F-09140 Linear Actuators accept electrical line voltage signals from a switched output controller to position a final control element such as a damper, control valve, louver, stoker lever, variable speed transmission, or any similar device over a six-inch range of travel. The line voltage signals control the reversible motor in finite increments to drive an acme screw through a travel nut-and-bearing arrangement to extend or retract the drive tube. End switches shut off power to the motor when the unit reaches either travel extreme. F-09140 actuators self-lock in the event of power failure, and are not damaged by overload stalling. The inherent braking-action of the synchronous stepping motor prevents over travel without incurring the wear and stress associated with the use of "friction" or "DC" braking. All wiring connections are front accessible.

All models offer a full, six-inch range of travel. Linear or non-linear movement of the final control element, and its total range of travel, is obtained through adjustment of the linkage connecting the actuator to the operating lever arm of the final control element. All models are available in three standard stroke time or thrust configurations. The linear thrust ratings in the specifications are valid for the full, six-inch range of travel regardless of the linkage adjustment. The equivalent foot-pound ratings are provided for convenient comparison with rotary actuators.

F-09140 actuators are available with a full range of options for maximum flexibility: For applications where remote position indication is desired, an optional feedback potentiometer (135Ω, 1000Ω, or 4000Ω rated) is available. For high performance electric draft control applications, optional position switches are available to allow preset damper positioning during burner pilot ignition. An isolated auxiliary end switch can also be provided to prove full-open damper on sequencing applications where the draft control system is interfacing with a burner management system.

1.2 Specifications

PHYSICAL

Power Requirements: 120V AC or 240V AC, 50/60 Hz.

Case Dimensions: 15.75" long x 7.5" wide x 5.75" high.

Mounting: Any position.

Motor: Commercially available 72 RPM stepping motor operated in synchronous mode.

Input Signal: Switched line voltage input.

Wiring Connections: Screw-type terminals for power to motor and for all alarm and control connections.

Ambient Temperature: 0 to 140F (-19 to 60C).

Case Material: Hinged, dust-tight and drip-proof; NEMA 3 units are gasketed as required.

Finish: Wear-resistant sealed black polyurethane enamel.

Shipping Weight: 35 lbs.

APPLICATION

Travel: 6" linear travel.

Stroke Time: 30, 60, or 120 seconds per 6" of travel at 60 Hz.

Thrust: 75, 150, or 300 lbs. (Equivalent to 18.75, 37.5, and 75 foot-pounds with a 3" lever arm.)

Positioning Accuracy: +/- 0.25%.

End Switches: High and low end limit snap switches are standard. Adjustable "Safe Start" position switches or an isolated auxiliary end of travel switch are optional.

Handwheel: Continuous rotation type; optional.

Feedback Potentiometer: Optional. 1000Ω, 4000Ω and 135Ω available.

PERFORMANCE

Resolution:

- 30-second speed: 0.50% of full stroke.
- 60-second speed: 0.25% of full stroke.
- 120-second speed: 0.12% of full stroke.

Deadband: <0.2% of full stroke.

Radial Load Limit: Linkage axis not to exceed 15° deflection from drive tube axis.

Expected Service Life: 15 years at 70% duty cycle and 70% rated load.

SPECIFICATIONS ARE SUBJECT TO CHANGE WITHOUT NOTICE.

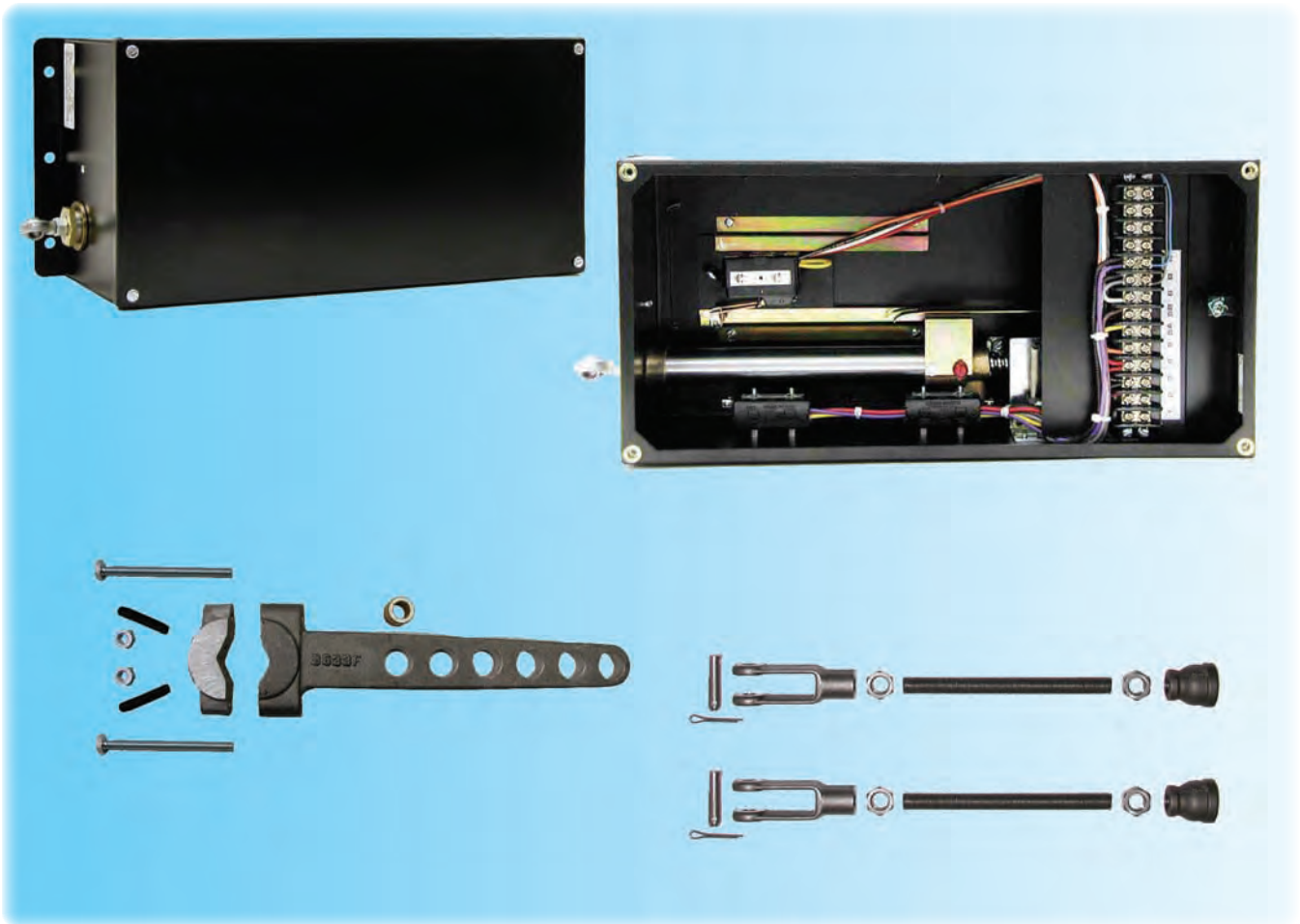

Photographs 1 & 2, top: Hays Cleveland Series F-09140 Linear Actuators are often used in draft control applications. When a Hays Cleveland Series C-07720 Sequencing Draft Control System is used with a model F-09140 Linear Actuator, adjustable starting draft positioning and other advanced options are available. See C-07720 literature for more information.

Photograph 3, bottom: A typical set of linkage for the F-09140 Actuator is shown below, consisting of (qty. 1) P/N 11372 Damper Lever Arm assembly and (qty. 2) P/N 26908 Clevis assemblies. These items are ordered separately.

1.3 Nomenclature

F-0914	—	—	—	—	—	—
	A	B	C	D	E	F

Nominal Stroke Time/ Thrust Range:

A=1 30 seconds/75 lbs. thrust (18.75 ft. lbs.)

A=2 60 seconds/150 lbs. thrust (37.5 ft. lbs.)

A=3 120 seconds/300 lbs. thrust (75.0 ft. lbs.)

Position Feedback Potentiometer:

B=0 None.

B=1 1000Ω

B=2 4000Ω

B=3 135Ω

Custom Positioning Options:

C=0 None.

C=1 Adjustable Start Position Switches.

C=2 Isolated Auxiliary End of Travel Switch.

Custom Housing Options

D=0 None.

D=1 Handwheel (Continuous Rotation Type).

D=2 NEMA 3 Rated (Weather-Resistant).

Power Requirements:

E=1 120 v AC 50/60 Hz.

E=2 240 v AC 50/60 Hz.

F=A Current Model Designation.

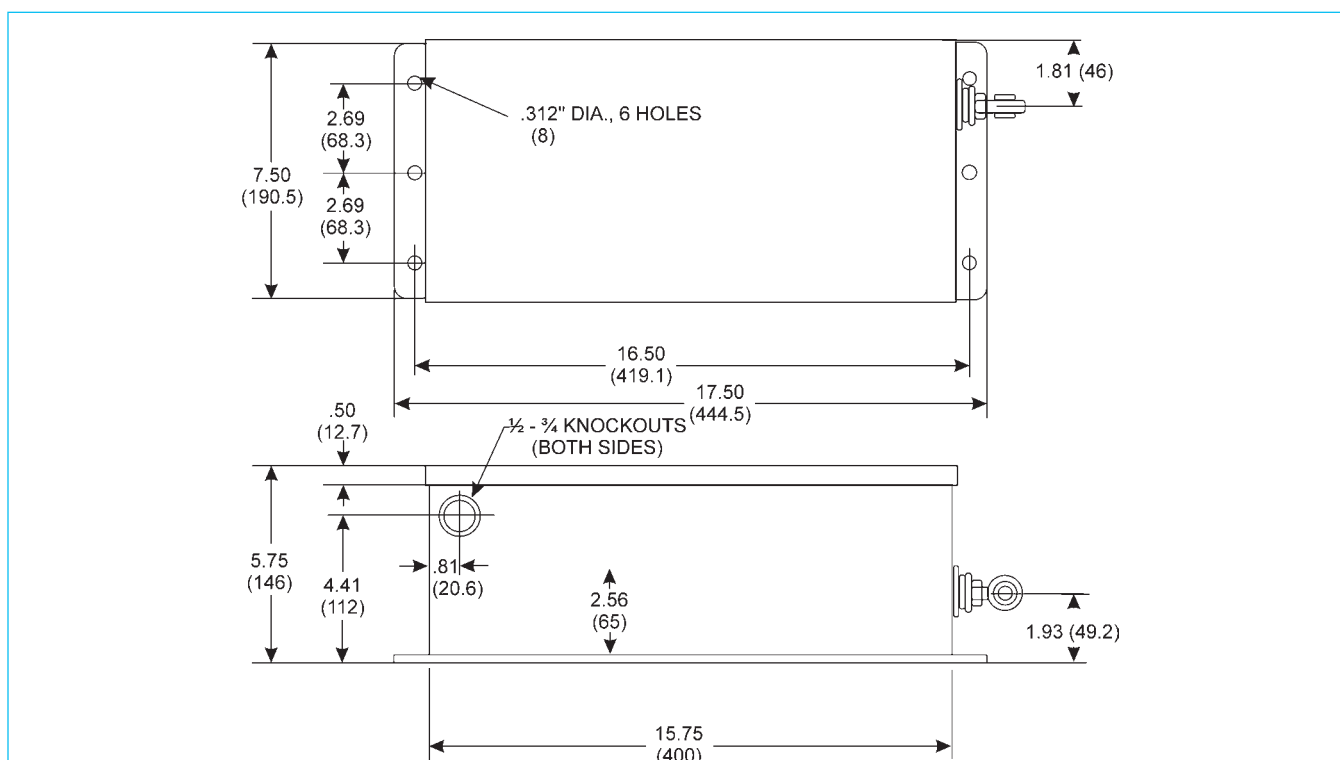

Figure 1: F-09140 Linear Actuator Linkage Dimensions.



2.0 INSTALLATION



2.1 Mounting

Mount the actuator on a flat, rigid surface that allows convenient linkage to the damper. We recommend a location where ambient temperatures are normal. The actuator should be protected from radiant or conducted heat.

2.2 Wiring

Important: Read the wiring tips on page iv of this manual.

For installation and wiring of a draft control system including a Series F-09140 Linear Actuator, see also Manual C-07720 Draft Control System.

In this manual, see Figure 3 Wiring Diagram.

2.3 Actuator Linkage (Connection to Outlet Damper)

Linkage for connecting the actuator to the outlet damper consists of the following: adjustable lever arm, two clevis assemblies, and a length of ½" pipe (furnished by the customer). For best results, the damper should be tight fitting, but with enough clearance to move freely in the breeching. On oil or gas-fired boilers, a damper seal-stop is recommended to ensure full closure when the burner shuts off. Where a standing pilot is used, the damper should be kept slightly open during the "off" periods.

A length of ½" pipe (supplied by others) is required to complete the linkage. It should never be shorter than 12" in length. For the most effective thrust, make the linkage as long as practical and position the actuator so that movement of the thrust bar is as aligned as accurately as possible with the movement of the linkage.

Actuator & Linkage Installation

1. Place the damper in the fully closed position.
2. Attach the lever arm to the damper shaft at a 45° angle to the damper (refer to **Figure 2** for vertical actuator installation or horizontal actuator installation options).
3. Insert the bronze bushing (furnished with the lever arm) in one of the holes in the lever arm. For full 6" travel, use the third hole from the rounded end.
4. Attach one clevis to the lever arm with the pin through the bushing.
5. Attach the other clevis to the actuator, with the pin through the eye in the thrust bar. The thrust bar should be fully retracted if the damper opens on the outward stroke, and fully extended if the damper opens on the inward stroke.
6. Adjust the clevis assembly until about 1" of the threaded rod extends through the adaptors.
7. Install the proper length of ½" pipe between the adaptors to complete the linkage.
8. Before operating the damper electrically with the actuator, disconnect the clevis at the actuator end by removing the pin. Operate the actuator electrically through the full cycle of travel while holding the clevis in simulated connected position and moving it to operate the damper manually. Make sure that the linkage moves freely, without restriction or binding, and that the damper moves to the maximum open and closed positions required by the particular application.
9. Reconnect the linkage and operate the damper electrically. Operating adjustments to the actuator can be made at this time, if necessary.

Table 1: Actuator & Linkage Installation

APPROXIMATE DEGREES OF DAMPER OPENING FOR EACH OF SIX HOLES IN DAMPER LEVER ARM FOR 6" STROKE OF THRUST ARM.

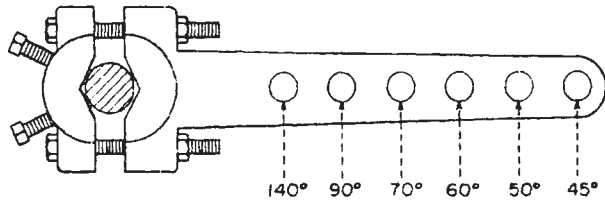

ACTUAL OPENING DEPENDS ON ANGLE OF THRUST AND DAMPER SHAFT DIAMETER.

DAMPER TRAVEL ADJUSTMENTS

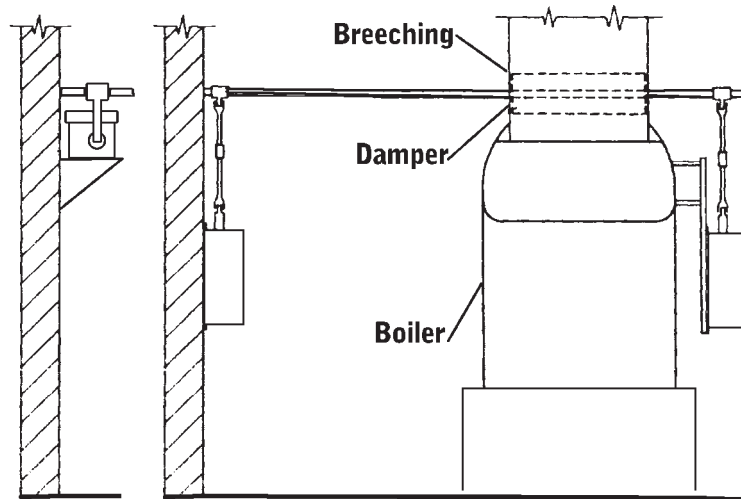
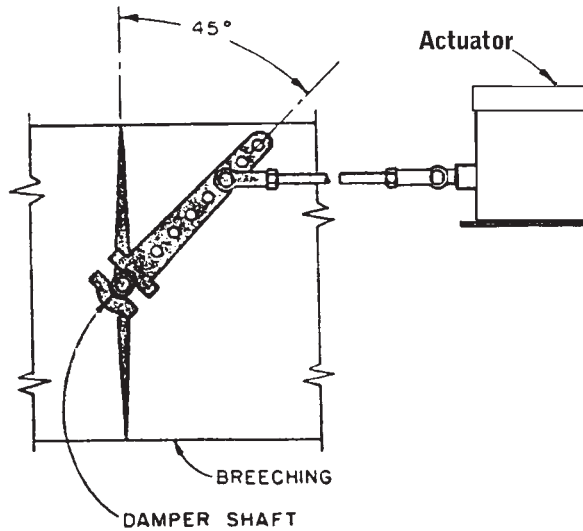
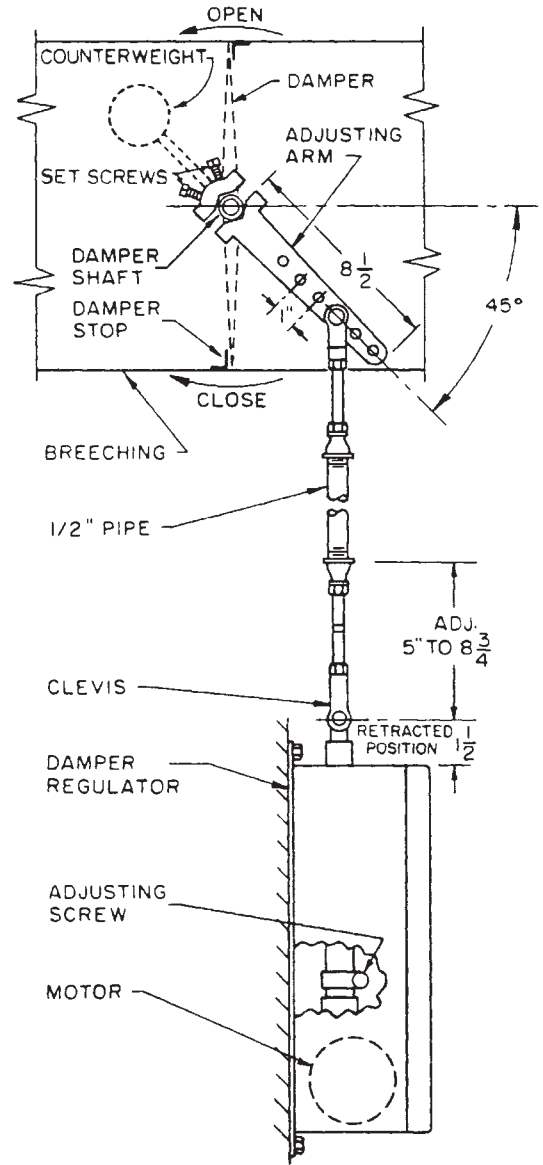

Suggested Actuator Locations

3.0 OPERATION & MAINTENANCE

3.1 Operating Tips

Hunting may occur when the damper is modulating around a nearly closed damper position. In this situation, small movements of the actuator are extremely effective. Correct the problem by moving the clevis at its lever arm end to a hole farther from the shaft. This means a sacrifice of wide-open damper: thus, to complete the procedure, readjust the linkage for the closed damper position.

For **adjustable starting position** adjustment, if this feature is used, see instructions furnished with the C-07720 Sequencing Draft Control System (C-07720 Draft Control System Instruction Manual).

3.2 Troubleshooting

Problem	Possible Source	Remedy
Drive arm hunts continuously.	Linkage is connected too close to damper shaft.	Lengthen the damper lever arm.
	Faulty control response.	Check operation of draft controller, per instructions shipped with it.
	Damper modulates at partially closed position.	See adjustment tips, above, in this manual.
Motor Overheats.	Incorrect voltage.	Check voltage.
	Incorrect wiring.	See wiring instructions with draft controller.
	High ambient temperature.	Check location and spacing; shield the unit from reflected heat.
	Overloading.	Ease load or counterbalance.
	Binding damper or linkage.	Free damper or linkage; see Table 1.
Actuator fails to operate.	Hunting.	Correct hunting, as discussed above.
	Faulty control response.	Check voltage.
	Faulty limit switches.	Check switches, replace if necessary.
	Broken belt.	Replace in field.
	Motor Failure.	Replace in field.

Table 2: Troubleshooting.

If the problem remains after trying these methods, please call the Hays Cleveland Sales Office (see Section 4.0 Customer Service). For all maintenance and repair, use only genuine Hays Cleveland replacement parts (listed below) and authorized service. If factory repair service is needed, please follow the procedure detailed in Section 4.0 Customer Service.

Facing Page:

Figure 2, top left: Damper travel adjustments.

Figure 3, top right: Typical vertical linkage arrangement.

Figure 4, center left: Typical horizontal linkage arrangement.

Figure 5, bottom: Suggested actuator locations.

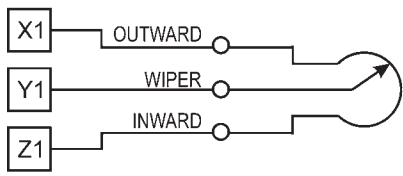
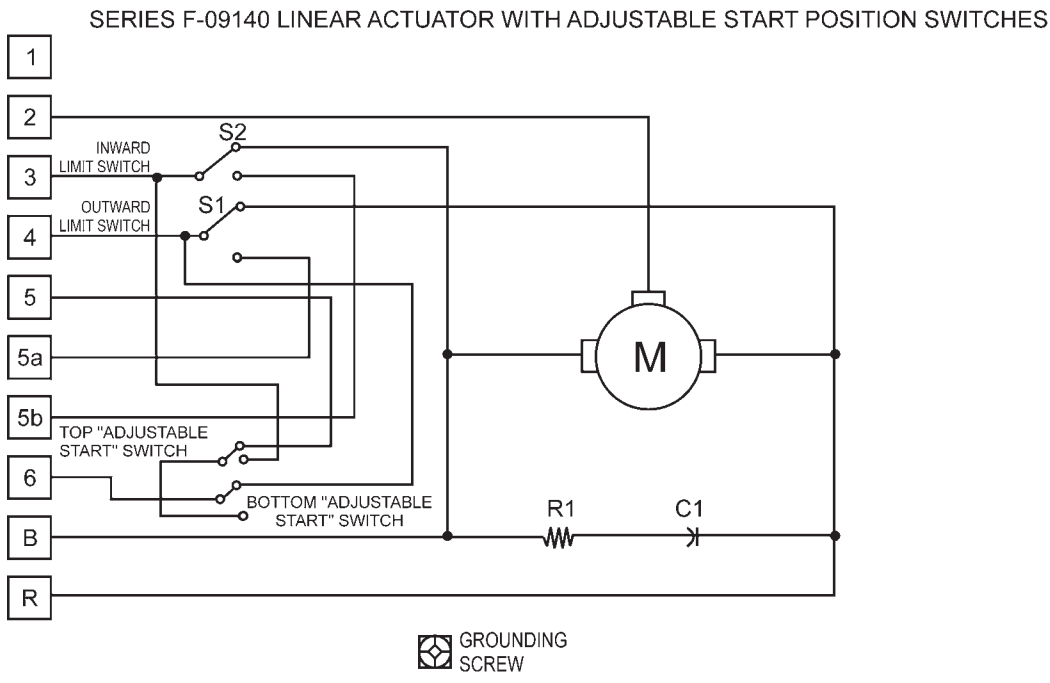
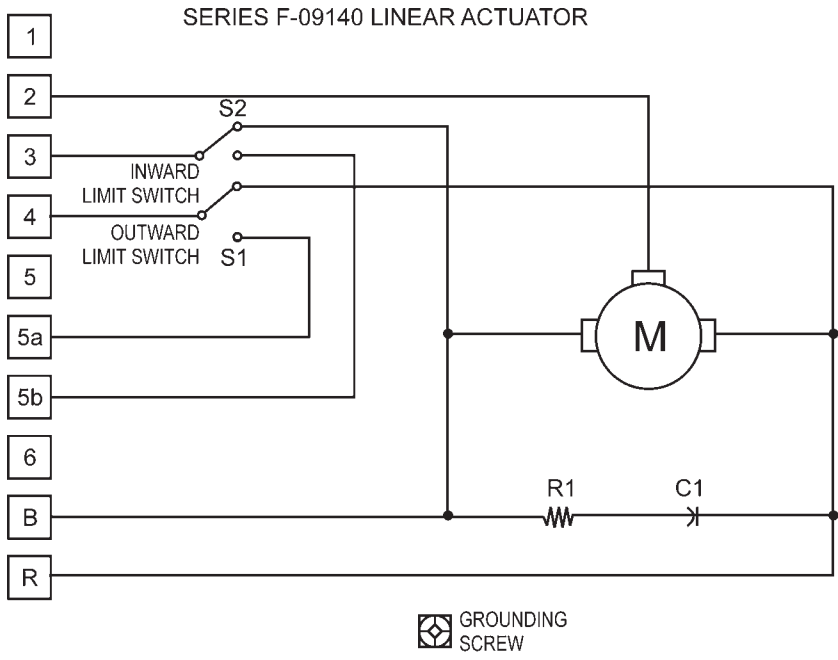

Feedback Potentiometer (Optional)

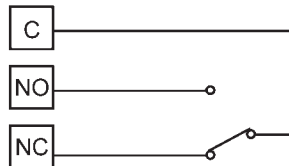

Isolated Auxiliary End of Travel Switch (Optional)

NOTES:

1. When outward stroke opens the damper, jumper terminals 5 and 5a.
2. When inward stroke opens the damper, jumper terminals 5 and 5b.
3. To reverse operation, interchange external wires to terminals 3 & 4 and (if used) X1 & Z1.
4. External wiring: Use wire suitable for 167F (75C).
5. Input rating: 120 Vac, 60 Hz., 25 VA max.

3.3.Spare Parts

Part Number	Description
11372	Damper Lever Arm Kit
26908	Clevis Assembly Kit
12677	Spring link
29060	Drive Conversion Kit (30-Sec.)
29059	Drive Conversion Kit (60-Sec.)
10467	Eyebolt assembly (Uniball Bearing)
28035-008	Motor, 120VAC
20594	Drive Belt, 60-sec./150#, 120-sec./300#
24496	Drive Belt, 30-sec./75#
28030	Motor Pulley, 60-sec./150#, 120-sec./300#
28031	Motor Pulley, 30-sec./75#
28018	Drive Screw Pulley, 60-sec./150#, 120-sec./300#
28032	Drive Screw Pulley, 30-sec./75#
31251	120VAC Resistor & Capacitor Assy.
29561	Drive Screw assembly, 30 & 60-second stroke.
29562	Drive Screw assembly, 120-second stroke.

Table 3: F-09140 Linear Actuator Recommended Spare Parts.

Figure 6, left, facing: F-09140 Linear Actuator wiring.

INTENTIONALLY
BLANK

4.0 CUSTOMER SERVICE INFORMATION

4.1 Contacts

Hays Cleveland Sales Office
 1903 South Congress Avenue
 Boynton Beach FL 33426
 Telephone: 561.734.9400
 Fax: 561.734.8060
 email: salescombustion@unicontrolinc.com

Hays Cleveland Customer Service Department
 1111 Brookpark Road
 Cleveland OH 44109
 Telephone: 216.398.4414
 Fax: 216.398.8558
 email: customerservice@unicontrolinc.com

Visit us on the WEB! <http://www.hayscleveland.com>

4.2 Repairs

Damaged or defective units may be returned to the factory for repair. However, factory authorization must be obtained before shipping whether warranty or non-warranty service is required, and all units must be shipped prepaid.

A letter of transmittal that includes the following information should accompany the returned instrument:

1. Location, type of service, and length of time in service of the unit.
2. Description of the faulty operation of the device and the circumstances of the failure.
3. Name and telephone number of the person to contact if there are questions about the unit.
4. Indicate whether warranty or non-warranty service is requested.
5. Attach Purchase Order for all out-of-warranty repairs.
6. Complete shipping instructions for the return of the repaired instrument.
7. Original purchase order number and date of purchase.
8. Return Goods Authorization number provided by the factory when you called.
9. Clearly label the shipping container:

RETURN FOR REPAIR

Model _____

RG # _____

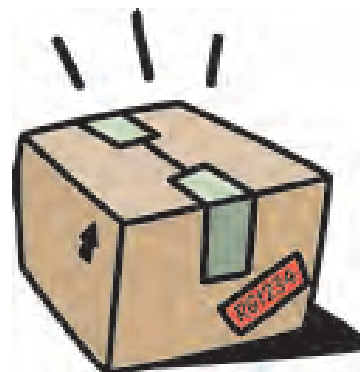

10. Ship prepaid to:

HAYS CLEVELAND
 1111 Brookpark Road
 Cleveland OH 44109-5869
 tel. 216.398.4414

Please follow this procedure. It expedites handling of the returned item, and avoids unnecessary additional charges for inspection and testing to determine the problem before repairing it.

4.3 Service

A Maintenance and Service Contract can ensure trouble-free, economical operation of Hays Cleveland equipment for many years. One-time onsite service by a factory-trained service engineer can also be provided as needed. Contact Hays Cleveland for information on these service options.

4.4 Standard Terms and Conditions of Sale

TERMS OF SALE: 1% discount if paid in ten (10) days, net amount due and payable in thirty (30) days.

AGREEMENT OF SALE: Acceptance by Seller of any order placed for goods whether submitted on Buyer's purchase order form or on seller's Sales Order Acknowledgment form, shall be subject to Seller's Standard Terms and Conditions of Sale and is conditioned upon the Buyer's acceptance of these Standard Terms and Conditions.

TERMS OF CONTRACT: Any terms or conditions of the buyer's order which are inconsistent with these terms and conditions shall not be binding on the Seller and shall not be considered applicable to the sale or shipment of goods or materials. Unless buyer shall notify Seller in writing to the contrary within ten (10) days after the mailing of the Sales Contract by Seller, acceptance of the terms and conditions hereof by Buyer shall be indicated and, in the absence of such notification, the sale and shipment by Seller of the goods and materials covered hereby shall be conclusively deemed to be subject to the terms and conditions hereof.

PRICES: All prices and specifications and applicable discounts are subject to change without notice. Sales contracts which call for delivery in the future will be billed at prices in effect at the time of shipment. Shipping weights shown are approximate and subject to change without notice.

SHIPMENT AND PAYMENTS: All prices contained on the Sales Contract are F.O.B. factory in Cleveland, Ohio. No freight is allowed on any shipments. Shipments and deliveries shall at all times be subject to the approval of Seller's Credit Department, and at any time seller may require payment in advance or satisfactory security or guarantee that invoices will be promptly paid when due. If buyer fails to comply with any terms of payment, seller, in addition to its other rights and remedies, but not in limitation thereof, reserves the right to withhold further deliveries or terminate the Agreement, and any unpaid amount thereon shall become due immediately. Terms of payment shall be as set forth on the Sales Contract.

DELAYS AND DEFAULTS: Delays or defaults in delivery by Seller of the goods and materials covered by the Sales Contract shall be excused so far as the same is caused by fire, strikes, accident, governmental regulation, or any delays unavoidable or beyond reasonable control of Seller. In no event shall Seller be liable for any consequential, special, or contingent damages on account of any default or delay in delivery.

NON-CANCELLATION: Orders are not subject to suspension, reduction, or cancellation, except on terms that will indemnify Seller against loss.

SPECIFICATIONS: Seller relies on specifications and other data furnished by the Buyer, an architect, contractor, or consulting engineer in all phases of the work covered by the Sales Contract. Seller shall be responsible to check quantities only. Alterations to or changes in specifications, approval of samples, changes in delivery instructions and all other instructions must be submitted in writing to Seller.

In the event Seller performs design or engineering work at the request of Buyer, an architect, contractor, consulting engineer, or representative in any phase of the work covered by the Sales Contract, Seller shall not be responsible for any damages claimed by Buyer as a result of alleged errors or defects in such design or engineering work.

WARRANTY AND LIMITATION OF LIABILITY: Seller warrants that the goods supplied by it have been manufactured in accordance with its standard manufacturing practices and conform to the contract or catalog description set forth in the order. Seller further warrants that the goods supplied by it are fit for the ordinary purpose or purposes specified in its catalog for which such goods are used when installed in accordance with Seller's recommended installation procedures. Except as stated herein, Seller makes no express warranty with respect to goods supplied by it and Seller makes no warranty that the goods are fit for any particular purpose.

When the use of materials not manufactured by Seller is suggested by Seller's recommended installation procedures or otherwise, Seller makes no express warranty with respect to such materials nor that such materials are merchantable or fit for any particular purpose.

Seller will, at its sole option, credit, repair or replace, any goods supplied by it which its examination shall disclose to its satisfaction are defective in workmanship or material and are returned to it within one year from the date of shipment and any claim not made within this period shall conclusively be deemed waived by Buyer. Credit, repair or replacement will be preconditioned upon examination of the goods by Seller, and, if requested by Seller, return of the goods to Seller at its direction and expense. No goods are to be returned to Seller without its written consent. Seller shall not be liable for any expense incurred by Buyer in order to remedy any defect in its goods. Seller shall not be liable for any consequential, special, or contingent damage or expense, arising directly or indirectly from any defect in its goods or from the use of any defective goods. The remedies set forth herein shall constitute the exclusive remedies available to Buyer and are in lieu of all other remedies.

CLAIMS: Claims for shortage of goods or for mistakes or errors in billing must be presented within forty-five (45) days from the date of shipment of goods and must state the packing slip number and container number applicable to the claim. Any claim not so presented will be conclusively deemed waived.

TAXES: Any federal taxes or other government charges on the sale, shipment, or installation of the goods or equipment covered by the Sales Contract shall be added to the price and paid by Buyer, or, in lieu thereof, the Buyer shall furnish the Seller with tax-exemption certificates acceptable to the taxing authority. The procedure also applies to duty and other similar charges on export sales. Seller is not responsible for sales and/or use tax in any state other than Ohio. The purchase made under this Sales Contract must be exempt or paid directly by Buyer. If Seller is required to pay any such tax, there shall be added to the prices quoted herein all such state and local taxes. Buyer agrees to reimburse and save Seller harmless from all such state and local taxes, including interest and penalties thereon, which may at any time be payable to any state or local government unit with respect to the sale of any goods or materials covered by the Sales Contract.

CORRECTIONS: Typographical or clerical errors contained in the Sales Contract, including prices, are subject to correction by the Seller.

FAIR LABOR STANDARDS: All goods covered by the Sales Contract have been produced in conformity with all applicable provisions of the Fair Labor Standards Act of 1938 as amended.

RENEGOTIATION: Unless advised by Buyer in writing, Seller assumes that Buyer's order and the Sales Contract are not renegotiable under the Renegotiation Act of 1951.

APPLICABLE LAW: All questions arising out of the Sales Contract, which shall be deemed an Ohio contract, shall be governed by the laws of the state of Ohio.

EXCLUSIVE TERMS: The Sales Contract shall constitute the complete contract between the parties, and no one has authority to depart from the terms and conditions set forth therein, nor to make any representations or arrangements other than those printed thereon whether in the execution or in the performance of the Sales Contract, unless the same are written on the face of the Sales Contract or are given in writing with it or in pursuance of it, and are fully approved in writing by an officer or authorized employee of the Seller.

LIMITATION FOR SUITS: Any controversy or claim arising out of or relating to this Sales Contract or the breach thereof, must be commenced within one (1) year after the cause of action accrued.
